

Arm® Debug Interface Architecture Specification

ADIV6.0

arm

Arm Debug Interface Architecture Specification

ADiv6.0

Copyright © 2017, 2018, 2020, 2022, 2024 Arm Limited or its affiliates. All rights reserved.

Release Information

The following changes have been made to this book.

Change History

Date	Issue	Confidentiality	Change
9 March 2017	A	Non-Confidential	First issue, for ADiv6.
30 April 2018	B	Non-Confidential	Second issue, for ADiv6.
24 July 2020	C	Non-Confidential	Third issue, for ADiv6.
25 February 2022	D	Non-Confidential	Fourth issue, for ADiv6.
24 July, 2024	E	Non-Confidential	Fifth issue, for ADiv6.

Proprietary Notice

This document is protected by copyright and other related rights and the use or implementation of the information contained in this document may be protected by one or more patents or pending patent applications. No part of this document may be reproduced in any form by any means without the express prior written permission of Arm Limited (“Arm”). **No license, express or implied, by estoppel or otherwise to any intellectual property rights is granted by this document unless specifically stated.**

Your access to the information in this document is conditional upon your acceptance that you will not use or permit others to use the information for the purposes of determining whether the subject matter of this document infringes any third party patents.

The content of this document is informational only. Any solutions presented herein are subject to changing conditions, information, scope, and data. This document was produced using reasonable efforts based on information available as of the date of issue of this document. The scope of information in this document may exceed that which Arm is required to provide, and such additional information is merely intended to further assist the recipient and does not represent Arm's view of the scope of its obligations. You acknowledge and agree that you possess the necessary expertise in system security and functional safety and that you shall be solely responsible for compliance with all legal, regulatory, safety and security related requirements concerning your products, notwithstanding any information or support that may be provided by Arm herein. In addition, you are responsible for any applications which are used in conjunction with any Arm technology described in this document, and to minimize risks, adequate design and operating safeguards should be provided for by you.

This document may include technical inaccuracies or typographical errors. THIS DOCUMENT IS PROVIDED “AS IS”. ARM PROVIDES NO REPRESENTATIONS AND NO WARRANTIES, EXPRESS, IMPLIED OR STATUTORY, INCLUDING, WITHOUT LIMITATION, THE IMPLIED WARRANTIES OF MERCHANTABILITY, SATISFACTORY QUALITY, NON-INFRINGEMENT OR FITNESS FOR A PARTICULAR PURPOSE WITH RESPECT TO THE DOCUMENT. For the avoidance of doubt, Arm makes no representation with respect to, and has undertaken no analysis to identify or understand the scope and content of, any patents, copyrights, trade secrets, trademarks, or other rights.

TO THE EXTENT NOT PROHIBITED BY LAW, IN NO EVENT WILL ARM BE LIABLE FOR ANY DAMAGES, INCLUDING WITHOUT LIMITATION ANY DIRECT, INDIRECT, SPECIAL, INCIDENTAL, PUNITIVE, OR CONSEQUENTIAL DAMAGES, HOWEVER CAUSED AND REGARDLESS OF THE THEORY OF LIABILITY, ARISING OUT OF ANY USE OF THIS DOCUMENT, EVEN IF ARM HAS BEEN ADVISED OF THE POSSIBILITY OF SUCH DAMAGES.

Reference by Arm to any third party's products or services within this document is not an express or implied approval or endorsement of the use thereof.

This document consists solely of commercial items. You shall be responsible for ensuring that any permitted use, duplication or disclosure of this document complies fully with any relevant export laws and regulations to assure that this document or any portion thereof is not exported, directly or indirectly, in violation of such export laws. Use of the word “partner” in reference to Arm’s customers is not intended to create or refer to any partnership relationship with any other company. Arm may make changes to this document at any time and without notice

This document may be translated into other languages for convenience, and you agree that if there is any conflict between the English version of this document and any translation, the terms of the English version of this document shall prevail.

The validity, construction and performance of this notice shall be governed by English Law.

The Arm corporate logo and words marked with ® or ™ are registered trademarks or trademarks of Arm Limited (or its affiliates) in the US and/or elsewhere. Please follow Arm's trademark usage guidelines at <https://www.arm.com/company/policies/trademarks>. All rights reserved. Other brands and names mentioned in this document may be the trademarks of their respective owners.

Copyright © 2017, 2018, 2020, 2022, 2024 Arm Limited or its affiliates. All rights reserved.

Arm Limited. Company 02557590 registered in England.

110 Fulbourn Road, Cambridge, England CB1 9NJ.

PRE-20349

8 March 2024

Confidentiality Status

This document is Non-Confidential. Any use by you is subject to the terms of the agreement between you and Arm or the terms of the agreement between you and the party authorized by Arm to disclose this document to you.

Product Status

The information in this document is final, that is for a developed product.

Web Address

<http://www.arm.com>

Contents

Arm Debug Interface Architecture Specification

ADIV6.0

Preface

About this manual	X
Using this book	xi
Conventions	xiii
Additional reading	xv
Feedback	xvi

Part A The Arm Debug Interface

Chapter A1

About the Arm Debug Interface

A1.1	ADI versions	A1-20
A1.2	Purpose of the ADI	A1-21
A1.3	The debug link	A1-23
A1.4	The subdivisions of an ADIV6 implementation	A1-25
A1.5	The Debug Port (DP)	A1-27
A1.6	Access Ports (APs)	A1-28
A1.7	Design choices and implementation examples	A1-32
A1.8	Power Requests	A1-36

Part B The Debug Port

Chapter B1

About the DP

B1.1	MINDP, Minimal DP extension	B1-42
B1.2	Sticky flags and DP error responses	B1-43
B1.3	The transaction counter	B1-45

B1.4	Pushed-compare and pushed-verify operations	B1-46
B1.5	Power and reset control	B1-48

Chapter B2

DP Reference Information

B2.1	DP architecture versions	B2-50
B2.2	DP register descriptions	B2-53
B2.3	System and debug power control behavior	B2-82
B2.4	Debug reset control behavior	B2-87
B2.5	System reset control behavior	B2-89

Chapter B3

The JTAG Debug Port

B3.1	About the JTAG-DP	B3-92
B3.2	The scan chain interface	B3-93
B3.3	IR scan chain and IR instructions	B3-96
B3.4	DR scan chain and DR instructions	B3-99

Chapter B4

The Serial Wire Debug Port

B4.1	About the SWD protocol	B4-114
B4.2	SWD protocol operation	B4-118
B4.3	SWD interface	B4-130

Chapter B5

The Serial Wire/JTAG Debug Port

B5.1	About the SWJ-DP	B5-134
B5.2	Switching between SWD and JTAG	B5-136
B5.3	Dormant operation	B5-139
B5.4	Restrictions on switching between operating modes	B5-146

Part C

The Access Port

Chapter C1

About the AP

C1.1	AP requirements	C1-150
C1.2	Selecting and accessing an AP	C1-151
C1.3	AP Programmers' Model Summary	C1-152
C1.4	AP Register Descriptions	C1-153

Chapter C2

The Memory Access Port

C2.1	About the MEM-AP	C2-172
C2.2	MEM-AP functions	C2-177
C2.3	Implementing a MEM-AP	C2-192
C2.4	MEM-AP examples of pushed-verify and pushed-compare	C2-196
C2.5	MEM-AP programmers' model	C2-198
C2.6	MEM-AP register descriptions	C2-201

Chapter C3

The JTAG Access Port

C3.1	About the JTAG-AP	C3-244
C3.2	Operation of the JTAG-AP	C3-249
C3.3	The JTAG Engine Byte Command Protocol	C3-252
C3.4	JTAG-AP programmers' model	C3-259
C3.5	JTAG-AP register descriptions	C3-261

Part D

ROM Tables

Chapter D1

About ROM Tables

D1.1	ROM Tables Overview	D1-290
D1.2	ROM Table Types	D1-291

D1.3	Component and Peripheral ID Registers for ROM Tables	D1-292
D1.4	The component address	D1-293
D1.5	Location of the ROM Table	D1-294
D1.6	ROM Table hierarchies	D1-295

Chapter D2

Class 0x1 ROM Tables

D2.1	About Class 0x1 ROM Tables	D2-300
D2.2	Class 0x1 ROM Table summary	D2-301
D2.3	Use of power domain IDs	D2-303
D2.4	Register Descriptions	D2-305

Chapter D3

Class 0x9 ROM Tables

D3.1	About Class 0x9 ROM Tables	D3-314
D3.2	Class 0x9 ROM Table summary	D3-315
D3.3	Use of power domain IDs	D3-319
D3.4	Reset control	D3-325
D3.5	Register descriptions	D3-328

Part E

Appendixes

Appendix E1

Standard Memory Access Port Definitions

E1.1	Introduction	E1-360
E1.2	AMBA AXI3 and AXI4	E1-361
E1.3	AMBA AXI4 with ACE-Lite	E1-363
E1.4	AMBA AXI5	E1-366
E1.5	AMBA AHB3	E1-370
E1.6	AMBA AHB5	E1-373
E1.7	AMBA AHB5 with enhanced HPROT control	E1-375
E1.8	AMBA APB2 and APB3	E1-377
E1.9	AMBA APB4 and APB5	E1-378

Appendix E2

Cross-over with the Arm Architecture

E2.1	Introduction	E2-382
E2.2	Armv6-M, Armv7-M, and Armv8-M architecture profiles	E2-383
E2.3	PEs with a physical address up to 32 bits	E2-384
E2.4	PEs with a physical address greater than 32 bits	E2-385
E2.5	Summary of the requirements for ADIv6 implementations	E2-386

Appendix E3

Revisions

Glossary

Preface

This preface introduces the *Arm Debug Interface Architecture Specification ADIv6.0*. It contains the following sections:

- *About this manual* on page x.
- *Using this book* on page xi.
- *Conventions* on page xiii.
- *Additional reading* on page xv.
- *Feedback* on page xvi.

About this manual

This manual describes the *Arm Debug Interface Architecture Specification ADIV6.0* (ADIV6).

Intended audience

This specification is written for system designers and engineers who specify, design, or implement ADIV6-compliant debug interfaces. The audience includes system designers and engineers who specify, design, or implement a *System-on-Chip* (SoC) that incorporates an ADIV6-compliant debug interface.

This specification is also intended for engineers who are working with a debug interface that conforms to the ADIV6 specification. This audience includes designers and engineers who:

- Specify, design, or implement hardware debuggers.
- Specify, design, or write debug software.

These engineers have no control over the design decisions that are made in the ADIV6 interface implementation to which they connect but must be able to identify the ADIV6 interface components that are present, and understand how they operate.

This specification provides an architectural description of an ADIV6 interface. It does not describe how to implement the interface.

Using this book

This specification is organized into the following chapters:

Chapter A1 *About the Arm Debug Interface*

Read this chapter for a high-level view of the *Arm Debug Interface* (ADI). This chapter defines the logical subdivisions of an ADI, and summarizes the design choices that are made when implementing an ADI.

Chapter B1 *About the DP*

Every ADI includes a single *Debug Port* (DP). The DP can be one of several types: a *JTAG Debug Port* (JTAG-DP), a *Serial Wire Debug Port* (SW-DP), or a *Serial Wire/JTAG Debug Port* (SWJ-DP). Read this chapter for a description of the features that must be implemented on the DP of any ADI.

Chapter B2 *DP Reference Information*

Read this chapter for detailed reference information that applies to all DP types.

Chapter B3 *The JTAG Debug Port*

Read this chapter for a description of the JTAG-DP, and in particular, the *Debug Test Access Port State Machine* (DBGTAPSM) and the scan chains that access the JTAG-DP.

Chapter B4 *The Serial Wire Debug Port*

Read this chapter for a description of the SW-DP and the *Serial Wire Debug* (SWD) protocols, that are used to access an SW-DP.

Chapter B5 *The Serial Wire/JTAG Debug Port*

Read this chapter for a description of multiple protocol interoperability as implemented in the SWJ-DP CoreSight component.

Chapter C1 *About the AP*

Read this chapter for a description of ADI *Access Ports* (APs), and details of the features that every AP must implement.

Chapter C2 *The Memory Access Port*

Read this chapter for a description of the ADI *Memory Access Port* (MEM-AP).

Chapter C3 *The JTAG Access Port*

Read this chapter for a description of the ADI *JTAG Access Port* (JTAG-AP).

Chapter D1 *About ROM Tables*

Read this chapter for a general description of Arm debug component ROM Tables. Any ADI can include a ROM Table, and an ADI with more than one debug component must include at least one ROM Table.

Chapter D2 *Class 0x1 ROM Tables*

Read this chapter for detailed information about Class 0x1 ROM Tables. Class 0x1 ROM Tables have a Component class value of 0x1.

Chapter D3 *Class 0x9 ROM Tables*

Read this chapter for detailed information about Class 0x9 ROM Tables. Class 0x9 ROM Tables have a Component class value of 0x9, which identifies them as CoreSight components. A value of the Component Architecture ID of 0x0AF7 identifies the component as a Class 0x9 ROM Table.

Appendix E1 *Standard Memory Access Port Definitions*

Read this appendix for information on implementing the *Memory Access Port* (MEM-AP).

Appendix E2 *Cross-over with the Arm Architecture*

Read this appendix for a description of the required or recommended options for the ADI for Arm architecture profiles.

Appendix E3 *Revisions*

Read this appendix for information on the changes between issues of this document.

Glossary

Read the Glossary for definitions of some of the terms that are used in this manual.

Conventions

The following sections describe conventions that this specification can use:

- [Typographic conventions](#).
- [Signals](#).
- [Timing diagrams](#).
- [Numbers on page xiv](#).
- [Pseudocode descriptions on page xiv](#).

Typographic conventions

The typographical conventions are:

italic Introduces special terminology, and denotes citations.

bold Denotes signal names, and is used for terms in descriptive lists, where appropriate.

`monospace` Used for assembler syntax descriptions, pseudocode, and source code examples.
Also used in the main text for instruction mnemonics and for references to other items appearing in assembler syntax descriptions, pseudocode, and source code examples.

SMALL CAPITALS

Used for a few terms that have specific technical meanings, and are included in the [Glossary](#).

Colored text Indicates a link:

- A URL, for example <https://developer.arm.com>.
- A cross-reference, that, if it is not on the current page, includes the page number of the referenced information. For example, [Pseudocode descriptions on page xiv](#).
- A link, to a chapter or appendix, or to a glossary entry, or to the section of the document that defines the colored term, for example [AMBA](#).

Signals

The signal conventions are:

Signal level The level of an asserted signal depends on whether the signal is active-HIGH or active-LOW. Asserted means:

- HIGH for active-HIGH signals.
- LOW for active-LOW signals.

Lower-case n At the start or end of a signal name denotes an active-LOW signal.

Prefix DBG Denotes debug signals.

Timing diagrams

The figure that is named [Key to timing diagram conventions on page xiv](#) explains the components that are used in timing diagrams. Variations, when they occur, have clear labels. Do not assume any timing information that is not explicit in the diagrams.

Shaded bus and signal areas are undefined, so the bus or signal can assume any value within the shaded area at that time. The actual level is unimportant and does not affect normal operation.

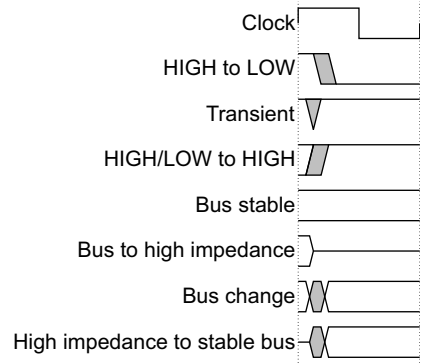

Key to timing diagram conventions

Timing diagrams sometimes show single-bit signals as HIGH and LOW at the same time and they look similar to the bus change shown in *Key to timing diagram conventions*. If a timing diagram shows a single-bit signal in this way, its value does not affect the accompanying description.

Numbers

Numbers are normally written in decimal. Binary numbers are preceded by `0b`, and hexadecimal numbers by `0x`. In both cases, the prefix and the associated value are written in a monospace font, for example `0xFFFF0000`.

Pseudocode descriptions

This specification uses a form of pseudocode to provide precise descriptions of the specified functionality. This pseudocode is written in a monospace font, and is described in *Chapter J1, Armv8 Pseudocode* of the *Arm® Architecture Reference Manual, for A-profile architecture*.

Additional reading

This section lists relevant publications from Arm and third parties.

See Arm Developer <https://developer.arm.com>, for access to Arm documentation.

Arm publications

See the following documents for other information that is relevant to this specification:

- *Arm® Architecture Reference Manual, for A-profile architecture* (ARM DDI 0487).
- *Arm® Architecture Reference Manual, Armv7-A and Armv7-R edition* (ARM DDI 0406).
- *Arm® Realm Management Extension (RME) System Architecture* (ARM DEN 0129).
- *Arm® Architecture Reference Manual Supplement, the Realm Management Extension (RME), for Armv9-A* (ARM DDI 0615).
- *Arm® v8-M Architecture Reference Manual* (ARM DDI 0553).
- *Arm® Embedded Trace Macrocell Architecture Specification, ETMv4* (ARM IHI 0064).
- *ARM® Debug and Trace Configuration and Usage Models* (ARM DEN 0034A).
- *Arm® CoreSight™ Architecture Specification* (ARM IHI 0029).
- *Arm® CoreSight™ SoC-400 Technical Reference Manual* (ARM 100536).
- *AMBA® AXI™ and ACE™ Protocol Specification* (ARM IHI 0022).
- *Arm® AMBA® 5 AHB™ Protocol Specification, AHB5™, AHB-Lite™* (ARM IHI 0033b).
- *AMBA® APB™ Protocol Specification* (ARM IHI 0024).
- *Arm1136JF-S™ and Arm1136J-S™ Technical Reference Manual* (ARM DDI 0211).
- *Advanced Communications Channel™ Architecture Specification* (ARM IHI 0076).

Other publications

The following books are referred to in this specification, or provide more information:

- *IEEE Standard Test Access Port and Boundary Scan Architecture* (IEEE 1149.1-2001).
- *JEDEC Standard Manufacturer's Identification Code* (JEDEC JEP106).

Feedback

Arm welcomes feedback on its documentation.

Feedback on this book

If you have comments on the content of this specification, send an e-mail to errata@arm.com. Give:

- The title.
- The number, ARM IHI 0074E.
- The page numbers to which your comments apply.
- A concise explanation of your comments.

Arm also welcomes general suggestions for additions and improvements.

———— **Note** —————

Arm tests PDFs only in Adobe Acrobat and Acrobat Reader, and cannot guarantee the appearance or behavior of any document when viewed with any other PDF reader.

Progressive terminology commitment

Arm values inclusive communities. Arm recognizes that we and our industry have used terms that can be offensive.

Arm strives to lead the industry and create change.

Previous issues of this document included terms that can be offensive. We have replaced these terms. If you find offensive terms in this document, please contact terms@arm.com.

Part A

The Arm Debug Interface

Chapter A1

About the Arm Debug Interface

This chapter introduces the *Arm Debug Interface (ADI)* architecture and summarizes the design decisions that are required for an ADI implementation. It contains the following sections:

- *ADI versions on page A1-20.*
- *Purpose of the ADI on page A1-21.*
- *The debug link on page A1-23.*
- *The subdivisions of an ADIv6 implementation on page A1-25.*
- *The Debug Port (DP) on page A1-27.*
- *Access Ports (APs) on page A1-28.*
- *Design choices and implementation examples on page A1-32.*
- *Power Requests on page A1-36.*

A1.1 ADI versions

The *Arm Debug Interface version 6* (ADIV6) is the sixth major version of the Arm Debug Interface (ADI).

———— **Note** —————

The term ADIV6 refers to any release of the sixth major revision of ADI. Because version 6.0 is the only released revision to date, in this document ADIV6 and ADIV6.0 refer to the same revision.

Debug interface versions 1 and 2

Implemented on the ARM7TDMI® and ARM9® families of processor cores.

Debug interface version 3

Introduced for the ARM10™ processor family.

ADIV4 The first version of the ADI to be linked with an Arm architecture version, rather than an implementation of an Arm processor core. Arm recommends that ADIV4 is used with implementations of the Armv6 architecture.

ADIV5 Removed the link between the ADI and Arm processor cores, and formalized version numbering of Debug Ports.

ADIV6.0 provides a layering system that allows memory-mapped access to all parts of a system from multiple different agents, including off-chip debuggers and on-chip software. Access to system resources that are not memory-mapped must be provided by abstraction layers which are memory-mapped. To control JTAG devices, for example, a memory-mapped component that is capable of interfacing with the JTAG device must be provided.

ADIV6 comprises the following layers:

- A JTAG or SWD physical layer. For more detail on the JTAG physical layer, see *IEEE Standard Test Access Port and Boundary Scan Architecture*.
- A JTAG or SWD protocol layer, for managing the JTAG and SWD state machines.
- A JTAG or SWD Data Link layer, for performing accesses to DP registers and AP registers.
- The AP layer, for access to one or more subsystems in an SoC.

ADIV6 permits debug links other than JTAG or SWD to access the AP layer, so that multiple different links can be used to access debug functionality. Such debug links can be other functional interfaces to the SoC, or on-chip debug software.

To accommodate these enhancements, ADIV6 includes the following version changes to the DP and AP:

- The new DP architecture version is DPv3. ADIV6 only permits use of DPv3.

———— **Note** —————

DPv3 is not fully backwards compatible with earlier DP versions.

- The new AP architecture version is APv2. ADIV6 only permits use of APv2 APs.

———— **Note** —————

The ADIV5 AP is referred to as APv1, to provide a distinction from the ADIV6 APv2.

A1.2 Purpose of the ADI

The ADI provides access to debug functionality that is provided by debug components in an embedded SoC.

This section summarizes various types of debug functionality that can be found in SoCs. It contains the following subsections:

- [Embedded core debug functionality](#).
- [System debug functionality](#).
- [Compatibility between CoreSight and Arm debug interfaces on page A1-22](#).

For information about compatibility with the CoreSight™ architecture, see [Compatibility between CoreSight and Arm debug interfaces on page A1-22](#).

A1.2.1 Embedded core debug functionality

An embedded microprocessor can provide the following debug features to enable the debugging of applications:

Processor state modification

Facilities that enable an external host to modify the state of the processor, as defined by the contents of the internal registers and the memory system.

Processor state assessment

Facilities that enable an external host to assess the state of the processor by providing access to the contents of the internal registers and the memory system.

Programming debug events

Facilities that allow an external host to program debug events. An external host must be able to configure the debug logic so that when a special event occurs, such as the program flow reaching a certain instruction in the code, the core enters a special execution mode in which its state can be examined and modified by an external system. In this chapter, this special execution mode is referred to as Debug state.

Enter or exit Debug state

Facilities to allow an external system to force the processor to enter or exit Debug state, and determine when the core enters or leaves Debug state.

Trace features

Trace the program flow that is associated with programmable events.

Examples of technologies that provide these facilities are:

- The Armv8 Debug Architecture. For more information, see the *Arm® Architecture Reference Manual, for A-profile architecture*.
- The ETM. For more information, see the *ETM Architecture Specification*.

ADIV6 implementations can also access legacy components that implement an IEEE 1149.1 JTAG interface, which enables accessing debug resources in processors that implement earlier versions of the ADI.

A1.2.2 System debug functionality

The scope of debug information extends beyond the boundaries of an embedded microprocessor core, and includes the following elements:

- Components outside the cores that are embedded in the SoC.
- The interconnection fabric of the system.

To enable debugging these elements, a SoC can provide the following system-level debug features:

External host access

Facilities that enable an external host to access the following debug information:

- System state parameters that might not be visible to the embedded microprocessor core.
- Trace information about the interconnection fabric, for example accesses by the microprocessor core, or accesses by other devices such as *Direct Memory Access* (DMA) engines.

Access to diagnostic information

A mechanism for the efficient collection and streaming of diagnostic information, for example program trace.

Diagnostic messaging

Mechanisms for low-intrusion diagnostic messaging between software and debugger.

Cross-triggering

Cross-triggering mechanisms that enable debug components to signal to each other.

Examples of technologies that provide these facilities are:

- A debug port that is compliant with the ADIV6 architecture.
- The CoreSight debug architecture. For more information, see the *Arm® CoreSight™ Architecture Specification*.
- CoreSight components. For more information, see the *CoreSight SoC Technical Reference Manual*.

A1.2.3 Compatibility between CoreSight and Arm debug interfaces

ADIV6 is compatible with the Arm CoreSight architecture:

- ADIV6 can be used to access and control CoreSight-compatible components.
- The ADIV6 specification does not require debug components to comply with the CoreSight architecture.

A1.3 The debug link

A basic principle of this specification is that the debug link provides a means to perform memory-mapped transactions to the AP layer. Examples of debug links include:

- JTAG/SWD, using an ADIV6 DP.
- Normal functional links, for example PCIe, USB, and IP sockets.
- On-chip software.

As a result of applying this principle, it is sufficient for the debug agent that uses the AP layer to understand how to use memory-mapped transactions.

To determine the identity and topology of the system, the debug agent needs a starting address to interrogate the system. A single address that can be up to 64 bits wide, provides the base address of the first component on the list of components to be identified. The first component is one of the following:

- A single CoreSight component that is not a ROM Table, and is the only component that is accessible via this link.
- An AP. An AP provides a bridge into another system. A MEM-AP provides a window into a memory system. A MEM-AP provides the base address of the first component on the list of components to be identified in the memory system that is accessed by the MEM-AP, and this base address must be used to continue identification.
- A ROM Table. This ROM Table contains addresses of one or more further components on the list of components to be identified.

ROM Tables are permitted to point to other ROM Tables with no limit on the depth of nesting.

MEM-APs are permitted to be accessible from other MEM-APs, although Arm strongly recommends that nesting of MEM-APs in this way is not implemented.

An example system with two memory systems is shown in [Figure A1-2 on page A1-25](#).

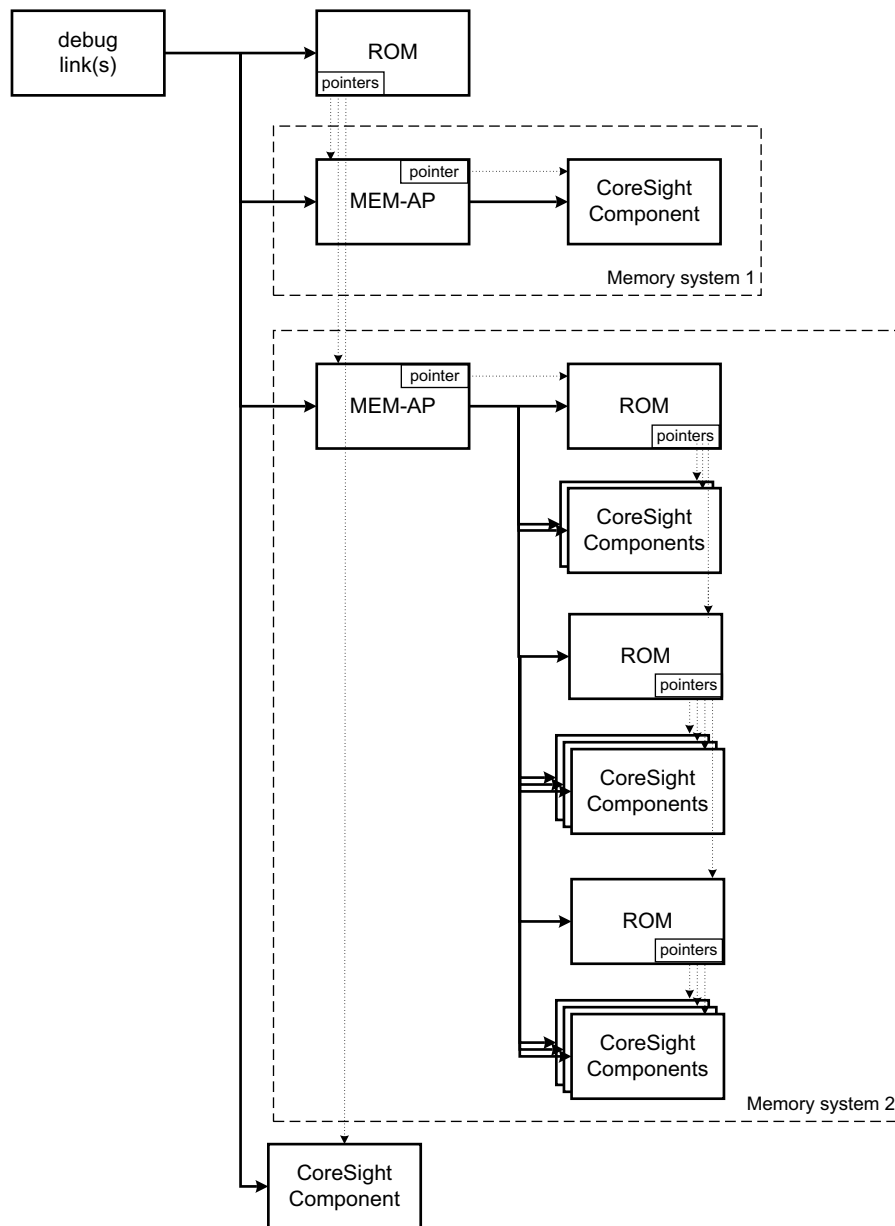

Figure A1-1 Example ADIV6 system

On-chip debug software does not always have to perform accesses via the top-most layer, and can enter at lower layers. Referring to [Figure A1-1](#), for a self-hosted debug software in a CPU in memory system 2 to access components in memory system 2, it must only use components within the memory system of the host processor. It does not need to go via the MEM-AP for that memory system, and can directly access a layer below the MEM-AP.

As shown in the example in [Figure A1-1](#), a CoreSight component might be at the top level, outside all memory systems, for example a *Trace Port Interface Unit* (TPIU) component that is shared across all memory systems and is only accessed by external debuggers.

A1.4 The subdivisions of an ADiv6 implementation

An implementation of the ADI provides a debugger with a standard interface to access debug resources in systems that use resource-specific methods to expose their debug information. An implementation of the ADI is sometimes called a *Debug Access Port* (DAP).

A1.4.1 Connections to the ADI

The logical block diagram in [Figure A1-2](#) shows how an ADI implementation is connected between a debugger and the system to be debugged.

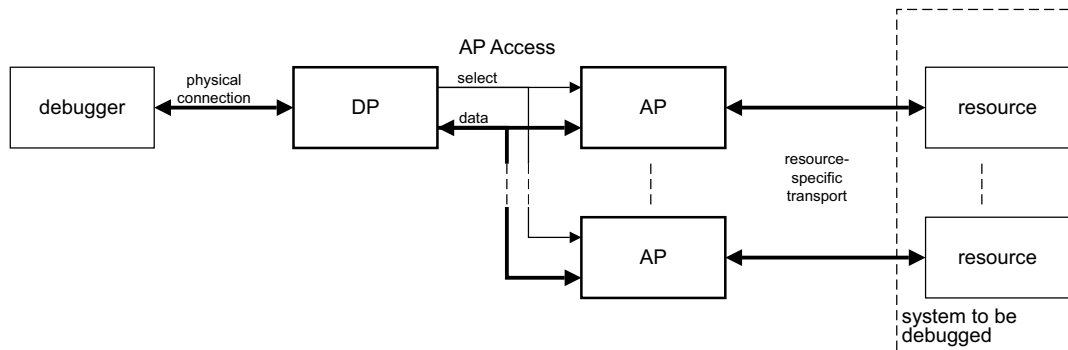

Figure A1-2 Block diagram of an ADiv6 implementation

To access a debug resource, the debugger passes the appropriate resource address information to the ADI, which executes the request by selecting the appropriate resource and then accessing resource-specific transport methods that are presented by the system to be debugged. An implementation of the ADI consists of the following elements:

Access Port (AP)

An AP uses a resource-specific transport mechanism to access debug information in the system to be debugged, and passes the information to the DP using the AP Access mechanism that is specified in this document. Examples of debug resources are:

- The debug registers of the core processor.
- ETM or trace port debug registers.
- A ROM Table, see [Chapter D1 About ROM Tables](#).
- A memory system.
- A legacy JTAG device.

A debugger uses AP accesses to exchange information held in the AP registers, as described in [Access Ports \(APs\) on page A1-28](#)

This specification is for APv2. ADiv6 only permits use of APv2 APs.

Debug Port (DP)

The DP provides a debugger with a common interface to access the information that is held in the APs. The DP includes the following elements:

- A physical connection to the debugger. ADiv6 supports the following physical connection types:
 - JTAG-DP.
 - SW-DP.
 - SWJ-DP.

For details about the supported physical connections, see [Chapter B1 About the DP](#).

- DP registers that hold information required to support the transport mechanism that is implemented by the DP, as described in [Accessing the DP and AP registers](#). A debugger uses the DPACC scan chain to exchange information held in the DP registers. For detailed information about the DP registers, see [DP register descriptions on page B2-53](#). This specification is for DPv3. ADiv6 only permits use of DPv3 DPs.

Resource-specific transport

The connection between the DP and the APs, which performs the following tasks:

- Select the appropriate debug resource, which is based on the address information that was provided by the debugger.
- Transport the data between the APs and the DP.

A1.4.2 Accessing the DP and AP registers

The diagram in [Figure A1-2 on page A1-25](#) shows how a debugger logically accesses the DP and AP registers.

- Although the DP is involved in responding to APACC requests, this involvement is transparent to the debugger at the level of the APACC.
- The debugger can use the DPACC method to access the DP registers, and achieve one of the following:
 - Set the parameters for an imminent APACC. For example, the selection of a particular AP is done by setting the DP register [SELECT on page B2-76](#).
 - Read status information for a previous APACC. For example, the status of the sticky flags resulting from previous resource accesses is available from the DP register CTRL/STAT.

For details about the communication between the debugger and the DP, see [The Debug Port \(DP\) on page A1-27](#).

———— Note —————

Although this specification defines the ADiv6 in terms of the elements that are shown in [Figure A1-2 on page A1-25](#), it is not mandatory to structure implementations in this way. The elements that are shown in the figure, however, provide a convenient representation for describing the programmers' model, which is the objective of this specification.

A1.5 The Debug Port (DP)

An ADI implementation includes a single DP that provides the following features:

- An external physical connection to the interface. The signals that make up the physical connection depends on the DP type.
- A method to obtain the identification code of the DP.
- DP and AP access methods, which depend on the DP type.
- Optionally, a method to abort a register access that appears to have failed.
- A method to determine the address size that is used by the ADI.
- A pointer that informs the debugger where to start searching for components, including ROM Tables and APs.

The ADiv6 specification supports the following DP types:

The JTAG Debug Port (JTAG-DP)

The JTAG-DP is accessed by IEEE 1149.1-compliant DBGTAP scan chains to read and write register information.

- For more information about DBGTAP scan chains, see [Chapter B3 The JTAG Debug Port](#).
- *IEEE Standard 1149.1 Test Access Port and Boundary Scan Architecture* contains detailed information about the requirements for JTAG scan chains.

This specification is for JTAG-DP Protocol version 1. ADiv6 only permits use of JTAG-DP Protocol version 1. For details, see [Chapter B3 The JTAG Debug Port](#).

The Serial Wire Debug Port (SW-DP)

The SW-DP is a two-pin serial interface that uses a packet-based protocol to read or write registers. The protocol requires the following steps for communication between the host, which is the debugger, and the target, which is the ADI:

1. A host-to-target packet request, which includes whether the required access is to a DP register (DPACC) or to an AP register (APACC), and a two-bit register address.
2. A target-to-host acknowledge response.
3. A data transfer phase, if necessary. This phase can be target-to-host or host-to-target, depending on the request that is made in the first phase.

For details about the SW-DP protocol, see [Chapter B4 The Serial Wire Debug Port](#).

The Serial Wire/JTAG Debug Port (SWJ-DP)

The SWJ-DP interface combines the SWD and JTAG Data Link protocols using the following mechanism:

- The pins that carry the signals are shared between the two options.
- The debugger can select which of the protocols it wants to use.

For details about how to implement the SWJ-DP, see [Chapter B5 The Serial Wire/JTAG Debug Port](#).

A1.6 Access Ports (APs)

An AP uses a resource-specific transport mechanism to access debug information in the system to be debugged. The information is passed to the DP from the AP to be accessed by a debugger using a standardized protocol.

The implementation of an AP depends on the resources it accesses. This specification includes programmers' models for following two types of resources:

- Memory-mapped resources, such as debug peripherals, for which ADiv6 defines a MEM-AP programmers' model. For a complete description of the MEM-AP programmers' model, see [Guide to the detailed description of a MEM-AP on page A1-30](#).
- Legacy IEEE 1149.1 JTAG devices, for which ADiv6 defines a JTAG-AP and associated programmers' model. For a complete description of the JTAG-AP programmers' model, see [Guide to the detailed description of a JTAG-AP on page A1-31](#).

———— Note ————

The following applies to APs mentioned in this specification:

- Exact requirements are not specified for the transport between the AP and the resource. In particular, it does not require a MEM-AP to use a bus to connect to the system being debugged. For example, ADiv6 might be directly integrated into the resource. In logical terms, however, a MEM-AP always accesses a memory-mapped resource in the system being debugged, which is why this specification describes MEM-AP accesses to the system being debugged as memory accesses.
- In the future, more Arm APs might become available.
- An ADI can include APs that are specified by companies other than Arm.

All APs must follow a base standard for identification, and debuggers must be able to recognize and ignore Access Ports that they do not support. APs that comply with APv2, required by ADiv6, are Class 0x9 CoreSight components, and implement the CoreSight and APv2 programmers' models. For more information, see [Chapter C1 About the AP](#).

As described in [The subdivisions of an ADiv6 implementation on page A1-25](#):

- The simplest ADI has only one AP. This AP can be either a MEM-AP or a JTAG-AP.
- ADIs can have multiple APs. For example:
 - A mixture of MEM-APs and JTAG-APs.
 - All MEM-APs.
 - All JTAG-APs.
- Debuggers must be able to recognize and ignore unsupported APs.

For more information, see [Chapter C1 About the AP](#).

A1.6.1 Using the Debug Port to access Access Ports

[Figure A1-3 on page A1-30](#) shows the different levels between the physical connection to the debugger and the debug resources of the system being debugged. These levels are designed to enable efficient access to the system being debugged, and several levels provide registers within an implementation of the ADI. This section describes how these register accesses are implemented.

A DP supports two types of accesses: DP accesses and AP accesses. Because debuggers usually have serial interfaces, the methods of making these accesses are kept as short as possible, and all accesses are 32-bits.

The description that is given here is of scan chain access to the registers, from a debugger that is connected to a JTAG-DP. However, the process is similar when the access is from a SWD interface connection to an SW-DP. Differences when accessing the registers from a SWD interface connection are described in [Chapter B4 The Serial Wire Debug Port](#).

Every AP or DP access transaction from the debugger includes two address bits, A[3:2]:

- For a DP register access, the address bits A[3:2] and [SELECT.DPBANKSEL](#) determine which register is accessed.

- For an AP register access, `SELECT.ADDR` and `SELECT1.ADDR` are combined to form the 60-bit address of a bank of four AP registers in the 64-bit AP address space. Address bits `A[3:2]` are used to select one of the four registers in the bank, as shown in [Figure A1-3 on page A1-30](#).

Bits[1:0] of all AP and DP register addresses are `0b00`.

For example, to access register 3 in bank 1 in the AP that is located at address `0x0000000000000000`, the debugger must:

- Use two DP register writes to select bank 1 in the AP:
 - Write `0x00000000` to `SELECT1.ADDR`.
 - Write `0x00000001` to `SELECT.ADDR`.
- To read from register 3 in the selected bank, use an AP register access with `A[3:2] = 0b11`.

For every AP access, the DP combines `A[3:2]` with `SELECT1.ADDR` and `SELECT.ADDR` to generate the AP register address. The debugger can access any of the four registers from `0x10` to `0x1C` without changing `SELECT`.

This access model is shown in [Figure A1-3 on page A1-30](#). This figure shows how the contents of the [SELECT1 on page B2-76](#) and [SELECT on page B2-76](#) registers are combined with the `A[3:2]` bits of the APACC scan-chain to form the address of a register in an AP. Other parts of the JTAG-DP are also shown. These parts are explained in greater detail in later sections:

- [Figure C2-1 on page C2-173](#) for a MEM-AP implementation.
- [Figure C3-1 on page C3-244](#) for a JTAG-AP implementation.

These figures give more detail of the connections to the debug or system resources.

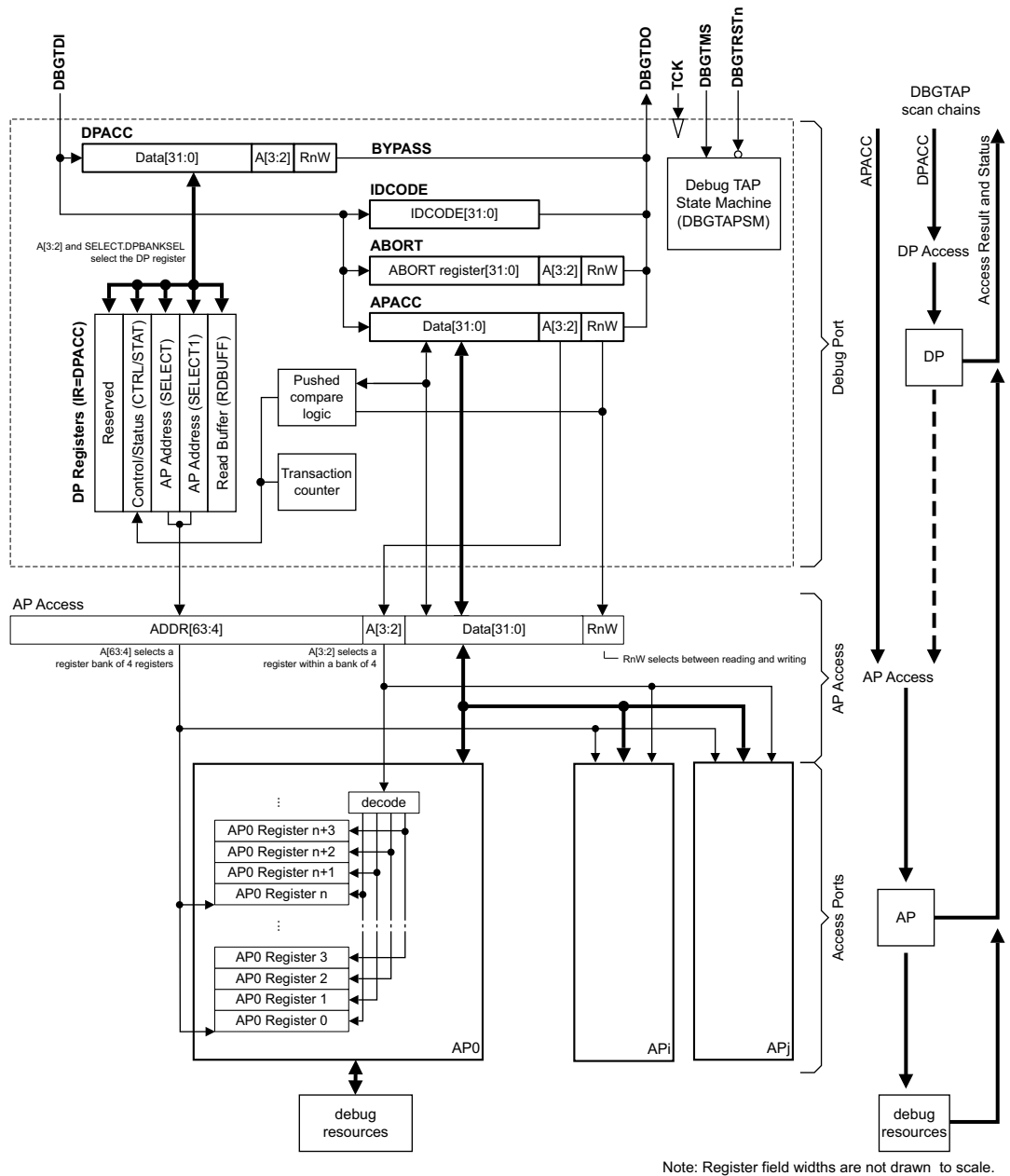

Figure A1-3 Structure of an ADIV6 implementation, showing DPv3 JTAG-DP accesses to a generic AP

A1.6.2 Guide to the detailed description of a MEM-AP

The operation and use of a MEM-AP must be understood within the context of interactions with all of the following components:

- The MEM-AP itself.
- The MEM-AP registers.
- The standard debug components registers that you access through the MEM-AP.

The MEM-AP is described in the following chapters of this specification:

- [Chapter C1 About the AP.](#)
- [Chapter C2 The Memory Access Port.](#)

The MEM-AP provides access to zero, one, or more debug components. Any debug component that complies with the Arm Generic Identification Registers specification implements a set of Component Identification Registers. These registers are described in *Arm® CoreSight™ Architecture Specification*.

If the MEM-AP connects to more than one debug component, the system that is accessed by the MEM-AP must also include at least one ROM Table. ROM Tables are accessed through a MEM-AP, and are described in [Chapter D1 About ROM Tables](#).

———— **Note** —————

As shown in [Design choices and implementation examples on page A1-32](#), a system with only one functional debug component might also implement a ROM Table.

MEM-APs that share resources could suffer from interdependencies. A twin MEM-AP solution, which allows external debuggers and on-chip software to reliably access MEM-APs that share hardware, is specified in [Twin MEM-APs on page C2-189](#).

A1.6.3 Guide to the detailed description of a JTAG-AP

To understand the operation and use of a JTAG-AP, you must understand:

- The JTAG-AP itself.
- The JTAG-AP registers.

The JTAG-AP is described in the following chapters of this specification:

- [Chapter C1 About the AP](#).
- [Chapter C3 The JTAG Access Port](#).

The JTAG-AP provides a standard JTAG connection to one or more legacy components. The connection between the JTAG-AP and the components is described by the *IEEE 1149.1-1990 IEEE Standard Test Access Port and Boundary Scan Architecture*. Details on how to use of this connection are outside the scope of this specification.

A1.6.4 Using the AP to access debug resources

Accessing the AP gives access to the system being debugged, which is shown as access to Debug resources in [Figure A1-3 on page A1-30](#).

In summary:

- In a MEM-AP, the debug resources are logically memory-mapped. [Chapter C2 The Memory Access Port](#) section [MEM-AP register accesses and memory accesses on page C2-175](#) describes the method for accessing these resources. The connection between the MEM-AP and a debug resource, however, is outside the scope of this specification.
- In a JTAG-AP, the debug resources are connected through a standard JTAG serial connection, as defined in *IEEE 1149.1-1990 IEEE Standard Test Access Port and Boundary Scan Architecture*. For more information about accessing the resources, see [Chapter C3 The JTAG Access Port](#).

A1.7 Design choices and implementation examples

Figure A1-2 on page A1-25 introduces the components that comprise an ADI.

Before implementing an ADI, certain design choices must be made, as described in this section about following functional blocks of the interface:

- Choices for the DP.
- Choices for the APs.

———— **Note** ————

This specification is written for engineers implementing an ADI, and for engineers using an ADI. The design choices outlined in this specification for a debug interface have an implicit purpose. If the reasoning behind the design choices are not explicit, the implementer of the debug interface must be contacted for further information.

A1.7.1 Choices for the DP

The DP determines which type of physical connection the ADI presents to the debugger. Each implementation of the ADI provides a single DP that provides the physical connection for the design. You can choose from the following DP types:

- JTAG-DP.
- SW-DP.
- SWJ-DP.

———— **Note** ————

The following applies to DPs mentioned in this document:

- In an illustration of an ADI, a component that is labeled DP can represent any of the available options.
- Arm might define more DP types in the future.

A1.7.2 Choices for the APs

A simple ADI uses a single AP to connect to a single debug component, for example:

- A MEM-AP that connects to a single microprocessor core, as shown in Figure A1-4.
- A JTAG-AP that connects to a single legacy IEEE 1149.1 device, as shown in Figure A1-5 on page A1-33.

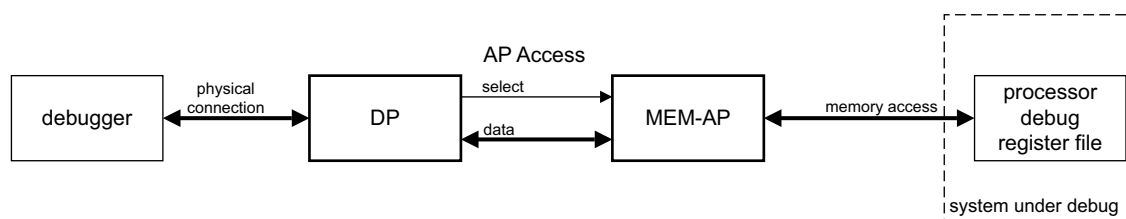

Figure A1-4 Simple ADI MEM-AP Implementation

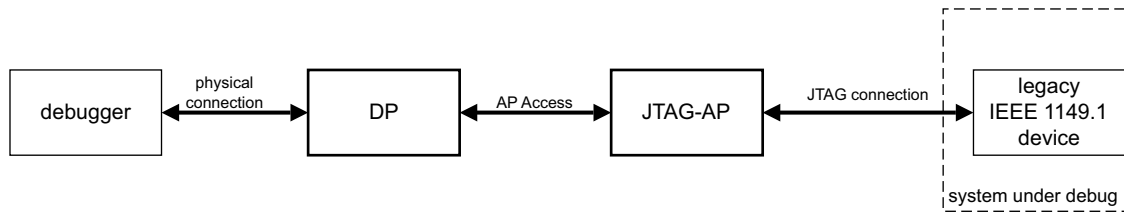

Figure A1-5 Simple ADI JTAG-AP Implementation

A system with only a single debug component often implements a ROM table, as explained in [ROM Tables on page C2-172](#) and shown in [Figure A1-6](#).

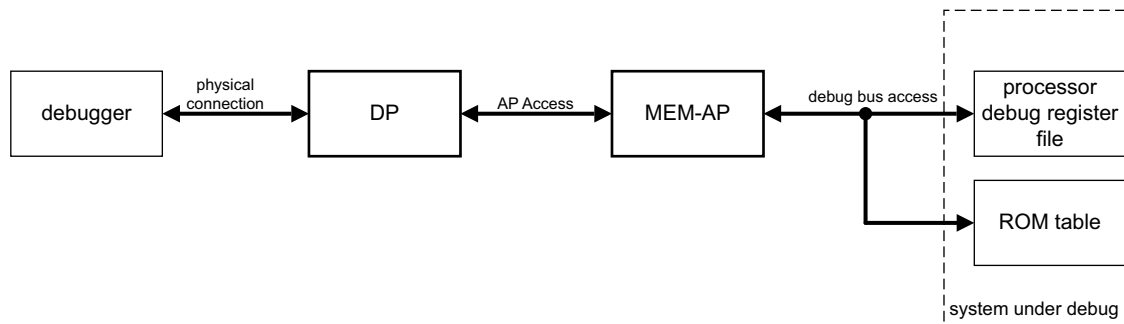

Figure A1-6 Simple example of an ADI implementation, with ROM Table

Because a single ADI can include multiple APs, design choices for APs must be made at two levels:

- Choosing the number of APs in the ADI, and the type of each AP. These decisions are outlined in [Top-level AP planning choices](#).
- The choices that have to be made for each implemented AP, as outlined in the following sections:
 - [Choices for JTAG-APs on page A1-35](#).
 - [Choices for MEM-APs on page A1-35](#).

Top-level AP planning choices

In a more complex system, there can be multiple APs. Each AP can be connected to multiple components, or multiple address spaces. An AP can be implemented as one of the following three types:

- As a MEM-AP with a memory-mapped debug bus connection. The debug bus connects directly to one or more debug register files.
- As a MEM-AP with a memory-mapped system bus connection. The MEM-AP connection to the system bus provides access to one or more debug register files.
- As a JTAG-AP. A JTAG-AP connects directly to one or more JTAG devices, and enables connection to legacy hardware components.

———— **Note** —————

The connection between legacy hardware components and a JTAG-AP is defined by the JTAG standard. For more information, see [Chapter C3 The JTAG Access Port](#).

Depending on the debug components of the system to which the ADI will connect, the amount of various types of APs must be decided beforehand.

Figure A1-7 shows a more complex ADI and illustrates the different AP types.

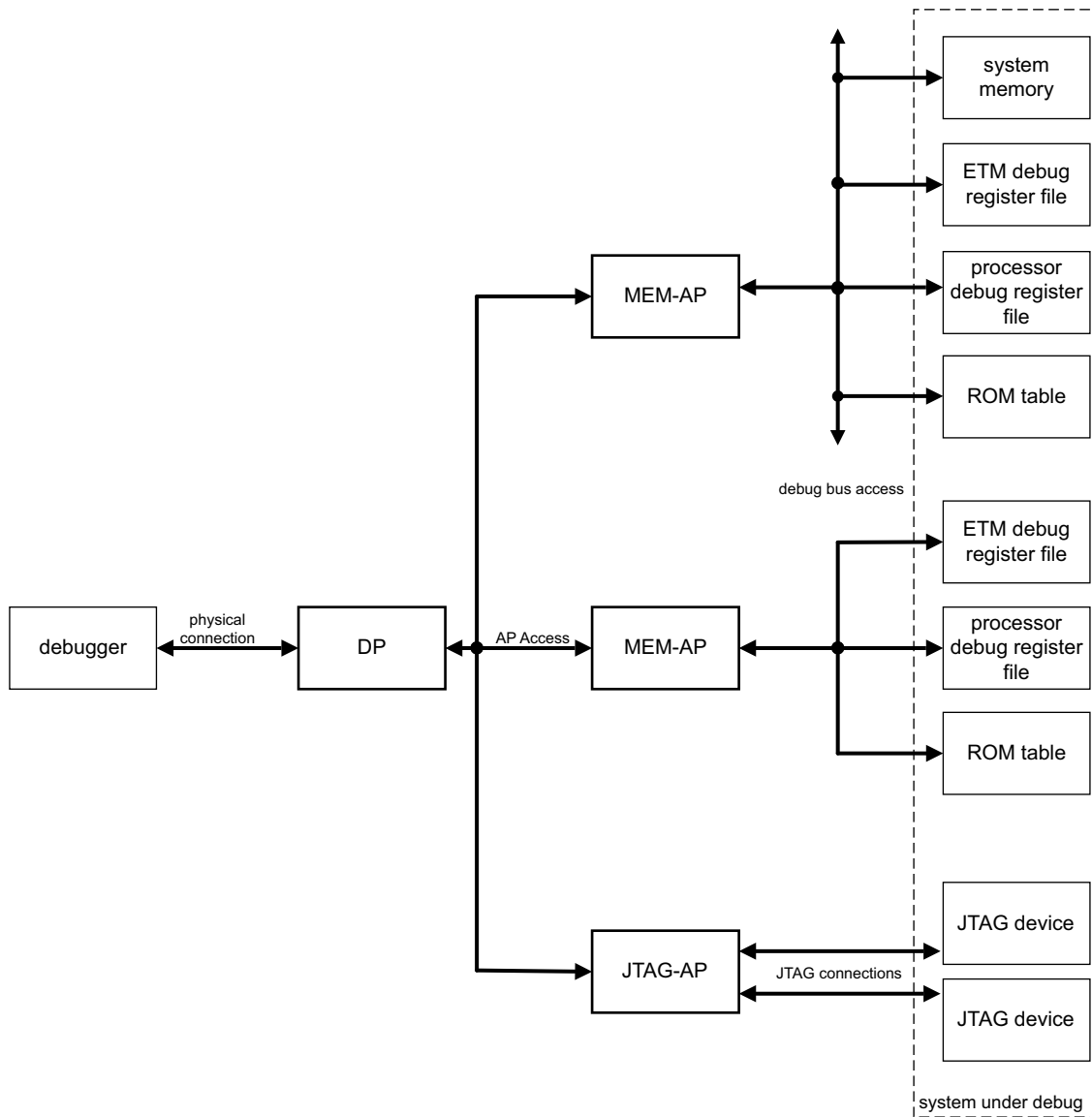

Figure A1-7 Complex Arm Debug Interface that uses several AP types

The ADIV6 architecture specification supports the following features:

- An implementation of the ADI is permitted to contain multiple APs.
- A single MEM-AP is permitted to access multiple register files.
- An AP is permitted to access a mixture of system memory and debug register files.

When implementing these features, however, you must observe the following conditions:

- Every AP must follow the basic standard for identification that is described in this specification.
- Debuggers must have a way to ignore APs that they do not recognize.

In illustrations such as [Figure A1-3 on page A1-30](#), the DP can be of any DP type that is defined by ADIV6.

Choices for MEM-APs

The following design decisions must be made for a MEM-AP:

Decisions that depend on the requirements of those debug components

The main decisions to be made for a MEM-AP concern the connection between the MEM-AP and the memory-mapped debug components that are connected to it. These decisions include:

- Whether a bus is required for this connection.
- The width of the bus, if implemented.
- The memory map of the MEM-AP address space.

Inclusion of a ROM Table

If a MEM-AP connects to more than one debug component, the system must include one or more ROM Tables to provide information about the debug system. A system that has only one other component does not require a ROM Table, but a system designer might choose to include one anyway. For more information, see [ROM Tables on page C2-172](#).

The inclusion of IMPLEMENTATION DEFINED MEM-AP features

- Certain features must be included if the connection is less than 32-bits wide.
- The debug components can place limitations on the connection, for example a component might require 32-bit access.

For more information about conditional MEM-AP features, see:

- [MEM-AP functions on page C2-177](#).
- [MEM-AP implementation requirements on page C2-193](#).

For detailed information about implementing a MEM-AP, see [Chapter C2 The Memory Access Port](#).

Choices for JTAG-APs

The following design decisions must be made for a JTAG-AP:

The number of JTAG scan chains that are connected to the JTAG-AP

A single JTAG-AP can connect to up to eight JTAG scan chains. These scan chains can be split across multiple devices or components within the system being debugged.

The number of TAPs in each scan chain

A single JTAG scan chain can contain multiple *Test Access Ports* (TAPs). However, Arm recommends that each scan chain connected to a JTAG-AP contains only one TAP.

For more information, see [Chapter C3 The JTAG Access Port](#).

A1.8 Power Requests

CDBGPWRUPREQ and **CSYSPWRUPREQ**, which are described in [Power control requirements and operation on page B2-84](#), are pieces of DP functionality that are not directly accessible to functional networks, and therefore the *Granular Power Requester* (GPR) is the primary power request functionality. The GPR functionality is incorporated in standalone components and optionally in ROM Tables.

The existing standalone GPR programmers model is deprecated in favor of integrating the GPR functionality into the ROM Table. The ROM Table programmers model including the GPR functionality is described in [Power domain entries on page D3-319](#).

The components in each power domain are identified in the ROM Table that points to those components, providing the ability for a debugger to detect the power domain of debug components, and request power for only the domains that require power at a certain time. The GPR supports up to 32 debug power domains.

To support requesting power to other parts of the system, the GPR functionality is extended to support power requests for up to 32 further power domains, which are not defined in a ROM Table and are IMPLEMENTATION DEFINED. These power domains are referred to as system power domains. System power domains might contain components that must be accessible to a debugger, even though they do not have any debug functionality that is described in a ROM Table. Examples include system interconnect configuration components.

To enable a debugger that is connected via a functional network to successfully debug the system, the first GPR must be accessible at the entry point into the system to ensure that the debugger can request power to the rest of the system. Therefore, the first ROM Table, and the associated GPR, must always be accessible when the debug link is powered and operational. This GPR must be one of the following:

- A GPR that is incorporated into the ROM Table.
- A separate GPR which is always accessible when the ROM is accessible.

An example of a system with a GPR that is incorporated into the ROM Table is shown in [Figure A1-8 on page A1-37](#).

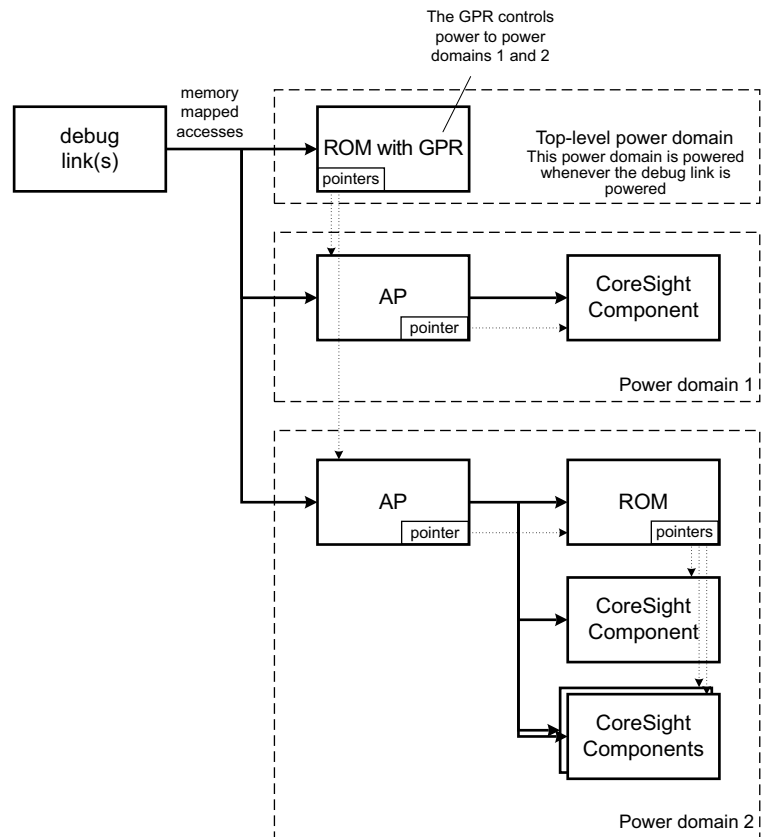

Figure A1-8 Example power domains with a top-level power domain at the first level

The power control registers in the ROM Table can be used to issue power requests:

- The debug power control registers, [DBGPCR<n>](#), can be used to request power for up to 32 debug power domains, as described in [Debug power requests on page D3-320](#).
- The system power control registers, [SYSPCR<n>](#), can be used to request power for up to 32 system power domains, as described in [System power requests on page D3-323](#).

For detailed descriptions of the ROM Table registers, see [Register descriptions on page D3-328](#).

Part B

The Debug Port

Chapter B1

About the DP

This part describes the features that are implemented by the DP.

This specification is for DP architecture version DPv3. ADIV6 only permits use of DPv3.

———— **Note** —————

DPv3 is not fully backwards compatible with earlier DP versions. For a description of an earlier version of the DP architecture, see the relevant version of the ADI architecture specification.

A DP can be implemented as a JTAG-DP, a SW-DP, or a combined SWJ-DP.

Requirements that apply to all DP types are described in the following sections in this chapter:

- *MINDP, Minimal DP extension on page B1-42.*
- *Sticky flags and DP error responses on page B1-43.*
- *The transaction counter on page B1-45.*
- *Pushed-compare and pushed-verify operations on page B1-46.*
- *Power and reset control on page B1-48.*

Reference information for all DP types is described in the following chapter:

- *Chapter B2 DP Reference Information.*

Specific information for each of the DP types is described in the following chapters:

- *Chapter B3 The JTAG Debug Port.*
- *Chapter B4 The Serial Wire Debug Port.*
- *Chapter B5 The Serial Wire/JTAG Debug Port.*

B1.1 MINDP, Minimal DP extension

The *Minimal Debug Port* (MINDP) programmers' model is a simplified version of the DP that is intended for low gate-count implementations. MINDP implementations must use DPv1 or later.

MINDP implementations must omit the following DP features:

- Pushed-verify operation.
- Pushed-compare operation.
- The transaction counter.

MINDP implementations must observe the following conventions:

- The [DPIDR](#).MIN field is RAO.
- The following fields of the [CTRL/STAT](#) register are RES0:
 - TRNCNT.
 - MASKLANE.
 - STICKYCMP.
 - TRNMODE.See also [CTRL/STAT](#).
- The [ABORT](#).STKCMPLR field is SBZ. Writing 0b1 to this bit is UNPREDICTABLE.

B1.2 Sticky flags and DP error responses

Sticky flags signal transaction errors and are persistent between transactions. When set, a sticky flag remains set until the debugger actively clears it, even if the condition that caused the flag to be set no longer applies.

In the [CTRL/STAT](#) register, the sticky error flags are:

- STICKYERR, bit[5].
- STICKYCMP, bit [4].
- STICKYORUN, bit[1].
- WDATAERR, bit[7], SW-DP only.

After performing a series of APACC transactions, a debugger must check the [CTRL/STAT](#) register to check if an error occurred. If the debugger finds that a sticky flag is set, it clears the flag, and, if necessary, initiates extra APACC transactions to determine why the sticky flag was set. Because the flags are sticky, the debugger does not have to check the flags after every transaction, and must only check the [CTRL/STAT](#) register periodically, which reduces the overhead of checking for errors.

When an error is flagged, the current transaction is completed and subsequent APACC transactions are discarded until the sticky flag is cleared.

The DP response to an error condition and the method to clear the sticky flags depends on the DP type:

- An SW-DP immediately signals an error response.
- A JTAG-DP immediately discards all transaction and marks them as complete.

For details on how to clear the sticky flags for each DP type, see the descriptions of the sticky flag fields in [CTRL/STAT, Control/Status register on page B2-57](#).

If pushed transactions are supported, the sticky flag [CTRL/STAT.STICKYCMP](#) reports the result of pushed operations, see [Pushed-compare and pushed-verify operations on page B1-46](#). [CTRL/STAT.STICKYCMP](#) behaves in the same way as the sticky flags described in this section.

The DP uses the sticky flags in the [CTRL/STAT](#) register to signal the following transaction errors:

Read and write errors

A read or write error can occur in the DP, an AP, or the resource being accessed. In every case, when the error is detected, the Sticky Error flag [CTRL/STAT.STICKYERR](#) is set to 0b1.

For example, a read or write error might occur if the debugger makes an AP transaction request while the debug power domain is powered down. See [Power and reset control on page B1-48](#) for information about power domains.

Overrun detection

DPs support an overrun detection mode, which enables a debugger to send blocks of commands using a connection with high latency and high throughput. These commands must be sent with sufficient in-line delays to make overrun errors unlikely. To implement an overrun detection mode, the DP can be programmed to set the Sticky Overrun flag, [CTRL/STAT.STICKYORUN](#), to 0b1 if an overrun error occurs. In overrun detection mode, the debugger must check the Sticky Overrun flag for overrun errors after each sequence of APACC transactions.

Overrun detection mode is enabled by setting the Overrun Detect bit, [CTRL/STAT.ORUNDETECT](#), to 0b1.

Due to the differences between the JTAG-DP and the SW-DP, their behavior in overrun detection mode is DATA LINK DEFINED:

JTAG-DP If the response to any transaction is not OK, the Sticky Overrun flag, [CTRL/STAT.STICKYORUN](#), is set to 0b1.

The response to a transaction is WAIT until the previous AP transaction is complete. Once the AP transaction has completed, the response is FAULT.

Subsequent APACC transactions respond with FAULT, because the STICKYORUN bit is set to 0b1. Subsequent DPACC transactions, however, respond with OK, in particular to be able to access the [CTRL/STAT](#) register to confirm the Sticky Overrun flag status,

and to clear the flag, after gathering any required information about the overrun condition. See also [Sticky overrun behavior on DPACC and APACC accesses on page B3-105](#).

SW-DP If the response to any transaction is not OK, the Sticky Overrun flag, `CTRL/STAT.STICKYORUN`, is set to `0b1`.
If a previous AP transaction is incomplete, the first response to a transaction is WAIT. Subsequent responses are FAULT, because the STICKYORUN flag is `0b1`. See [Sticky overrun behavior on page B4-123](#).
The value of the Sticky Error flag, `CTRL/STAT.STICKYERR`, is not changed.

Note

The method for clearing the STICKYORUN flag depends on whether the DP type is SW-DP or JTAG-DP. See the descriptions of the STICKYORUN field in [CTRL/STAT, Control/Status register on page B2-57](#) for more information.

If a new transaction results in an overrun error while an earlier transaction is incomplete, the earlier transaction completes normally. Other sticky flags, however, might be set to `0b1` during completion of the earlier transaction.

If the debugger clears the ORUNDETECT flag while STICKYORUN is `0b1`, the resulting value of STICKYORUN is UNKNOWN.

To leave overrun detection mode, a debugger must perform the following steps:

1. Check the value of the `CTRL/STAT.STICKYORUN` flag.
2. If the STICKYORUN flag is `0b1`, clear it to `0b0`.
3. To disable overrun detection mode, clear the ORUNDETECT flag to `0b0`.

Protocol errors (SW-DP only)

The SW-DP can generate protocol errors, for example in the case of wire-level errors.

Note

Although protocol errors can only occur in the SW-DP, they are described in this chapter because they are part of the sticky flags error-handling mechanism.

The required response is as follows:

- If the SW-DP detects a protocol error in a packet request, the DP does not respond to the message.
- If the SW-DP detects a parity error in the data phase of a write transaction, it sets the Sticky Write Data Error flag, `CTRL/STAT.WDATAERR`. The Sticky Write Data Error flag is treated in the same way as the other sticky flags described in this section.

For more information, see [Parity on page B4-116](#) and [Protocol error response on page B4-122](#).

B1.3 The transaction counter

Except for MINDP implementations, DPs must include an AP transaction counter, [CTRL/STAT.TRNCNT](#). The transaction counter enables a debugger to generate a sequence of AP transactions with a single AP transaction request. With a MEM-AP access, the transaction counter enables an AP transaction to generate a sequence of accesses to the connected memory system.

———— **Note** —————

Each AP defines which registers support sequences of transactions. If an AP register does not support sequences of transactions, or [SELECT.ADDR](#) selects an AP that is not present, then the result of a sequence of transactions to that register is UNPREDICTABLE. Reserved AP registers and the common AP [IDR](#) do not support sequences of transactions.

Examples of the use of the transaction counter are:

Memory fill operations

To facilitate memory fill operations, the transaction counter can repeatedly write a single data value that is supplied in an AP transaction request. The MEM-AP includes a mechanism that initiates a series of AP accesses and automatically increments the access address after each AP access. This mechanism results in the supplied data value being written to a sequence of memory addresses under the control of the transaction counter. For more information, see [Packed transfers on page C2-187](#).

Fast searches and memory verification

To perform a fast search, or verify of an area of memory, the transaction counter can be used when reading from the [DRW](#) register, with pushed-compare or pushed-verify operations enabled. For examples of this application, see [Pushed-compare and pushed-verify operations on page B1-46](#), and, for more details, [Example of using the transaction counter for a pushed-compare operation on a MEM-AP on page C2-197](#).

Writing a value other than zero to the [CTRL/STAT.TRNCNT](#) field generates multiple AP transactions. For example, writing `0x001` to this field generates two AP transactions, and writing `0x002` generates three transactions.

If the transaction counter is not zero, it is decremented after each successful transaction. If one of the following is true, the transaction counter is not decremented and the transaction is not repeated:

- The transaction counter is zero.
- The [CTRL/STAT.STICKYERR](#) flag is `0b1`.
- The [CTRL/STAT.STICKYCMP](#) flag is `0b1`.

If a sequence of operations is terminated because the Sticky Error or Sticky Compare flag was set to `0b1`, the transaction counter remains at the value from the last successful transaction. This enables the software to recover the location of the error or determine where the compare or verify operation terminated.

The transaction counter does not automatically reload when it reaches zero.

B1.4 Pushed-compare and pushed-verify operations

The DP supports pushed operations. Pushed operations improve performance where writes might be faster than reads. They are used as part of in-line tests, for example Flash ROM programming and monitor communication.

Pushed operations use the following mechanism:

1. The debugger initiates an AP write transaction. The value to be written is stored in the DP.
2. The DP reads a value from the AP.

———— **Note** —————

Whenever an AP write transaction is performed with pushed-compare or pushed-verify enabled, the AP access that results is a read operation, not a write.

3. The DP then compares the two values and updates the Sticky Compare flag, `CTRL/STAT.STICKYCMP`, based on the result of the comparison. Whenever the `STICKYCMP` bit is set to `0b1` in this way, any outstanding transaction repeats are canceled.

———— **Note** —————

Performing an AP read transaction with pushed-compare or pushed-verify enabled causes UNPREDICTABLE behavior.

If an SW-DP performs an AP read transaction with pushed-compare or pushed-verify, an UNKNOWN value is returned, and the read has UNPREDICTABLE side effects, even though the wire-level protocol remains coherent.

Each AP defines which registers support pushed transactions. If an AP register does not support pushed transactions, or `SELECT.ADDR` selects an AP that is not present, a pushed transaction sets `STICKYCMP` to an UNKNOWN value. Reserved AP registers and the common AP `IDR` do not support pushed transactions.

To configure pushed operations, use the `CTRL/STAT` register:

1. Enable the appropriate transfer mode using the Transfer Mode field, `TRNMODE`:
 - A value of `0b01` in `TRNMODE` selects pushed-verify operations: if the values match, the `STICKYCMP` flag is set to `0b1`.
 - A value of `0b10` in `TRNMODE` selects pushed-compare operations: if the values do not match, the `STICKYCMP` flag is set to `0b1`.
2. Select the byte lanes to be included in the comparison using the byte lane mask field, `MASKLANE`. A value of `0b1` for bit n of `MASKLANE` includes byte n of the APACC write value and the current AP value in the comparison. For details about the `MASKLANE` field, see [CTRL/STAT, Control/Status register on page B2-57](#).

The following are examples of applications of pushed-verify and pushed-compare MEM-AP operations:

- Pushed-verify can be used to verify the contents of system memory. A series of expected values are written as AP transactions. With each write, the pushed-verify logic initiates an AP read access, and compares the result of this access with the expected value. If the values do not match, the `CTRL/STAT.STICKYCMP` flag is set to `0b1`. This operation is described in more detail in [Example of using a pushed-verify operation on a MEM-AP on page C2-196](#).
- Pushed-compare can be used to search system memory for a given value. However, this feature is most useful when it is performed using the AP transaction counter, which is described in [The transaction counter on page B1-45](#). This operation is described in more detail in [Chapter C2 The Memory Access Port section Example of using the transaction counter for a pushed-compare operation on a MEM-AP on page C2-197](#).

The following example describes pushed operations on a specific AP, which makes it easier to understand how pushed operations are implemented. Consider an AP write transaction to the Data Read/Write (`DRW`) register in a MEM-AP with a `TRNMODE` value of `0b10`, and a `MASKLANE` value of `0b0101`. The following actions take place:

1. The DP holds the data value from the AP write transaction in the pushed-compare logic, see [Figure A1-3 on page A1-30](#).
2. The AP reads from the address indicated by the MEM-AP Transfer Address Register (`TAR`).

3. The value that is returned by this read is compared with the value held in the pushed-compare logic. The comparison is masked using the value of MASKLANE. The example value, 0b0101, includes byte lanes zero and two in the comparison. The result is either a match or a mismatch.
4. In the example, the TRNMODE value of 0b10 selects pushed-compare operations:
 - If the result of the comparison was a mismatch, the CTRL/STAT.STICKYCMP flag is set to 0b1 and any outstanding transactions are canceled.
 - If the result of the comparison was a match, nothing happens.

B1.5 Power and reset control

The DP supports the following power and reset control fields in the [CTRL/STAT](#) register:

- Control fields for system and debug power control, CDBGPWRUPREQ, CDBGPWRUPACK, CSYSPWRUPREQ, and CSYSPWRUPACK. For more information, see [System and debug power control behavior on page B2-82](#).
- Control fields for debug reset control, CDBGRSTREQ and CDBGRSTACK. For more information, see [Debug reset control behavior on page B2-87](#).

These control bits are programmable by the debugger, and drive signals into the target system.

When controlled by the power and reset control fields in the [CTRL/STAT](#) register, a debug logic reset can be achieved by using the CDBGRSTREQ field, but [CTRL/STAT](#) does not provide any control bits for requesting a system reset. However, it is common for the physical interface to the debugger to include a system reset pin, **nSRST**. This is intended to provide requests or stimuli into existing power and reset controllers. For details about how to implement a system reset pin, see [System reset control behavior on page B2-89](#).

Arm recommends using CDBGRSTREQ only as a last resort to unblock a locked up system. CDBGRSTREQ might affect more than just locked up logic and must be used carefully.

nSRST might also cause a reset of debug logic, but is required to release the reset of debug logic to allow a debugger to program the debug logic while holding the system in reset.

ADI does not replace the system power and reset controllers. This specification does not place any requirements on the operation of system power and reset controllers.

Chapter B2

DP Reference Information

This chapter contains the following reference information for the DP:

- *DP architecture versions* on page B2-50.
- *DP register descriptions* on page B2-53.
- *System and debug power control behavior* on page B2-82.
- *Debug reset control behavior* on page B2-87.

B2.1 DP architecture versions

This section introduces the concept of DP architecture versions and describes the DP registers for the DP architecture version DPv3. It contains the following subsections:

- [DP architecture versions summary](#).
- [DP architecture version 3 \(DPv3\) address map on page B2-51](#).

One of the significant differences between the JTAG-DP and the SW-DP is how the registers are accessed. For this reason, the tables that describe the registers do not include register address information. This information is included at the start of the detailed description of each register for each DP type.

Several aspects of the DP architecture are DATA LINK DEFINED, and described in the following chapters:

- [Chapter B3 The JTAG Debug Port](#).
- [Chapter B4 The Serial Wire Debug Port](#).
- [Chapter B5 The Serial Wire/JTAG Debug Port](#).

B2.1.1 DP architecture versions summary

Every ADI includes a single DP that is compliant with one of the DP architecture versions. [Table B2-1](#) shows the DP architecture versions.

Table B2-1 DP architecture versions

Version number	Description	Debug Port Support	Notes
DPv0	DP architecture version 0	JTAG-DP	JTAG-DP in ADIV5.0
DPv1	DP architecture version 1	SW-DP, JTAG-DP	SW-DP in ADIV5.0
DPv2	DP architecture version 2	SW-DP, JTAG-DP	SW-DP version 2 in ADIV5.1
DPv3	DP architecture version 3	SW-DP, JTAG-DP	

Although the DP architecture versions are different, their register sets are similar, as summarized in [Table B2-2](#). For details about how the register is implemented in a specific architecture version and if the implementation is DATA LINK DEFINED, see [DP register descriptions](#).

Table B2-2 Summary of DP registers

Name	DP architecture version			
	DPv0	DPv1	DPv2	DPv3
ABORT	Yes	Yes	Yes	Yes
DPIDR	No	Yes	Yes	Yes
DPIDR1	No	No	No	Yes
BASEPTR0	No	No	No	Yes
BASEPTR1	No	No	No	Yes
CTRL/STAT	Yes	Yes	Yes	Yes
SELECT	Yes	Yes	Yes	Yes
SELECT1	No	No	No	Yes
RDBUFF	Yes	Yes	Yes	Yes
DLCR	No	Yes	Yes	Yes

Table B2-2 Summary of DP registers (continued)

Name	DP architecture version			
	DPv0	DPv1	DPv2	DPv3
RESEND	No	Yes	Yes	Yes
TARGETID	No	No	Yes	Yes
DLPIDR	No	No	Yes	Yes
TARGETSEL	No	No	Yes	Yes

B2.1.2 DP architecture version 3 (DPv3) address map

DPv3 modifies the DP register map in the following ways:

- Modified [DPIDR](#) to include DPv3 as a permitted version.
- Extends the [SELECT](#) register and introduces the [SELECT1](#) register to support 64-bit system addresses.
- Introduces support for JTAG DP Protocol version 1.
- Introduces definitions for the following registers:
 - The Debug Port Identification Register 1, [DPIDR1](#).
 - The Base Pointer Registers, [BASEPTR0](#)-[BASEPTR1](#).

The [SELECT](#).DPBANKSEL field determines which register is accessed at addresses 0x0 and 0x4.

[Table B2-3](#) shows the DPv3 register map.

Table B2-3 DPv3 address map

Address ^a	DPBANKSEL ^b	Name	Access	Notes
0x0	0x0	DPIDR	RO	-
	0x1	DPIDR1	RO	-
	0x2	BASEPTR0	RO	-
	0x3	BASEPTR1	RO	-
	0x4-0xF	-	RO	Reserved, RES0.
	x	-	WO	DATA LINK DEFINED, as either: <ul style="list-style-type: none"> • ABORT, see ABORT, Abort register on page B2-53 • Reserved, RES0
0x4	0x0	CTRL/STAT	RW	-
	0x1	DLCR	RW	-
	0x2	TARGETID	RO	-
	0x3	DLPIDR	RO	-
	0x4	EVENTSTAT	RO	-
	0x5	SELECT1	WO	-
All other values	-	-	-	Reserved, RES0

Table B2-3 DPv3 address map (continued)

Address ^a	DPBANKSEL ^b	Name	Access	Notes
0x8	x	-	RO	DATA LINK DEFINED
		SELECT	WO	-
0xC	x	RDBUFF	RO	-
		-	WO	DATA LINK DEFINED

a. Bits [1:0] of the address are always 0b00.

b. SELECT.DPBANKSEL field.

The ability to request a transaction abort using the **ABORT** register is optional in the DP:

- Whether the **ABORT** register is implemented is IMPLEMENTATION DEFINED.
- If the **ABORT** register is implemented, how it is accessed is DATA LINK DEFINED:
 - If defined by the data link, DP register 0 is reserved for this purpose.
 - In JTAG-DP, the **ABORT** register is implemented through the **ABORT** instruction.
- If the **ABORT** register is implemented in the DP, it is optional whether an outstanding transaction to an AP is aborted. If a transaction in progress cannot be aborted, it is permitted that access to a component is not possible without resetting the system.

Arm recommends that a DP implements the ability to request aborts.

B2.1.3 Register maps, and accesses to reserved addresses

The register memory maps for the DP and the AP are shown in:

- [Figure A1-3 on page A1-30](#), for accesses to JTAG-DP registers.
- [Figure C2-1 on page C2-173](#), for accesses to MEM-AP registers.
- [Figure C3-1 on page C3-244](#), for accesses to JTAG-AP registers.

There are several reserved addresses in these register maps. Reserved AP registers are RES0.

B2.2 DP register descriptions

This section gives full descriptions of the DP registers.

The registers are listed alphabetically by name.

B2.2.1 ABORT, Abort register

The **ABORT** register characteristics are:

Purpose The **ABORT** register forces an AP transaction abort.

From a software perspective, an abort is a fatal operation. It discards any outstanding and pending transactions, and leaves the AP in an UNPREDICTABLE state. On an SW-DP, however, the sticky error bits are not cleared to 0b0.

Writing 0b1 to the **ABORT.DAPABORT** register bit generates an AP abort, causing the current AP transaction to abort. This action also terminates the transaction counter, if it was active. It is IMPLEMENTATION DEFINED whether the AP propagates the abort, for example by aborting a transaction in progress.

After an AP abort:

- It is IMPLEMENTATION DEFINED which registers, if any, in the AP that was aborted can be accessed. If the register cannot be accessed, the DP returns a WAIT response to an AP access to the register. Arm recommends that any AP register that is not directly related to a stalling transaction is accessible, to allow a debugger to diagnose the cause of the error.
- DP accesses or AP accesses to any other APs or other components are accepted by the DP.

Caution

Use this function only in extreme cases, when debug host software has observed stalled target hardware for an extended period. Stalled target hardware is indicated by repeated WAIT responses.

Usage Constraints

The register is accessible as follows:

Default

WO

Configurations

Included in all implementations.

Attributes

A 32-bit write-only DP architecture register.

Field descriptions

The **ABORT** bit assignments are:

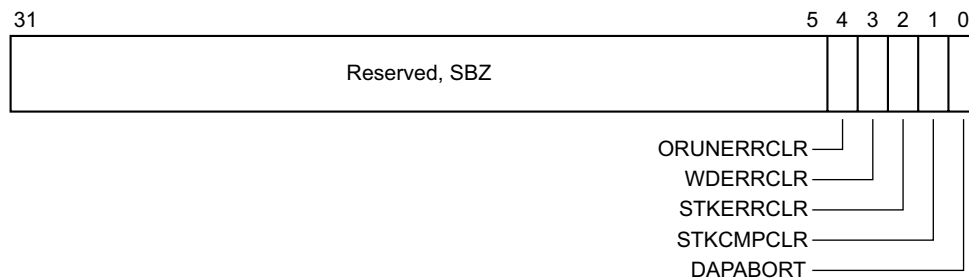

Bits[31:5]

Reserved, SBZ.

ORUNERRCLR, bit[4]

To clear the **CTRL/STAT.STICKYORUN** overrun error bit to 0b0, write 0b1 to this bit.

WDERRCLR, bit[3]

To clear the **CTRL/STAT.WDATAERR** write data error bit to 0b0, write 0b1 to this bit.

STKERRCLR, bit[2]

To clear the **CTRL/STAT.STICKYERR** sticky error bit to 0b0, write 0b1 to this bit.

STKCMPCLR, bit[1]

To clear the **CTRL/STAT.STICKYCMP** sticky compare bit to 0b0, write 0b1 to this bit. It is IMPLEMENTATION DEFINED whether the **CTRL/STAT.STICKYCMP** bit is implemented. See *MINDP, Minimal DP extension* on page B1-42.

DAPABORT, bit[0]

To generate an AP abort, which aborts the current AP transaction, write 0b1 to this bit.

Do this write only if the debugger has received WAIT responses over an extended period.

Accessing ABORT

Access to **ABORT** is DATA LINK DEFINED:

JTAG-DP Access is through its own scan-chain. See the *ABORT, JTAG-DP Abort register* on page B3-100.

SW-DP Accessed by a write to offset 0x0 of the DP register map.

Location	Offset
DP register map	0x0

B2.2.2 BASEPTR0-BASEPTR1, Base Pointer 0 and 1

The [BASEPTR0-BASEPTR1](#) characteristics are:

Purpose

[BASEPTR0](#) and [BASEPTR1](#) provide an initial system address for the first component in the system. Typically, the system address is the address of a top-level ROM Table which indicates where APv2 APs are located.

The size of the address is defined in [DPIDR1.ASIZE](#). [DPIDR1.ASIZE](#) defines the size of the whole address including bits[11:0], even though bits[11:0] are always zero. For example, if [DPIDR1.ASIZE](#) indicates a 32-bit address, the value of [BASEPTR0](#) indicates bits[31:0] of the base address, bits[11:0] always zero. Unimplemented bits are RES0.

Usage Constraints

If [DPIDR1.ASIZE](#) indicates a 12-bit address, all bits comprising the fields [BASEPTR0.PTR](#) and [BASEPTR1.PTR](#) are RES0. To indicate that there is a component at address 0x000, [BASEPTR0.VALID](#) must be set to 0b1. If there is no component at address 0x000, [BASEPTR0.VALID](#) must be set to 0b0.

The register is accessible as follows:

Default

RO

Configurations

Included in all implementations.

Attributes

A set of two 32-bit DP architecture registers.

Field descriptions

The [BASEPTR0-BASEPTR1](#) bit assignments are:

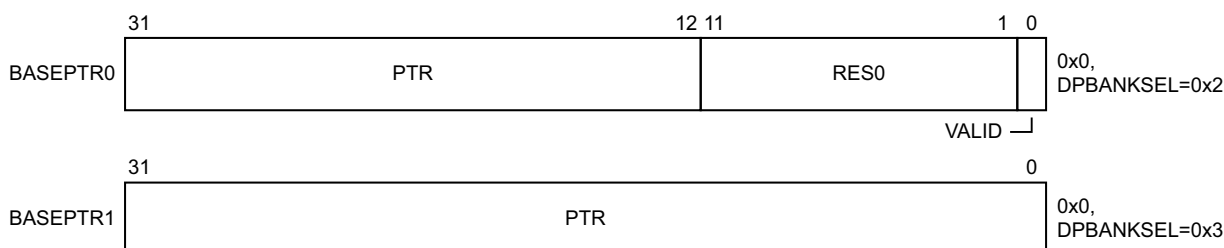

PTR, BASEPTR1[31:0] : BASEPTR0 bits[31:12]

The base address of the first component in the system, formed by concatenating bits[31:0] of [BASEPTR1](#) with bits[31:12] of [BASEPTR0](#). [BASEPTR1.PTR](#) provides bits [63:32] of the base address, and [BASEPTR0.PTR](#) provides bits [31:12] of the base address.

The address is aligned to a 4KB boundary.

Bits[11:1] of BASEPTR0

Reserved, RES0.

VALID, BASEPTR0 bit[0]

Indicates whether the PTR field specifies a valid base address. This field can have one of the following values:

- 0b0 No valid base address is specified. The value of the PTR field is UNKNOWN.
- 0b1 The PTR field specifies a valid base address.

Accessing BASEPTR0-BASEPTR1

BASEPTR0-BASEPTR1 can be accessed at the following addresses:

	DP Offset A ^a	SELECT.DPBANKSEL
BASEPTR0	0x0	0x2
BASEPTR1	0x0	0x3

a. Bits[1:0] of the register address are always 0b00.

B2.2.3 CTRL/STAT, Control/Status register

The CTRL/STAT characteristics are:

Purpose

CTRL/STAT is a DP architecture register that is used to control and obtains status information about the DP.

Usage Constraints

Access to CTRL/STAT and its value after a powerup reset are defined for each field individually, as shown in the table. Some of fields are RO, meaning they ignore writes. See the field descriptions for detailed information.

Field	Access	Value after powerup reset
CSYSPWRUPACK	RO	
CSYSPWRUPREQ	RW	0b0
CDBGPWRUPACK	RO	
CDBGPWRUPREQ	RW	0b0
CDBGRSTACK	RO	
CDBGRSTREQ	IMPLEMENTATION DEFINED, RW, or RAZ/WI. See <i>Debug reset control behavior</i> on page B2-87.	0b0
ERRMODE	RW	
TRNCNT ^a	RW	UNKNOWN
MASKLANE ^a	RW	UNKNOWN
WDATAERR	DATA LINK DEFINED, RES0 or RO/WI. See field description.	0b0
READOK	DATA LINK DEFINED, RES0 or RO/WI. See field description.	0b0
STICKYERR	DATA LINK DEFINED, R/W1C or RO/WI. See field description.	0b0
STICKYCMP ^a	DATA LINK DEFINED, R/W1C or RO/WI. See field description.	0b0
TRNMODE ^a	RW	UNKNOWN
STICKYORUN	DATA LINK DEFINED, R/W1C or RO/WI. See field description.	
ORUNDETECT	RW	0b0

- a. MASKLANE, TRNCNT, TRNMODE, and STICKYCMP are not supported in MINDP configuration. In MINDP configuration, the effect of writing a value other than zero to TRNCNT, TRNMODE, or STICKYCMP is UNPREDICTABLE.

Configurations

Included in all implementations.

Attributes

A 32-bit read/write register.

Field descriptions

The CTRL/STAT bit assignments are:

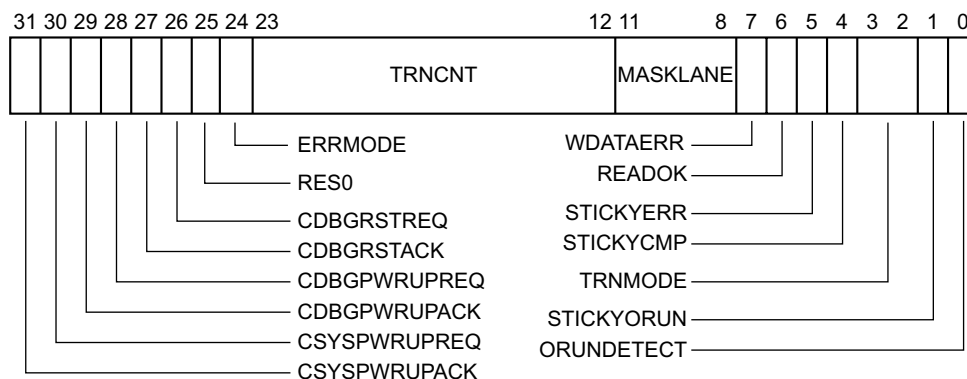

CSYSPWRUPACK, bit[31]

System powerup acknowledge. Indicates the status of the CSYSPWRUPACK signal. See [Power control requirements and operation on page B2-84](#).

This bit is RO, meaning it ignores writes.

CSYSPWRUPREQ, bit[30]

System powerup request. This bit controls the CSYSPWRUPREQ signal. See [Power control requirements and operation on page B2-84](#).

After a powerup reset, this bit is 0b0.

CDBGPWRUPACK, bit[29]

Debug powerup acknowledge. Indicates the status of the CDBGPWRUPACK signal. See [Power control requirements and operation on page B2-84](#).

This bit is RO, meaning it ignores writes.

CDBGPWRUPREQ, bit[28]

Debug powerup request. This bit controls the CDBGPWRUPREQ signal. See [Power control requirements and operation on page B2-84](#).

After a powerup reset, this bit is 0b0.

CDBGRESTACK, bit[27]

Debug reset acknowledge. Indicates the status of the CDBGRESTACK signal. See [Debug reset control behavior on page B2-87](#).

This bit is RO, meaning it ignores writes.

CDBGRESTREQ, bit[26]

Debug reset request. This bit controls the CDBGRESTREQ signal. See [Debug reset control behavior on page B2-87](#).

It is IMPLEMENTATION DEFINED whether this bit is RW or RAZ/WI. See [Debug reset control behavior on page B2-87](#).

After a powerup reset, this bit is 0b0.

Bit[25]

Reserved, RES0.

ERRMODE, bit[24]

Error mode. Indicates the reset behavior of the [CTRL/STAT.STICKYERR](#) field. See also the description of the STICKYERR field.

This field is defined for DPv3 and later. In earlier DP architectures, this field is RES0.

ERRMODE can have one of the following values:

0b0 Errors on AP transactions set [CTRL/STAT.STICKYERR](#) and [CTRL/STAT.STICKYERR](#) remains set until explicitly cleared.

0b1 Errors on AP transactions set [CTRL/STAT.STICKYERR](#), and [CTRL/STAT.STICKYERR](#) is cleared when a FAULT response is output.

If ERRMODE is 0b1, an error that occurs on an AP transaction might be reported to the debugger via a FAULT response, but does not require the debugger to explicitly clear [CTRL/STAT.STICKYERR](#). The JTAG-DP or SW-DP transaction that caused the FAULT response does not succeed, and [CTRL/STAT.STICKYERR](#) is cleared to 0b0, allowing future transactions to be attempted.

After a powerup reset, the value of this field is 0b0.

TRNCNT, bits[23:12]

Transaction counter. See [The transaction counter on page B1-45](#).

After a powerup reset, the value of this field is UNKNOWN.

————— Note —————

It is IMPLEMENTATION DEFINED whether this field is implemented.

TRNCNT is not supported in MINDP configuration. In MINDP configuration, the effect of writing a value other than zero to TRNCNT or TRNMODE is UNPREDICTABLE. See also [MINDP, Minimal DP extension on page B1-42](#).

MASKLANE, bits[11:8]

For pushed operations, the DP performs a byte-by-byte comparison of the word that is supplied in an AP write transaction with the current word at the target AP address. The MASKLANE field is used to select the bytes to be included in this comparison. For more information about pushed operations, see [Pushed-compare and pushed-verify operations on page B1-46](#).

Each of the 4 bits of the MASKLANE field corresponds to one of the four bytes of the words to be compared. Therefore, each bit is said to control one byte lane of the compare operation.

[Table B2-4](#) shows how the bits of MASKLANE control the comparison masking.

Table B2-4 Control of pushed operation comparisons by MASKLANE

MASKLANE	Effect	Bits included in comparisons ^a
0b1xxx	Include byte lane 3 in comparisons.	Bits[31:24].
0bx1xx	Include byte lane 2 in comparisons.	Bits[23:16].
0bxx1x	Include byte lane 1 in comparisons.	Bits[15:8].
0bxxx1	Include byte lane 0 in comparisons.	Bits[7:0].

- a. Whether other bits are included is determined by the other bits of MASKLANE:
To compare the whole word, MASKLANE is set to 0b1111 to include all byte lanes.
If a MASKLANE bit is 0b0, the corresponding byte lane is excluded from the comparison.

Note

The following applies to the MASKLANE field:

- MASKLANE is only relevant if the Transfer Mode field TRNMODE is 0b01, for pushed-verify operations, or 0b10, for pushed-compare operations. See the description of the TRNMODE field and [Pushed-compare and pushed-verify operations on page B1-46](#).
 - It is IMPLEMENTATION DEFINED whether MASKLANE is implemented. See [MINDP, Minimal DP extension on page B1-42](#).
 - After a powerup reset, the value of MASKLANE is UNKNOWN.
-

WDATAERR, bit[7]

This bit is set to 0b1 if one of the following Write Data Error occurs:

- A parity or framing error on the data phase of a write.
- A write that has been accepted by the DP is then discarded without being submitted to the AP.

For more information, see [Sticky flags and DP error responses on page B1-43](#).

Access to and how to clear this field are DATA LINK DEFINED:

JTAG-DP, all implementations

Access is reserved, RES0.

SW-DP, all implementations

- Access is RO/WI.
- To clear WDATAERR to 0b0, write 0b1 to the [ABORT.WDERRCLR](#) field in the [ABORT](#) register. A single write of the [ABORT](#) register can be used to clear multiple flags if necessary.

After clearing the WDATAERR flag, the corrupted data is typically resent.

After a powerup reset, WDATAERR is 0b0.

READOK, bit[6]

This bit is DATA LINK DEFINED:

- On JTAG-DP, the bit is reserved, RES0.
- On SW-DP, access is RO/WI.

If the response to the previous AP read or RDBUFF read was OK, the bit is set to 0b1. If the response was not OK, it is cleared to 0b0.

This flag always indicates the response to the last AP read access. See [Protocol error response on page B4-122](#).

After a powerup reset, this bit is 0b0.

Note

This field is defined for DPv1 and higher only.

STICKYERR, bit[5]

This bit is set to 0b1 if an error is returned by an AP transaction. See [Sticky flags and DP error responses on page B1-43](#).

Access to and how to clear this field are DATA LINK DEFINED:

JTAG-DP, all implementations

- Access is R/W1C.
- To clear STICKYERR to 0b0, write 0b1 to it, which signals the DP to clear the flag and set it to 0b0. A single write of the [CTRL/STAT](#) register can be used to clear multiple flags if necessary. STICKYERR can also be cleared by writing 0b1 to the [ABORT.STKERRCLR](#) field.

SW-DP, all implementations

- Access is RO/WI.
- To clear STICKYERR to 0b0, write 0b1 to the [ABORT.STKERRCLR](#) field in the [ABORT](#) register. A single write of the [ABORT](#) register can be used to clear multiple flags if necessary.

After clearing [CTRL/STAT.STICKYERR](#), you must find the location where the error that caused the flag to be set occurred.

After a powerup reset, this bit is 0b0.

STICKYCMP, bit[4]

This bit is set to 0b1 when a mismatch occurs during a pushed-compare operation or a match occurs during a pushed-verify operation. See [Pushed-compare and pushed-verify operations on page B1-46](#).

It is IMPLEMENTATION DEFINED whether this field is implemented. See [MINDP, Minimal DP extension on page B1-42](#).

Access to and how to clear this field are DATA LINK DEFINED:

JTAG-DP, all implementations

- Access is R/WIC.
- To clear STICKYCMP to 0b0, write 0b1 to it, which signals the DP to clear the flag and set it to 0b0. A single write of the [CTRL/STAT](#) register can be used to clear multiple flags if necessary. STICKYCMP can also be cleared by writing 0b1 to the [ABORT.STKERRCLR](#) field.

SW-DP, all implementations

- Access is RO/WI.
- To clear STICKYCMP to 0b0, write 0b1 to the [ABORT.STKCMPLR](#) field in the [ABORT](#) register. A single write of the [ABORT](#) register can be used to clear multiple flags if necessary.

After clearing [CTRL/STAT.STICKYCMP](#), you must retrieve the value of the transaction counter to find the location where the error that caused the flag to be set occurred.

After a powerup reset, this bit is 0b0.

TRNMODE, bits[3:2]

This field sets the transfer mode for AP operations.

In normal operation, AP transactions are passed to the AP for processing, as described in [Using the AP to access debug resources on page A1-31](#).

In pushed-verify and pushed-compare operations, the DP compares the value that is supplied in an AP write transaction with the value held in the target AP address. The AP write transaction generates a read access to the debug memory system as described in [Pushed-compare and pushed-verify operations on page B1-46](#).

TRNMODE can have one of the following values:

0b00	Normal operation.
0b01	Pushed-verify mode.
0b10	Pushed-compare mode.
0b11	Reserved.

After a powerup reset, the value of this field is UNKNOWN.

———— Note —————

It is IMPLEMENTATION DEFINED whether this field is implemented.

TRNMODE is not supported in MINDP configuration. In MINDP configuration, the effect of writing a value other than zero to TRNCNT or TRNMODE is UNPREDICTABLE. See also [MINDP, Minimal DP extension on page B1-42](#).

STICKYORUN, bit[1]

If overrun detection is enabled, this bit is set to 0b1 when an overrun occurs. See bit[0] of this register for details of enabling overrun detection.

Access to and how to clear this field are DATA LINK DEFINED:

JTAG-DP, all implementations

- Access is R/W1C.
- To clear STICKYORUN to 0b0, write 0b1 to it, which signals the DP to clear the flag and set it to 0b0. A single write of the CTRL/STAT register can be used to clear multiple flags if necessary. STICKYORUN can also be cleared by writing 0b1 to the ABORT.STKERRCLR field.

SW-DP, all implementations

- Access is RO/WI.
- To clear STICKYORUN to 0b0, write 0b1 to the ABORT.ORUNERRCLR field in the ABORT register. A single write of the ABORT register can be used to clear multiple flags if necessary.

After clearing CTRL/STAT.STICKYORUN, you must find out which DP or AP transaction initiated the overrun that caused the flag to be set, and repeat the transactions for that DP or AP from the transaction pointed to by the transaction counter.

After a powerup reset, this bit is 0b0.

ORUNDETECT, bit[0]

This bit can have one of the following values:

- 0b0 Overrun detection is disabled.
- 0b1 Overrun detection is enabled.

For more information about overrun detection, see [Sticky flags and DP error responses on page B1-43](#).

After a powerup reset, this bit is 0b0.

Accessing CTRL/STAT

CTRL/STAT can be accessed at the following address:

DP Offset A ^a	SELECT.DPBANKSEL
0x4	0x0

a. Bits[1:0] of the register address are always 0b00.

B2.2.4 DLCR, Data Link Control Register

The **DLCR** characteristics are:

Purpose

Controls the operating mode of the Data Link.

Usage Constraints

DLCR is DATA LINK DEFINED:

- For a JTAG DP, the **DLCR** register is RES0.
- For an SW-DP, the **DLCR** register has the fields that are described in *Field descriptions on page B2-65*.

DLCR is accessible as follows:

Default

RW

Configurations

Included in all implementations.

Attributes A 32-bit DATA LINK DEFINED DP architecture register.

Field descriptions

The **DLCR** bit assignments for an SW-DP are:

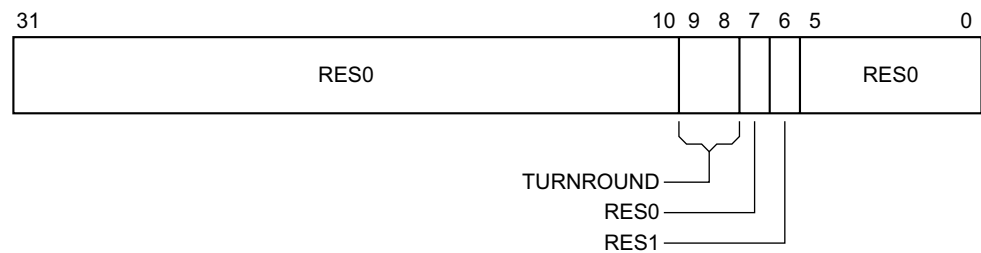

Bits[31:10]

Reserved, RES0.

TURNROUND, bits[9:8]

For an SW-DP, this field defines the turnaround tristate period. For details about line turnaround, see *Line turnaround on page B4-115*. *Table B2-5* shows the permitted values of this field, and their meanings.

Table B2-5 Turnaround tristate period field, TURNROUND, bit definitions

DLCR.TURNROUND	Turnaround tristate period
0b00	1 data period ^a .
0b01	2 data periods ^a .
0b10	3 data periods ^a .
0b11	4 data periods ^a .

a. A *data period* is the period of a single data bit on the SWD interface.

After a powerup or line reset, this field is 0b00.

Note

Support for varying the turnaround tristate period is IMPLEMENTATION DEFINED. An implementation that does not support variable turnaround must treat writing a value other than 0b00 to the TURNROUND field as an immediate protocol error.

Bit[7]

Reserved, RES0.

Bit[6]

Reserved, RES1.

Bits[5:0]

Reserved, RES0.

Accessing DLCR

DLCR can be accessed at the following address:

DP Offset A ^a	SELECT.DPBANKSEL
0x4	0x1

a. Bits[1:0] of the register address are always 0b00.

B2.2.5 DLPIDR, Data Link Protocol Identification Register

The DLPIDR characteristics are:

Purpose DLPIDR provides protocol version information.

Usage Constraints

DLPIDR is accessible as follows:

Default
RO

Configurations

Included in all implementations.

SW-DP configurations

An SWD Port must implement at least SWD protocol version 2.

JTAG-DP configurations

A JTAG Port must implement at least JTAG protocol version 1.

Attributes

A 32-bit DATA LINK DEFINED register.

Field descriptions

For DPs that implement the [DLPIDR](#), the bit assignments are:

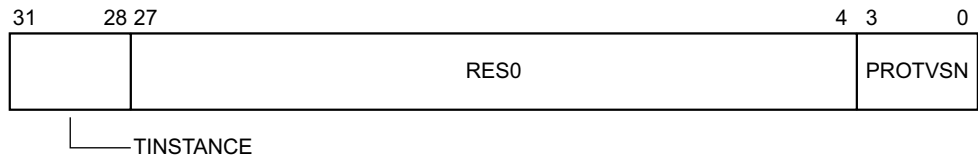

TINSTANCE, bits[31:28]

IMPLEMENTATION DEFINED. Defines an instance number for this device. This value must be unique for all devices with identical [TARGETID.TPARTNO](#) and [TARGETID.TDESIGNER](#) fields that are connected together in a multi-drop system.

Bits[27:4]

RES0.

PROTVSN, bits[3:0]

Defines the SWD or JTAG protocol version that is implemented.

For a SW-DP, this field can have one of the following values:

0x1 SWD protocol version 2. Adds support for multidrop extensions. See [Chapter B4 The Serial Wire Debug Port](#).

Other Reserved.

For a JTAG-DP, this field can have one of the following values:

0x0 JTAG-DP protocol version 0.

0x1 JTAG-DP protocol version 1.

Other Reserved.

Accessing DLPIDR

[DLPIDR](#) can be accessed at the following address:

DP Offset A ^a	SELECT.DPBANKSEL
0x4	0x3

a. Bits[1:0] of the register address are always 0b00.

B2.2.6 DPIDR, Debug Port Identification Register

The [DPIDR](#) characteristics are:

Purpose

[DPIDR](#) provides information about the Debug Port.

Usage Constraints

[DPIDR](#) is accessible as follows:

Default
RO

Configurations

Included in all implementations.

Note

In DPv0, the [DPIDR](#) is reserved and accesses are UNPREDICTABLE.

In all DP architecture versions, a JTAG-DP implementation must implement the IDCODE instruction and IDCODE scan-chain. The architecture does not require that the TAP [IDCODE](#) register value and the [DPIDR](#) value are the same.

Attributes A 32-bit DP architecture register.

Field descriptions

The [DPIDR](#) bit assignments are:

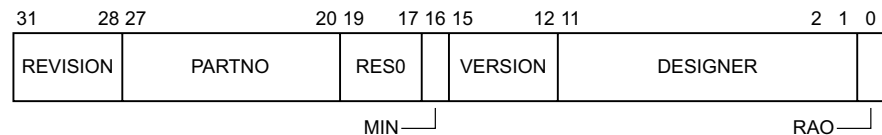

REVISION, bits[31:28]

Revision code. The meaning of this field is IMPLEMENTATION DEFINED.

PARTNO, bits[27:20]

Part Number for the DP. This value is provided by the designer of the DP and must not be changed.

Bits[19:17] Reserved, RES0.

MIN, bit[16] MINDP functions implemented:

- 0b0 Transaction counter, Pushed-verify, and Pushed-find operations are implemented.
- 0b1 Transaction counter, Pushed-verify, and Pushed-find operations are not implemented.

VERSION, bits[15:12]

Version of the DP architecture implemented. Permitted values are:

- 0x0 Reserved. Implementations of DPv0 do not implement [DPIDR](#).
- 0x1 DPv1 is implemented.
- 0x2 DPv2 is implemented.
- 0x3 DPv3 is implemented.

All remaining values are reserved.

DESIGNER, bits[11:1]

Code that identifies the designer of the DP.

This field indicates the designer of the DP and not the implementer, except where the two are the same. To obtain a number, or to see the assignment of these codes, contact JEDEC <http://www.jedec.org>.

A JEDEC code takes the following form:

- A sequence of zero or more numbers, all having the value 0x7F.
- A following 8-bit number, that is not 0x7F, and where bit[7] is an odd parity bit. For example, Arm Limited is assigned the code 0x7F 0x7F 0x7F 0x7F 0x3B.

The encoding that is used in the DPIDR is as follows:

- The JEP106 continuation code, DPIDR bits[11:8], is the number of times that 0x7F appears before the final number. For example, for Arm Limited this field is 0x4.
- The JEP106 identification code, IDR bits[7:1], equals bits[6:0] of the final number of the JEDEC code. For example, for Arm Limited this field is 0x3B.

Bit[0] RAO.

Accessing DPIDR

DPIDR can be accessed at the following address:

DP Offset A ^a	SELECT.DPBANKSEL
0x0	0x0

a. Bits[1:0] of the register address are always 0b00.

B2.2.7 DPIDR1, Debug Port Identification Register 1

The [DPIDR1](#) characteristics are:

Purpose

[DPIDR1](#) provides information about the Debug Port.

Usage Constraints

Reads of [DPIDR1](#) must be processed immediately and must not issue a WAIT response.

[DPIDR1](#) is accessible as follows:

Default
RO

Configurations

Included in all implementations.

Attributes

A 32-bit DP architecture register.

Field descriptions

The [DPIDR1](#) bit assignments are:

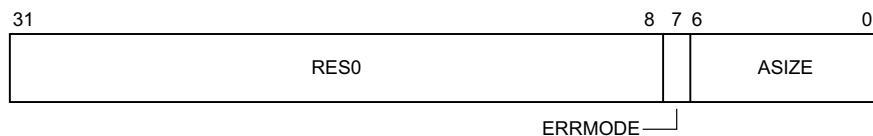

Bits[31:8]

RES0.

ERRMODE, bit[7]

Error reporting mode support. This field can have one of the following values:

0b0 [CTRL/STAT.ERRMODE](#) is not implemented.

0b1 [CTRL/STAT.ERRMODE](#) is implemented.

ASIZE, bits[6:0]

Address size. This field selects the size of the addresses in the [SELECT](#) on page B2-76, [SELECT1](#) on page B2-76, [BASEPTR0](#) on page B2-55, and [BASEPTR1](#) on page B2-55 registers, and can have one of the following values:

0x0C 12-bit address.

0x14 20-bit address.

0x20 32-bit address.

0x28 40-bit address.

0x30 48-bit address.

0x34 52-bit address.

All remaining values are reserved.

Accessing DPIDR1

DPIDR1 can be accessed at the following address:

DP Offset A ^a	SELECT.DPBANKSEL
0x0	0x1

- a. Bits[1:0] of the register address are always 0b00.

B2.2.8 EVENTSTAT, Event Status register

The **EVENTSTAT** register characteristics are:

Purpose

EVENTSTAT is used by the system to signal an event to the external debugger. The nature of the event is IMPLEMENTATION DEFINED.

Arm recommends connecting **EVENTSTAT** to one of the following:

- An output trigger of a CoreSight *Cross-Trigger Interface (CTI)* with software acknowledge.
- An output from a uniprocessor system that indicates whether the processor is halted:
 - For Armv6-M, Armv7-M, and Armv8-M processors, the recommended **HALTED** signal.
 - For all other Arm architecture processors, the recommended **DBGACK** signal.

Usage Constraints

EVENTSTAT is accessible as follows:

Default

RO

Configurations

Included in all implementations.

Attributes

A 32-bit RO register.

Field descriptions

The **EVENTSTAT** bit assignments are:

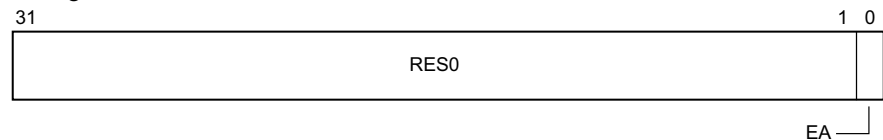

Bits[31:1] Reserved, RES0.

EA, bit[0] If an event is implemented, this field is the event status flag. Valid values for the flag are:

0b0 An event requires attention.

0b1 There is no event requiring attention.

If no event is implemented, this field is RAZ.

———— **Note** ————

The status of the event is inverted in the register, and when debugging an implementation that does not implement an event, debuggers interpret a value of zero as an event requiring attention, and poll other registers to detect the status of the system.

Accessing **EVENTSTAT**

EVENTSTAT can be accessed at the following address:

DP Offset A ^a	SELECT.DPBANKSEL
0x4	0x4

- a. Bits[1:0] of the register address are always 0b00.

B2.2.9 RDBUFF, Read Buffer register

The **RDBUFF** register characteristics are:

Purpose

The purpose and behavior of **RDBUFF** is DATA LINK DEFINED:

JTAG-DP The Read Buffer is architecturally defined to provide a DP read operation that does not have any side effects. This definition allows a debugger to insert a DP read of **RDBUFF** at the end of a sequence of operations, to return the final AP Read Result and ACK values.

SW-DP On an SW-DP, the Read Buffer presents data that was captured during the previous AP read, enabling repeatedly returning the value without generating a new AP access.

Note

After reading the DP Read Buffer, its contents are no longer valid. The result of a second read of the DP Read Buffer is UNKNOWN.

If the value is required from an AP register read, that read must be followed by one of:

- A second AP register access, with the appropriate AP selected as the current AP.
- A read of the DP Read Buffer.

The second access to either the AP or the DP stalls until the result of the original AP read is available.

Usage Constraints

RDBUFF is accessible as follows:

Default

RO

Configurations

Included in all implementations.

Attributes

A 32-bit read-only buffer.

Field descriptions

The **RDBUFF** bit assignments are:

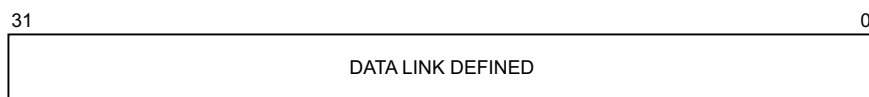

Bits[31:0] DATA LINK DEFINED:

JTAG-DP RAZ/WI

SW-DP Data for previous AP read.

Accessing RDBUFF

RDBUFF can be accessed at the following address:

DP Offset A ^a	SELECT.DPBANKSEL
0xC	x

- a. Bits[1:0] of the register address are always 0b00.

B2.2.10 RESEND, Read Resend register

The **RESEND** register characteristics are:

Purpose

Performing a read to **RESEND** does not capture new data from the AP, but returns the value that was returned by the last AP read or DP **RDBUFF** read.

RESEND enables the debugger to recover read data from a corrupted SW-DP transfer without having to re-issue the original read request, or generate a new access to the connected debug memory system.

RESEND can be accessed multiple times, and always returns the same value until a new access is made to an AP register or the DP **RDBUFF** register.

Usage Constraints

Arm recommends that debuggers only access **RESEND** when a failed read has been indicated by the SW-DP, and at no other time. The reason for this is that, if an implementation cannot resend the information, it is permitted to treat reads of **RESEND** as a protocol error.

RESEND is accessible as follows:

Default

RO

Configurations

Included in all implementations.

Attributes

A 32-bit read-only DP architecture register.

The **RESEND** register is:

- A read-only register.
- Accessed by a read of offset 0x8 in the DP register map.
- DATA LINK DEFINED:

JTAG-DP The register is reserved, any access is UNPREDICTABLE.

SW-DP The value that was returned by the last AP read or DP **RDBUFF** read.

Field descriptions

The **RESEND** bit assignments are:

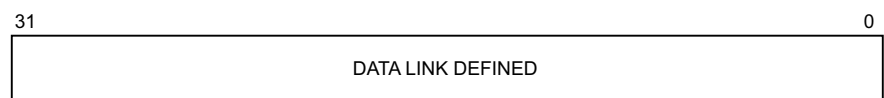

Bits[31:0] DATA LINK DEFINED:

JTAG-DP The register is reserved, any access is UNPREDICTABLE.

SW-DP Data for previous AP read.

Accessing RESEND

RESEND can be accessed at the following address:

DP Offset A ^a	SELECT.DPBANKSEL
0x8	x

a. Bits[1:0] of the register address are always 0b00.

B2.2.11 SELECT-SELECT1, AP Select registers

The [SELECT-SELECT1](#) characteristics are:

Purpose

The [SELECT-SELECT1](#) registers:

- Select an AP and the active register banks within that AP.
- Select the DP address bank.

Usage Constraints

[SELECT-SELECT1](#) are accessible as follows:

Default
WO

Configurations

Included in all implementations.

Attributes

Two 32-bit DP architecture registers.

Field descriptions

The [SELECT-SELECT1](#) bit assignments are:

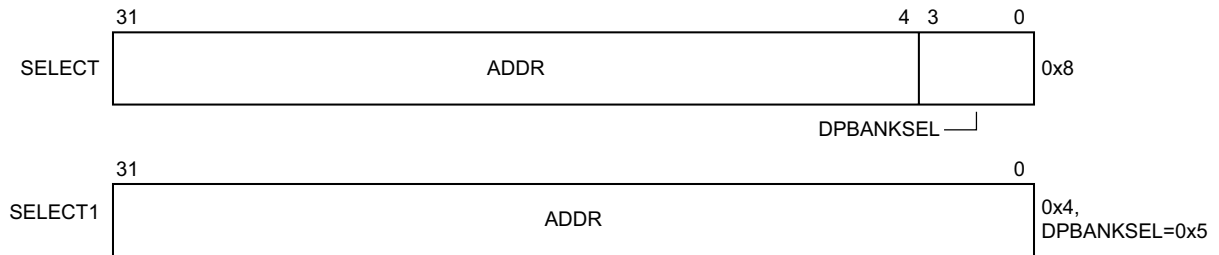

ADDR, SELECT1 bits[31:0] : SELECT bits[31:4]

Address output bits[63:4], formed by concatenating bits[31:0] of [SELECT1](#) with bits[31:4] of [SELECT](#). The ADDR field selects a four-word bank of system locations to access. Bits[3:2] of the address, that are used to select a specific register in a bank, are provided with APACC transactions. Bits[1:0] are always 0b00.

After a powerup reset or an SWD line reset, the value of this field is UNKNOWN.

DPBANKSEL, bit[3:0]

DP address bank select.

The behavior of `SELECT.DPBANKSEL` depends on the DP version. In DPv3, the `SELECT.DPBANKSEL` field controls which DP register is selected at addresses `0x0` and `0x4`, and Table B2-6 shows the permitted values of this field.

Table B2-6 DPBANKSEL DP register allocation in DPv3

DPBANKSEL	DP register at address 0x0	DP register at address 0x4
0x0	DPIDR	CTRL/STAT
0x1	DPIDR1	DLCR
0x2	BASEPTR0	TARGETID
0x3	BASEPTR1	DLPIDR
0x4	Reserved, RES0.	EVENTSTAT
0x5		SELECT1
0x6-0xF		Reserved, RES0.

All other values of `SELECT.DPBANKSEL` are reserved. If the field is set to a reserved value, accesses to DP register `0x0` or `0x4` are RES0.

After a powerup reset, this field is `0x0`.

After an SWD line reset, this field must be reset to `0x0`.

Note

Some earlier ADI revisions have described `DPBANKSEL` as a single-bit field called `CTRSEL`, which is defined only for SW-DP.

Accessing SELECT-SELECT1

`SELECT-SELECT1` can be accessed at the following addresses:

	Offset A ^a	DPBANKSEL
SELECT	0x8	Not applicable
SELECT1	0x4	0x5

a. Bits[1:0] of the register address are always `0b00`.

B2.2.12 TARGETID, Target Identification register

The TARGETID register characteristics are:

Purpose

TARGETID provides information about the target when the host is connected to a single device.

Usage Constraints

TARGETID is accessible as follows:

Default

RO

Configurations

Included in all implementations.

Attributes

A 32-bit read-only register.

Field Descriptions

The TARGETID bit assignments are:

31	28 27	12 11	1 0
TREVISION	TPARTNO	TDESIGNER	1

TREVISION, bits[31:28]

Target revision.

TPARTNO, bits[27:12]

IMPLEMENTATION DEFINED. The value is assigned by the designer of the part. The value must be unique to the part.

TDESIGNER, bits[11:1]

IMPLEMENTATION DEFINED.

This field indicates the designer of the part and not the implementer, except where the two are the same.

Designers must insert their JEDEC-assigned code here.

———— Note —————

The Arm JEP106 value is not shown for the TDESIGNER field. Arm might design a DP containing the TARGETID register, but typically, the designer of the part is another designer who creates a part around the licensed Arm IP. The designer who creates the part is referenced in the TPARTNO field. If the designer of the part is Arm, the value of this field is 0x23B.

To obtain a number, or to see the assignment of these codes, contact JEDEC at <http://www.jedec.org>.

A JEP106 code takes the following form:

- A sequence of zero or more numbers, all having the value 0x7F.
- A following 8-bit number, that is not 0x7F, and where bit[7] is an odd parity bit. For example, Arm Limited is assigned the code 0x7F 0x7F 0x7F 0x7F 0x3B.

The encoding that is used in **TARGETID** is as follows:

- The JEP106 continuation code, **TARGETID** bits[11:8], is the number of times that 0x7F appears before the final number.
- The JEP106 identification code, **TARGETID** bits[7:1], equals bits[6:0] of the final number of the JEDEC code.

For example, for Arm Limited this field is the concatenation of 0x4, which represents the number of times that 0x7F appears, and 0x3B, the Arm JEP106 code, resulting in a value of 0x23B.

Bit[0] RAO.

Accessing **TARGETID**

TARGETID can be accessed at the following address:

DP Offset A ^a	SELECT.DPBANKSEL
0x4	0x2

a. Bits[1:0] of the register address are always 0b00.

B2.2.13 TARGETSEL, Target Selection register

The [TARGETSEL](#) register characteristics are:

Purpose

[TARGETSEL](#) selects the target device in an SWD multi-drop system.

On a write to [TARGETSEL](#) immediately following a line reset sequence, the target is selected if both the following conditions are met:

- Bits[31:28] match bits[31:28] in the [DLPIDR](#).
- Bits[27:0] match bits[27:0] in the [TARGETID](#) register.

Writing any other value deselects the target. Debug tools must write 0xFFFFFFFF to deselect all targets. 0xFFFFFFFF is an invalid [TARGETID](#) value. All other invalid [TARGETID](#) values are reserved.

During the response phase of a write to the [TARGETSEL](#) register, the target does not drive the line. See [Sticky flags and DP error responses on page B1-43](#) for more information.

Usage Constraints

[TARGETSEL](#) is DATA LINK DEFINED:

JTAG-DP The register is reserved, any access is UNPREDICTABLE.

SW-DP If SWD protocol version 2 is implemented, the register is implemented.

[TARGETSEL](#) is accessible as follows:

SW-DP	JTAG-DP
WO	UNPREDICTABLE

Configurations

Included in all implementations.

Attributes

A 32-bit DP architecture register.

Field descriptions

For an SW-DP, the [TARGETSEL](#) bit assignments are:

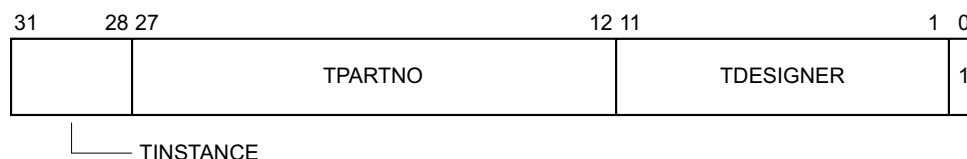

TINSTANCE, bits[31:28]

IMPLEMENTATION DEFINED. The instance number for this device. See [DLPIDR](#).

TPARTNO, bits[27:12]

IMPLEMENTATION DEFINED. The value that is assigned by the designer of the part. See [TARGETID](#).

TDESIGNER, bits[11:1]

IMPLEMENTATION DEFINED. The 11-bit code that is formed from the JEDEC JEP106 continuation code and identity code. See [TARGETID](#).

Bit[0]

SBO.

Accessing TARGETSEL

TARGETSEL can be accessed at the following address:

DP Offset A ^a	SELECT.DPBANKSEL
0xC	x

- a. Bits[1:0] of the register address are always 0b00.

B2.3 System and debug power control behavior

This section gives detailed information about system and debug power.

B2.3.1 The ADI power domains model

The ADI supports multiple power domains, which provide support for debug components that can be powered down.

Three power domains are modeled:

Always-on power domain

Power domain that must be powered up for the debugger to connect to the device.

System power domain

Power domains that include system components.

Debug power domain

Power domain that includes the entire debug subsystem.

The system and debug power domains can be subdivided if necessary. However, to define a simple debug interface, the device must be partitioned into system and debug power domains at the top level. Any finer-grained control is outside the scope of this model.

In most situations, debuggers power up the complete SoC. However, if a debugger is investigating an energy management issue, it might want to power up only the debug domain. To achieve this goal, SoC designers might want to map the power controller into a bus segment that the ADI can access when only the debug power domain is powered up.

When using an ADI, for the debug process to work correctly, systems must not remove power from the DP during a debug session. If power is removed, the DP controller state is lost. However, the ADI is designed to permit the rest of the ADI and the system to be powered down and debugged while maintaining power to the DP.

The DP registers reside in the always-on power domain, on the external interface side of the DP. Therefore, they can always be driven, enabling powerup requests to be made to a system power controller. The power and reset control bits are part of the DP **CTRL/STAT** register. See [Debug reset control behavior on page B2-87](#) for more information about the reset control bits in this register.

ADiv6 defines two pairs of power control signals:

- **CDBGPWRUPREQ** and **CDBGPWRUPACK**.
- **CSYSPWRUPREQ** and **CSYSPWRUPACK**.

[Table B2-7](#) summarizes the programmers' model for the power control signal pairs.

Table B2-7 Debug Port programmers' model

Signal	Programmers' model
CDBGPWRUPREQ	Bit[28] of the CTRL/STAT register
CDBGPWRUPACK	Bit[29] of the CTRL/STAT register
CSYSPWRUPREQ	Bit[30] of the CTRL/STAT register
CSYSPWRUPACK	Bit[31] of the CTRL/STAT register

These signals are expected to provide requests to the system power and clock controller. The following sections describe these signal pairs.

CDBGPWRUPREQ and CDBGPWRUPACK

CDBGPWRUPREQ is the signal from the debug interface to the power controller. This signal requests the system power controller to fully power up and ensure the clocks are available in the debug power domain.

CDBGPWRUPACK is the signal from the power controller to the debug interface. When **CDBGPWRUPREQ** is asserted, the power controller powers up the debug power domain and then asserts **CDBGPWRUPACK** to acknowledge that it has responded to the request.

It is IMPLEMENTATION DEFINED which components are in the debug power domain that is controlled by **CDBGPWRUPREQ**. This domain might include all debug components in the system, or it might be limited to exclude components that have extra levels of power control, for example. The **CDBGPWRUPREQ** signal indicates that the debugger requires the debug resources of these components to be communicative. Communicative means that the debugger can access at least enough registers of the debug resource for it to determine the state of the resource. Whether the resource is active is IMPLEMENTATION DEFINED. The power and clock controller must power up and run the clocks of as many domains as necessary to comply with this request from the debugger for the resources to be communicative.

The power and clock controller must honor **CDBGPWRUPREQ** for as long as it is asserted. For example, if a component in a debug power domain requests to be powered down, the request must be emulated for non-debug logic within that power domain, including all components with a single shared domain.

If some debug resources of a component are not in the debug power domain, then at least the minimal debug interface of the component must be powered up. If the following requirements are met, power can be removed from the remainder of the component:

- There is some means to save and restore the state of the debug resources.
- The debugger can communicate with the debug resources when the remainder of the component is not powered.

The means to save and restore the values that are held in these resources might include software solutions. If the debug resources do lose their value when power is removed from the remainder of the component, then the debug interface must include means for the debugger to discover that the programmed values have been lost.

CDBGPWRUPACK is the acknowledge signal for the **CDBGPWRUPREQ** request signal. **CDBGPWRUPACK** must be asserted for as long as **CDBGPWRUPREQ** is asserted. See [Powerup request and acknowledgment timing on page B2-84](#).

CSYSPWRUPREQ and CSYSPWRUPACK

CSYSPWRUPREQ is the signal from the debug interface to the power controller. This signal requests the system power controller to fully power up and ensure the clocks are available in the system power domain.

CSYSPWRUPACK is the signal from the power controller to the debug interface. When **CSYSPWRUPREQ** is asserted, the power controller powers up the system power domain and then asserts **CSYSPWRUPACK** to acknowledge that it has responded to the request.

It is IMPLEMENTATION DEFINED which components are in the debug power domain that is controlled by **CDBGPWRUPREQ**. This domain might include all debug components in the system, or might be limited, for example to exclude components that have extra levels of power control, such as processors that implement independent Core Powerup Request controls.

The **CSYSPWRUPREQ** signal indicates that the debugger requires all debug resources of these components to be active. Active means that the debug resource can perform its debug function. An active resource is also communicative.

The power and clock controller must honor **CSYSPWRUPREQ** for as long as it is asserted.

CSYSPWRUPREQ has no effect on debug components that are controlled by **CDBGPWRUPREQ**, because those components have no debug logic in the system power domain. However, for components where some debug resources are in the system power domain that is controlled by **CSYSPWRUPREQ**, the request must be emulated for non-debug logic within that power domain.

CSYSPWRUPACK is the acknowledge signal for the **CSYSPWRUPREQ** request signal. **CSYSPWRUPACK** must be asserted for as long as **CSYSPWRUPREQ** is asserted. See [Powerup request and acknowledgment timing on page B2-84](#).

When **CSYSPWRUPREQ** is asserted by the debugger, **CDBGPWRUPREQ** must also be asserted.

B2.3.2 Power control requirements and operation

This section applies to both the system and the debug domain, and uses the following notation:

- **CxxxPWRUPREQ** refers to either **CSYSPWRUPREQ** or **CDBGPWRUPREQ**.
- **CxxxPWRUPACK** refers to either **CSYSPWRUPACK** or **CDBGPWRUPACK**.

All signals that are described in this section are active-high. Therefore, assert denotes taking the signal HIGH, and deassert denotes taking the signal LOW.

The rules for the operation of powerup requests and acknowledgments are:

- The debugger must not set **CTRL/STAT.CSYSPWRUPREQ** to 0b1 and **CTRL/STAT.CDBGPWRUPREQ** to 0b0 at the same time. The response to this combination of requests is UNPREDICTABLE.
- To initiate powerup, the DP must assert **CxxxPWRUPREQ**.
 - If the corresponding power domain is powered down or in a low-power retention state, the power controller must power up the domain when it detects that **CxxxPWRUPREQ** is asserted. After the domain is powered up, the controller must assert **CxxxPWRUPACK**.
 - If the corresponding power domain is already powered up when the power controller detects that **CxxxPWRUPREQ** is asserted, the controller must still respond by asserting **CxxxPWRUPACK**, even though it does not affect the power domain.
- Arm strongly recommends that tools only initiate an AP transfer when **CDBGPWRUPREQ** and **CDBGPWRUPACK** are asserted. If **CDBGPWRUPREQ** or **CDBGPWRUPACK** is LOW, any AP transfer might generate a fault response.
- The DP requests removal of power to a domain by deasserting **CxxxPWRUPREQ**.

The power controller deasserts **CxxxPWRUPACK** when it has accepted the request to power down the domain.

———— **Note** —————

The power controller deasserting **CxxxPWRUPACK**, does not indicate that the domain has been powered down, it only indicates that the power controller has recognized and accepted the request to remove power.

- **CxxxPWRUPACK** must default to the LOW state, and only go HIGH on receipt of a **CxxxPWRUPREQ** request.
- After detecting the deassertion of **CxxxPWRUPREQ**, the power controller must gracefully power down the domain, unless removal of power from the domain would affect system operation. For example, the power controller might maintain power to the domain if it has other requests to maintain power.
- After powerdown has been requested through the deassertion of **CxxxPWRUPREQ**, tools must wait until **CxxxPWRUPACK** is LOW before making a new request for powerup.

This requirement ensures that the power control handshaking mechanism is not violated.

Figure B2-1 shows the timing of the power control signals.

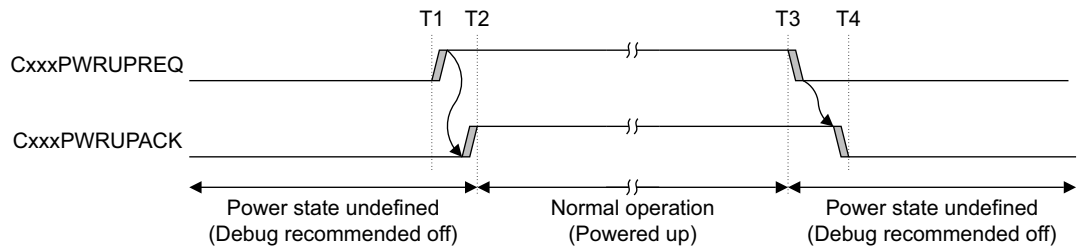

Figure B2-1 Powerup request and acknowledgment timing

———— **Note** ————

Arm strongly recommends that all AP transactions are initiated between T2 and T3 for **CDBGPWRUPREQ** and **CDBGPWRUPACK**, as shown in [Figure B2-1 on page B2-84](#).

B2.3.3 Emulation of powerdown

If a DP asserts **CxxxPRWUPREQ** for a domain, and the power controller receives a conflicting request for the domain from another source, it must emulate the powerdown request for the domain by completing the handshake process as expected, without actually removing power from the domain. This requirement enables debugging a system with power domains that power up and down dynamically.

The following requests cause a conflict when issued by another source after the DP has asserted **CxxxPRWUPREQ**:

- A powerdown request.
- A request to enter a low-power retention mode, with clocks disabled.

Emulation of powerdown is relevant to application debugging, when the application developer does not care whether the core domain actually powers up and down because this aspect is controlled at the OS level.

B2.3.4 Emulation of power control

If the system to which a DP is connected does not support the ADIv6 power control model, the required signals must be emulated or generated from other signals:

System power controllers that do not support the ADIv6 power control scheme

To ensure that the DP receives an immediate acknowledgment after initiating or removing a powerup request, connect **CxxxPRWUPACK** to **CxxxPRWUPREQ**, as shown in [Figure B2-2](#).

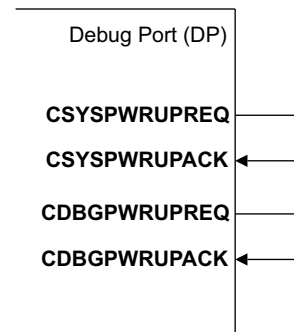

Figure B2-2 Emulation of powerup control

System power controllers that do not support separate power domains

If the debug power domain is part of the system power domain, **CSYSPWRUPREQ** and **CDBGPWRUPREQ** can independently request powerup. To correctly emulate power control:

- To ensure that the DP receives an immediate acknowledgment of after initiating or removing a system powerup request, connect **CSYSPWRUPACK** to **CSYSPWRUPREQ**.
- Generate appropriate **CxxxPRWUPACK** signals that ensure that the DP sees the correct response when it asserts **CxxxPRWUPREQ**.

The **CxxxPRWUPACK** signals must be emulated as described. Setting **CTRL/STAT.CSYSPWRUPREQ** to 0b1 and **CTRL/STAT.CDBGPWRUPREQ** to 0b0 in the **CTRL/STAT** register leads to UNPREDICTABLE system behavior.

The connections are shown in [Figure B2-3 on page B2-86](#).

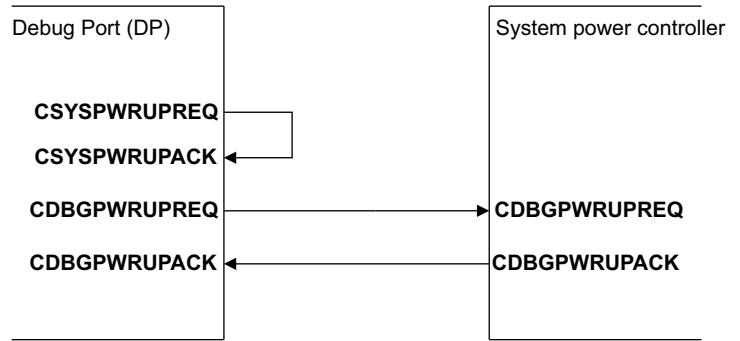

Figure B2-3 Signal generation for a single system and debug power domain

B2.4 Debug reset control behavior

The DP [CTRL/STAT](#) register provides two fields for reset control of the debug domain:

CDBGRSTREQ, bit[26] Debug reset request.

CDBGRSTACK, bit[27] Debug reset acknowledge.

The associated signals, **CDBGRSTREQ** and **CDBGRSTACK**, provide a connection to a system reset controller. The debug domain that is controlled by these signals covers some of the ADI, and the connection between the ADI and the debug components, for example the debug bus.

The DP registers are in the always-on power domain on the external interface side of the DP. Therefore, the registers can be driven at any time, to generate a reset request to the system reset controller.

Figure B2-4 shows the reset request and acknowledge timing.

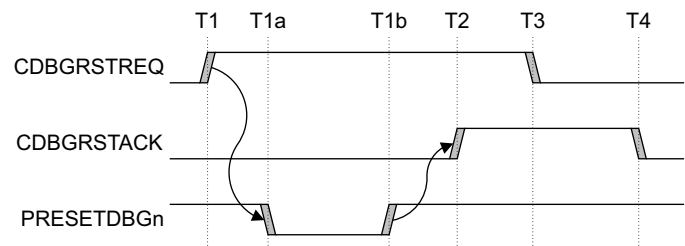

Figure B2-4 Reset request and acknowledge timing

———— **Note** ————

The use of AMBA APB signal names in the examples does not indicate a requirement that a debug bus must be implemented using an AMBA APB.

The steps in Figure B2-4 include:

- At T1, the debugger writes 0b1 to [CTRL/STAT.CDBGRSTREQ](#), which initiates the reset request. The debug domain is reset between T1a and T1b, and the reset is complete by T2. This operation resets the AP registers and other AP state.

———— **Note** ————

There is no reset of the DP registers and DP state. These registers are only reset by a powerup reset.

- At T2, the system reset controller acknowledges that the reset of the debug domain has completed. The **CDBGRSTACK** signal sets the [CTRL/STAT.CDBGRSTACK](#) bit to 0b1.
- At T3, the debugger checks the DP [CTRL/STAT](#) register and finds that the reset has completed. Therefore, it writes 0b0 to [CTRL/STAT.CDBGRSTREQ](#), which removes the reset request signal.
- At T4, the system reset controller recognizes that **CDBGRSTREQ** is no longer asserted, and deasserts **CDBGRSTACK**.

———— **Caution** ————

If **CDBGRSTREQ** is removed before the reset controller asserts **CDBGRSTACK**, the behavior is UNPREDICTABLE.

The AP debug components are also reset on powerup of the debug power domain.

A debug reset request has no effect on devices that are powered down when the request is issued.

B2.4.1 Emulation of debug reset request

If the debug reset control is not supported then:

- It is IMPLEMENTATION DEFINED whether CTRL/STAT.CDBGRESTREQ is read/write or RAZ/WI.
- CTRL/STAT.CDBGRESTACK is RAZ.

———— **Note** —————

Arm recommends tying CDBGRESTACK LOW so that the debugger can use a timeout mechanism to detect whether debug reset is implemented.

B2.4.2 Limitations of CDBGRESTREQ and CDBGRESTACK

Debug reset control behavior on page B2-87 shows how these bits can drive the debug reset signal, PRESETDBGn. In an actual system, there might be other reset signals that are associated with other debug buses. For example, in an Arm CoreSight system, ATRESETn resets all registers in the AMBA Trace Bus domain.

———— **Note** —————

It is IMPLEMENTATION DEFINED which components are reset by CDBGRESTREQ. *Figure B2-4 on page B2-87* is an example only. Not only components that use PRESETDBGn are reset.

Because debug logic might be accessible by the system, an implementation might have corner cases if CDBGRESTREQ is set at the same time as the system is using the debug logic. For example, the reset might occur during a transaction, causing a system or software malfunction.

It is IMPLEMENTATION DEFINED whether CDBGRESTREQ can be used when debug power is off.

A system might include IMPLEMENTATION DEFINED conditions which prevent a debug reset from occurring, for example when certain levels of debug are not permitted.

When a debug reset is prevented from occurring, CDBGRESTREQ is ignored and CDBGRESTACK is held LOW.

———— **Caution** —————

System-level use of debug components must be handled with caution. Arm recommends that such system-level usage is not combined with a reset system that permits those debug components to be reset without the knowledge of the system. Arm recommends that debuggers do not use debug reset requests unless necessary.

B2.5 System reset control behavior

The DP does not provide control bits for requesting a system reset. However, it is common for the physical interface to the debugger to include a system reset pin, **nSRST**. This section describes the recommended behavior of the system when a system reset is requested on the **nSRST** pin.

nSRST is an active-LOW pin that can be asserted and deasserted at any point in time, regardless of the current state of the target system, to return the target system to a known state for booting and for starting a debug session.

While **nSRST** is asserted:

- The target system must be held in the known state.
- The debugger must be able to access the debug domain of the target system.

B2.5.1 Limitations of system reset control

The debugger must ensure that the DP is not accessing the system when asserting **nSRST**. When **nSRST** is asserted, the debugger can access the debug domain.

The effect of **nSRST** on the debug domain is IMPLEMENTATION DEFINED.

For example, to safely return the target system to a known state, the debug domain might also require to be reset. When **nSRST** is asserted, the entire system must be reset, including the debug domain. However, the debug domain must be released from reset to allow the debugger access. Only the non-debug domain is held in reset while **nSRST** is asserted.

Arm recommends that debuggers set `CTRL/STAT.CDBGPWRUPREQ` to `0b0` while **nSRST** is initially asserted.

Figure B2-5 shows a system reset timing example.

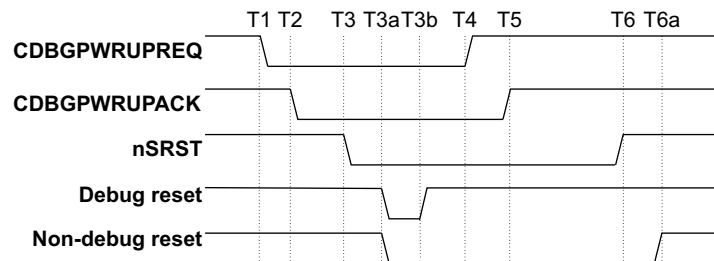

Figure B2-5 Example system reset timing

The steps in Figure B2-5 include:

1. At T1, the debugger writes `0b1` to `CTRL/STAT.CDBGPWRUPREQ`.
2. At T2, the system power controller acknowledges the request and `CTRL/STAT.CDBGPWRUPACK` is set to `0b0`.
3. At T3, the debugger asserts **nSRST**. The debug domain and non-debug domain are reset at time T3a. The debug domain reset is complete by time T3b.
4. At T4, the debugger writes `0b1` to `CTRL/STAT.CDBGPWRUPREQ`. This might occur before or after the debug reset is complete.
5. At T5, the system power controller acknowledges this request and signals the debug domain reset is complete by setting `CTRL/STAT.CDBGPWRUPACK` to `0b1`. The debugger can now program the debug domain.
6. At T6, the debugger releases **nSRST**. The non-debug domain reset completes at time T6a.

Chapter B3

The JTAG Debug Port

This chapter describes the implementation of the JTAG Debug Port (JTAG-DP), and in particular, the Debug Test Access Port (DBGTAP), the Debug Test Access Port State Machine (DBGTAPSM), and scan chains.

It is only relevant to ADI implementations that use a JTAG Debug Port. In this case, the JTAG-DP provides the external connection to the ADI, and all interface accesses are made using the scan chains, which are driven by the DBGTAPSM.

This chapter contains the following sections:

- [The scan chain interface on page B3-93.](#)
- [IR scan chain and IR instructions on page B3-96.](#)
- [DR scan chain and DR instructions on page B3-99.](#)

B3.1 About the JTAG-DP

The JTAG-DP is based on the *IEEE 1149.1 Standard for Test Access Port* and Boundary Scan Architecture, widely referred to as JTAG. To emphasize that the JTAG-DP is intended for accessing debug components, the naming convention that is used in this document differs from the IEEE 1149.1 naming convention by adding the prefix DBG, as shown in [Table B3-1](#).

Table B3-1 Comparison of IEEE 1149.1 and JTAG-DP naming

IEEE 1149.1 name	JTAG-DP name	JTAG-DP description
TAP	DBGTAP	Debug Test Access Port.
TAPSM	DBGTAPSM	Debug Test Access Port State Machine.

The signal naming conventions of IEEE 1149.1 are modified in a similar way, for example the IEEE 1149.1 **TDI** signal is named **DBGTDI** on a JTAG Debug Port. See [Physical connection to the JTAG-DP on page B3-93](#) for the complete list of the JTAG-DP signal names.

ADiv6 only permits DPs that implement DPv3 or later, and use JTAG DP Protocol version 1. JTAG DP Protocol version 1 introduces the following changes to earlier versions:

- [DPIDR](#) is valid for all DPv3 JTAG-DP implementations. [DLPIDR.PROTVSN](#) indicates the JTAG-DP protocol version. For details, see [DLPIDR, Data Link Protocol Identification Register on page B2-64](#).
- The response to DPACC and APACC accesses has changed to provide separate OK and FAULT responses. For details, see [OK or FAULT response to a DPACC or APACC access on page B3-103](#).
- The Overrun detection behavior is modified to align with the separated OK and FAULT responses. For details, see [Sticky overrun behavior on DPACC and APACC accesses on page B3-105](#).
- The JTAG-DP protocol version must be indicated by using a unique [IDCODE](#) value, to allow a debugger to determine the JTAG-DP protocol version. For details, see [IDCODE, the JTAG TAP ID register on page B3-110](#).

The JTAG DP Protocol that was used in ADI implementations of ADiv5 or earlier is referred to as JTAG DP Protocol version 0.

B3.2 The scan chain interface

When an ADI implementation has a JTAG-DP, the wire-level interface accesses the APACC scan chain to access debug resources in the system being debugged, or the DPACC scan chain to access information internal to the DP.

B3.2.1 DP elements

The DP requires the following elements to support JTAG scan chains:

- A DBGTAPSM.
- An *Instruction Register* (IR) that selects and controls the available scan chains.
- Various *Data Registers* (DRs) that hold the information that is exposed through the available scan chains and interface to:
 - The DP registers.
 - The debug registers in the device or debug component being accessed through the ADI.

Figure B3-1 shows how the scan chains provide access to the different levels of the ADI architecture. For more details, see Figure A1-3 on page A1-30.

Physical connection perspective

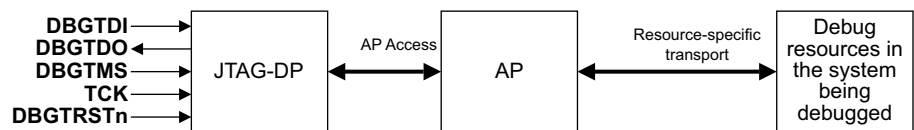

Scan chains perspective

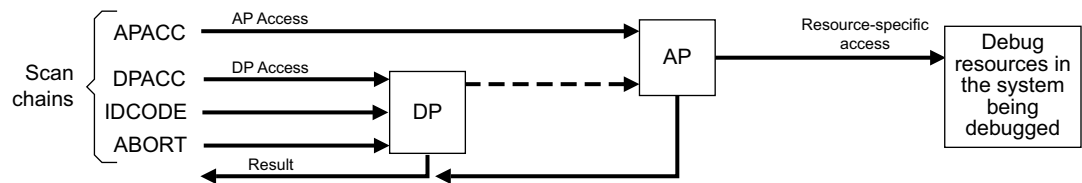

Figure B3-1 JTAG-DP scan chain access to the different levels of the ADI

B3.2.2 Physical connection to the JTAG-DP

The physical connection to the JTAG-DP closely follows the JTAG model. Table B3-2 lists the recommended signals for the JTAG-DP physical connection alongside their equivalent JTAG signal names.

Table B3-2 JTAG-DP signal connections

JTAG-DP signal name	JTAG equivalent signal name	Direction	Required?	Description
DBGTDI	TDI	Input	Yes	Debug Data In
DBGTDO	TDO	Output	Yes	Debug Data Out
TCK	TCK	Input	Yes	Debug Clock
DBGTMS	TMS	Input	Yes	Debug Mode Select
DBGTRSTn	TRST	Input	Optional	Debug TAP Reset

B3.2.3 The Debug TAP State Machine (DBGTAPSM)

The DBGTAPSM controls the operation of a JTAG-DP. In particular, it controls the scan chain interface that provides the external physical interface to the ADI through the JTAG-DP. It is based closely on the JTAG TAP State Machine. For more information, see *IEEE 1149.1-1990 IEEE Standard Test Access Port and Boundary Scan Architecture*.

Figure B3-2 shows the state diagram for the DBGTAPSM.

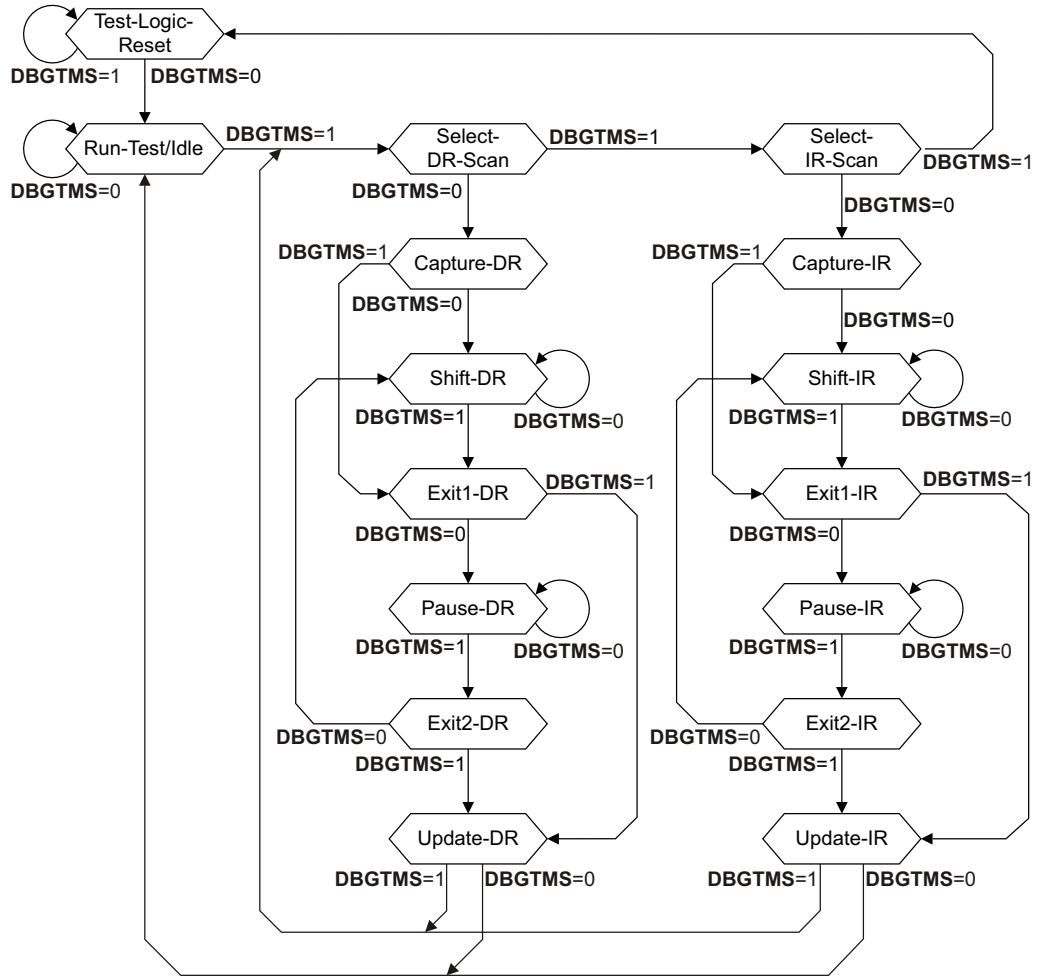

Based on IEEE Std 1149.1-1990. Copyright © 2006 IEEE. All rights reserved.
 Note that Arm signal names differ from those used in the IEEE diagram.

Figure B3-2 State diagram for the DBGTAPSM

The DBGTAPSM uses the following process:

- The **DBGTDI** signal input is the start of the scan chain and the **DBGTDO** signal output is the end of the scan chain.
- When the DBGTAPSM goes through the Capture-IR state:
 - When using a 4-bit IR, 0b0001 is transferred to the IR scan chain.
 - When using an 8-bit IR, 0b00000001 is transferred to the IR scan chain.
 - The IR scan chain is connected between **DBGTDI** and **DBGTDO**.

- While the DBGTAPSM is in the Shift-IR state, the IR scan chain advances one bit for each rising edge of **TCK**. On the first tick:
 - The LSB of the IR scan chain is output on **DBGTDO**.
 - Bit[1] of the IR scan chain is transferred to bit[0].
 - Bit[2] of the IR scan chain is transferred to bit[1].
 - Similarly, for every other bit n of the IR scan chain, bit[n] of the scan chain is transferred to bit[$n-1$].
 - The value on **DBGTDI** is transferred to the MSB of the IR scan chain.
- When the DBGTAPSM goes through the Update-IR state, the value that is scanned into the IR scan chain is transferred into the Instruction Register.
- The value that is held in the Instruction Register selects a Data Register, and an associated DR scan chain. When the DBGTAPSM goes through the Capture-DR state, the value of the selected DR is transferred to the selected DR scan chain, which is connected between **DBGTDI** and **DBGTDO**.
This data is then shifted while the DBGTAPSM is in the Shift-DR state, in the same manner as the IR shift in the Shift-IR state.
- When the DBGTAPSM goes through the Update-DR state, the value that is scanned into the DR scan chain is transferred into the selected Data Register.
- When the DBGTAPSM is in the Run-Test/Idle state, no special actions occur. Debuggers can use this state as a true resting state.

———— **Note** —————

This behavior is different from the behavior of previous versions of the ADI that were based on the IEEE JTAG standard. From ADIv5, there is no requirement for debuggers to gate **TCK** to obtain a true rest state.

To ensure that the transfer can be clocked through the JTAG-DP, after going through the Update-DR state the host must do one of the following:

- Start a new JTAG scan operation.
- Put the DBGTAPSM in to Run-Test/Idle, and remain in Run-Test/Idle until a new scan can be started.
- If the host is driving the JTAG clock, continue to clock the JTAG interface for at least eight cycles in Run-Test/Idle. After completing this sequence, the host can stop the clock.

The behavior of the IR and DR scan chains is described in more detail in [IR scan chain and IR instructions on page B3-96](#) and [DR scan chain and DR instructions on page B3-99](#).

The **DBGTRSTn** signal only resets the DBGTAP state machine and Instruction Register. **DBGTRSTn** asynchronously takes the DBGTAPSM to the Test-Logic-Reset state. As shown in [Figure B3-2 on page B3-94](#), the Test-Logic-Reset state can also be entered synchronously from any state by a sequence of five **TCK** cycles with **DBGTMS** HIGH. However, depending on the initial state of the DBGTAPSM, this transition might take the state machine through one of the Update states, with the resulting side effects.

The reset behavior of the registers is as follows:

- The DP registers are only reset on a powerup reset.
- The AP registers are reset on a powerup reset, and also by the Debug Reset Control described in [Debug reset control behavior on page B2-87](#).

B3.3 IR scan chain and IR instructions

This section describes the JTAG-DP IR, accessed through the IR scan chain.

B3.3.1 Required IR instructions

As described in *The Debug TAP State Machine (DBGTAPSM)* on page B3-94, the JTAG-DP transfers an instruction into the IR. This instruction determines the Data Register that the JTAG-DP Data Register maps onto, as described in *DR scan chain and DR instructions* on page B3-99.

The width of the IR is IMPLEMENTATION DEFINED, and can be 4 or 8 bits.

The standard IR instructions, which are required for all JTAG-DP implementations, are listed in Table B3-3, and recommended IMPLEMENTATION DEFINED extensions to this instruction set are described in *IMPLEMENTATION DEFINED extensions to the IR instruction set* on page B3-97.

Unused IR instruction values are reserved and select the **BYPASS** register.

Table B3-3 Standard IR instructions

4-bit IR instruction value	8-bit IR instruction value	Data register	DR scan length	Notes
0b0xxx	0b0xxxxxxx	-	-	<i>IMPLEMENTATION DEFINED extensions to the IR instruction set on page B3-97.</i>
-	0b10000000-0b11110111	-	-	Reserved.
0b1000	0b11111000	ABORT	35	-
0b1001	0b11111001	-	-	Reserved.
0b1010	0b11111010	DPACC	35	See <i>DPACC and APACC, JTAG-DP DP and AP Access registers</i> on page B3-102.
0b1011	0b11111011	APACC	35	
0b110x	0b1111110x	-	-	Reserved.
0b1110	0b11111110	IDCODE	32	-
0b1111	0b11111111	BYPASS	1	Required by JTAG specification.

B3.3.2 IMPLEMENTATION DEFINED extensions to the IR instruction set

The 4-bit IR instructions 0b0000 to 0b0111 and the 8-bit instructions 0b00000000 to 0b01111111 are reserved for IMPLEMENTATION DEFINED extensions to the ADI.

These instructions can be used for accessing a boundary scan register, for IEEE 1149.1 compliance, as shown in [Table B3-4](#). All these instructions select the boundary scan data register.

———— **Note** ————

This extension describes only boundary scan instructions that are described by IEEE 1149.1-2001. Later editions of IEEE 1149.1 define additional instructions.

Arm recommends that:

- Separate JTAG TAPs are used for boundary scan and debug.
- The instructions that are listed in [Table B3-4](#) are not implemented.

If the IR register is set to an IR instruction value that is not implemented, or reserved, then the [BYPASS](#) register is selected.

Table B3-4 Recommended IMPLEMENTATION DEFINED IR instructions for IEEE 1149.1-compliance

4-bit IR instruction value	8-bit IR instruction value	Instruction	Required by IEEE 1149.1?
0b0000	0b00000000	EXTEST	See note in main text.
0b0001	0b00000001	SAMPLE	Yes
0b0010	0b00000010	PRELOAD	Yes
0b0100	0b00000100	INTEST	No
0b0101	0b00000101	CLAMP	No
0b0110	0b00000110	HIGHZ	No

If a boundary scan implementation is required, it must implement the instructions that are required by IEEE 1149.1. The other IR instruction values that are listed in [Table B3-4](#) are reserved encodings that must be used if that function is implemented in the boundary scan. If implemented, these instructions must behave as required by the IEEE 1149.1 specification. If not implemented, they select the [BYPASS](#) register.

———— **Note** ————

The original revision of the IEEE 1149.1 specification, 1149.1-1990, requires that instruction {000. .0} is EXTEST. However, in more recent editions this requirement is removed and the IEEE 1149.1 specification recommends that instruction {000. .0} is reserved. See the IEEE specification for more details.

The IEEE 1149.1 specification also defines the [IDCODE](#) and [BYPASS](#) instructions, which are included in [Table B3-3 on page B3-96](#).

B3.3.3 IR, JTAG-DP Instruction Register

The [IR](#) characters are:

Purpose

Holds the current JTAG-DP Controller instruction.

Configurations

[IR](#) is mandatory in the IEEE 1149.1 standard.

Attributes

IMPLEMENTATION DEFINED, a 4-bit or 8-bit register.

Operation

The operation of the IR register is shown in the following figure:

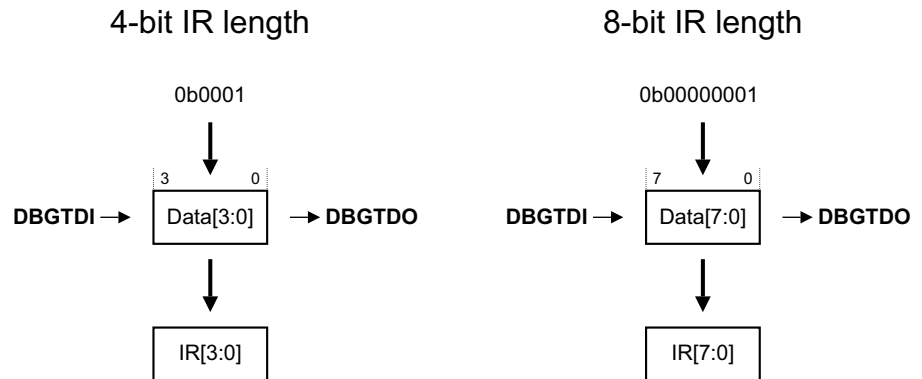

When in Shift-IR state, the shift section of the IR is selected as the serial path between **DBGTDI** and **DBGTDO**. At the Capture-IR state, the binary value 0b0001 for 4-bit instructions, or 0b00000001 for 8-bit instructions, is loaded into this shift section. This value is shifted out, least significant bit first, during Shift-IR, while a new instruction is shifted in, least significant bit first:

- At the Update-IR state, the value in the shift section is loaded into the IR and becomes the current instruction.
- In the Test-Logic-Reset state, **IDCODE** becomes the current instruction.

B3.4 DR scan chain and DR instructions

The DR scan chain is associated with the DR registers:

- The [BYPASS](#) and [IDCODE](#) registers, as defined by the IEEE 1149.1 standard.
- The DPACC and APACC Access registers, [xPACC](#).
- An [ABORT](#) register, to abort a transaction.

This section describes each of these registers.

The instruction in the [IR](#) register determines which of these scan chains is connected to the [DBGTDI](#) and [DBGTDO](#) signals, see [IR scan chain and IR instructions](#) on page B3-96.

B3.4.1 ABORT, JTAG-DP Abort register

The **ABORT** characteristics are:

Purpose

Access the **ABORT** register in the DP, to force an AP abort.

This implementation is the JTAG-DP implementation of the **ABORT** register.

Attributes

A 35-bit register.

Operation

The operation of the **ABORT** register is shown in the following figure:

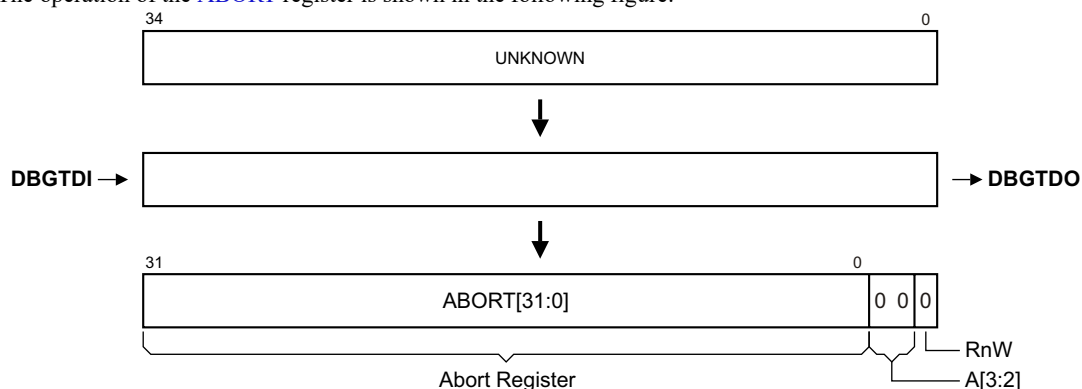

When the **ABORT** instruction is the current instruction in the IR, the serial path between **DBGTDI** and **DBGTDO** is connected to a 35-bit scan chain that accesses the **ABORT** register.

In DPv0, the effect of writing a value other than 0x00000001 to the **ABORT** register is UNPREDICTABLE. This means that, in DPv0, the debugger must scan the value 0x00000008 into this scan chain. For more information, see [ABORT, Abort register on page B2-53](#).

B3.4.2 BYPASS, JTAG-DP Bypass register

The **BYPASS** characteristics are:

Purpose

Bypasses the device, by providing a direct path between **DBGTDI** and **DBGTDO**.

Configurations

BYPASS is mandatory in the IEEE 1149.1 standard.

Attributes A 1-bit register.

Operation

The operation of the **BYPASS** register is shown in the following figure:

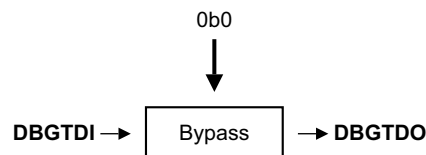

When the **BYPASS** instruction is the current instruction in the IR:

- In the Shift-DR state, data is transferred from **DBGTDI** to **DBGTDO** with a delay of one TCK cycle.

- In the Capture-DR state, a logic 0 is loaded into this register.
- In the Update-DR state, nothing happens. The shifted-in data is ignored.

B3.4.3 DPACC and APACC, JTAG-DP DP and AP Access registers

The DPACC and APACC scan chains have the same format.

Purpose

DPACC and APACC are used to read from and write to DP or AP registers.

The DPACC scan chain uses A[3:2], [SELECT.DPBANKSEL](#) and RnW to determine the address of the DP register to be accessed, as summarized in [Table B3-5](#). For detailed information about addressing JTAG-DP registers, see [DP architecture versions on page B2-50](#).

———— Note ————

The DP register [ABORT](#) is accessed through the ABORT instruction.

Table B3-5 JTAG-DP Register access summary.

Register	Access	Address (A ^a , SELECT.DPBANKSEL)			
		DPv0	DPv1	DPv2	DPv3
BASEPTR0	RO	-	-	-	0x0, 0x2
BASEPTR1	RO	-	-	-	0x0, 0x3
CTRL/STAT	RW	0x4, -	0x4, 0x0	0x4, 0x0	0x4, 0x0
DLCR	RW	-	0x4, 0x1	0x4, 0x1	0x4, 0x1
DLPIDR	RO	-	-	0x4, 0x3	0x4, 0x3
DPIDR	RO	-	0x0, x	0x0, x	0x0, 0x0
DPIDR1	RO	-	-	-	0x0, 0x1
EVENTSTAT	RO	-	-	0x4, 0x4	0x4, 0x4
RDBUFF	RO	0xC, -	0xC, x	0xC, x	0xC, x
SELECT	WO ^b	0x8, -	0x8, x	0x8, x	0x8, x
SELECT1	WO ^b	-	-	-	0x4, 0x5
TARGETID	RO	-	-	0x4, 0x2	0x4, 0x2

a. Bits [1:0] of the address are always 0b00.

b. RW for DPv0

- [MEM-AP programmers' model on page C2-198](#) for details of accessing MEM-AP registers.
- [JTAG-AP programmers' model on page C3-259](#) for details of accessing JTAG-AP registers.

Attributes

Two 35-bit registers.

Operation

The operation of the DPACC and APACC registers is shown in the following figure:

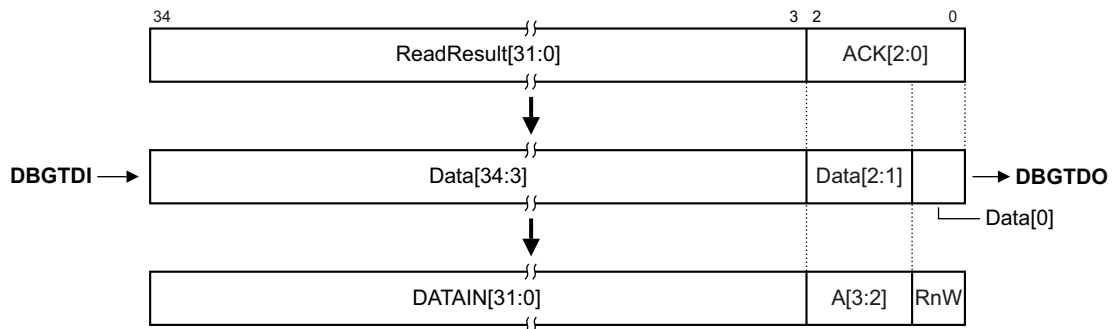

When the DPACC or APACC instruction is the current instruction in the IR, the shift section of the DP Access register or AP Access register is selected as the serial path between **DBGTDI** and **DBGTD0**:

- In the Capture-DR state, the result of the previous transaction, if any, is returned, together with a 3-bit ACK response. The ACK responses that are implemented for each JTAG DP Protocol version are summarized in [Table B3-6](#).

Table B3-6 DPACC and APACC ACK responses

JTAG DP Protocol Version	ACK[2:0] Encoding	Response	See:
0	0b001	WAIT	<i>WAIT response to a DPACC or APACC access on page B3-104</i>
0	0b010	OK/FAULT	<i>OK or FAULT response to a DPACC or APACC access</i>
1	0b001	WAIT	<i>WAIT response to a DPACC or APACC access on page B3-104</i>
1	0b010	FAULT	<i>OK or FAULT response to a DPACC or APACC access</i>
1	0b100	OK	<i>OK or FAULT response to a DPACC or APACC access</i>

All other ACK encodings are reserved.

This specification only describes responses that are defined for JTAG Protocol version 1. For details about JTAG DP Protocol version 0 implementations, see the ADIV5 edition of the architecture specification.

- In the Shift-DR state, this data is shifted out, least significant bit first. The first 3 bits of data that are shifted out are ACK[2:0].
As the returned data is shifted out to **DBGTD0**, new data is shifted in from **DBGTDI**, as described in *OK or FAULT response to a DPACC or APACC access*.
- Operation in the Update-DR depends on whether the ACK[2:0] response was OK/FAULT, OK, FAULT or WAIT, as described in:
 - *OK or FAULT response to a DPACC or APACC access.*
 - *WAIT response to a DPACC or APACC access on page B3-104.*

OK or FAULT response to a DPACC or APACC access

If the response indicated by ACK[2:0] is OK or FAULT, the previous transaction has completed. Additional information for FAULT responses can be obtained from the DP CTRL/STAT register.

Depending on the transaction type and the response code, ReadResult[31:0] must be handled as follows:

- If the previous instruction in the IR was not one of DPACC, APACC or BYPASS, the captured ReadResult[31:0] is UNKNOWN, and if Data[34:3] is shifted out it must be discarded.
- If the previous transaction was a read that was followed by an OK response, the captured ReadResult[31:0] is the requested register value. This result is shifted out as Data[34:3].
- If the previous transaction was a write, or a read that was followed by a FAULT response, the captured ReadResult[31:0] is UNKNOWN, and if Data[34:3] is shifted out it must be discarded.

An OK or FAULT response is followed by an Update-DR operation to fulfill the read or write request that is formed by the values that were shifted into the scan chain:

- **DBGTDI** and **DBGTDO** connect to the scan chain corresponding to the current IR instruction, and the specified address is used to select a register.
- For write requests, corresponding to RnW having a value of 0b0, the value in DATAIN[31:0] is written to the selected register.
- For read requests, corresponding to RnW having a value of 0b1, the value in DATAIN[31:0] is IGNORED. Another scan is required to obtain the read data.

Register accesses can be pipelined, because a single DPACC or APACC scan can return the result of the previous read operation at the same time as shifting in a request for another register access. At the end of a sequence of pipelined register reads, you can read the DP RDBUFF register to shift out the result of the final register read.

Reading the DP RDBUFF register has no effect on the operation of the DBGTAPSM. For details about returning the result from a previous DPACC or APACC scan, see section [Target response summary on page B3-105](#).

If the current IR instruction is APACC, an AP access is requested:

- If any sticky flag in the DP CTRL/STAT register is 1, the transaction is discarded. The next scan returns a FAULT response. For more information, see [Sticky flags and DP error responses on page B1-43](#).
- If pushed-compare or pushed-verify operations are enabled, the scanned-in value of RnW must be 0b0, otherwise behavior is UNPREDICTABLE. On Update-DR, a read request is issued, and the returned value is compared against DATAIN[31:0]. The CTRL/STAT.STICKYCMP flag is updated based on this comparison. For more information, see [Pushed-compare and pushed-verify operations on page B1-46](#).
Pushed operations are enabled using the CTRL/STAT.TRNMODE field.
- The AP access does not complete until the AP signals it as completed. For example, if a MEM-AP is accessed, the AP access might cause an access to a memory system connected to the MEM-AP. In this case, the AP access does not complete until the memory system signals to the MEM-AP that the memory access has completed.

WAIT response to a DPACC or APACC access

A WAIT response indicates that the previous transaction has not completed. Normally, after receiving a WAIT response the host retries the DPACC or APACC access.

————— Note —————

The previous transaction might be either a DP or an AP access. DP accesses are stalled, by returning WAIT, until any previous AP transaction has completed.

Normally, if software detects a WAIT response, it retries the same transfer, which enables the protocol to process data as quickly as possible. However, in case an abort mechanism is implemented, if the software has retried a transfer several times, and has waited long enough for a slow interconnect and memory system to respond, it might write to the **ABORT** register to cancel the operation. This action signals that the active AP must terminate the transfer that it is attempting, to permit access to other parts of the debug system. An AP might not be able to terminate a transfer on its SoC interface. However, on receiving an abort request, the AP must free its interface to the DP.

No request is generated at the Update-DR state, and the shifted-in data is discarded. The captured value of ReadResult[31:0] is UNKNOWN.

Sticky overrun behavior on DPACC and APACC accesses

The Sticky Overrun flag, CTRL/STAT.STICKYORUN is set to 0b1 if the response to any transaction is other than OK. If the Sticky Overrun flag is set:

- At the Capture-DR state, the response to a transaction is WAIT until the previous AP transaction has completed. As long as the previous transaction is not completed, subsequent scans also receive a WAIT response.
- Once the AP transaction has completed, the response is FAULT. Subsequent DPACC transactions respond with FAULT because the Sticky Overrun flag is set. Subsequent DPACC transactions, however, respond with OK, in particular to be able to access the CTRL/STAT register to confirm the Sticky Overrun flag status, and to clear the flag to 0b0 by writing 0b1 to CTRL/STAT.STICKYORUN, after gathering any required information about the overrun condition.

For more information, see [Sticky flags and DP error responses on page B1-43](#).

Minimum response times

As explained in [OK or FAULT response to a DPACC or APACC access on page B3-103](#), a DP or AP register access is initiated at the Update-DR state of one DPACC or APACC access, and the result of the access is returned at the Capture-DR state of the following DPACC or APACC access. If the requested register access has not completed, however, the second access generates a WAIT response.

The timing between the Update-DR state and the Capture-DR state is defined in terms of TCK cycles. Referring to [Figure B3-2 on page B3-94](#), there are two paths from the Update-DR state, where the register access is initiated, to the Capture-DR state, where the response is captured:

- A direct path through Select-DR-Scan.
- A path through Run-Test/Idle and Select-DR-Scan.

If the second path is followed, the state machine can spend a variable number of TCK cycles in the Run-Test/Idle state, which in turn varies the number of TCK cycles between the Update-DR and Capture-DR states.

A JTAG-DP implementation might impose an IMPLEMENTATION DEFINED lower limit on the number of TCK cycles between the Update-DR and Capture-DR states, and always generate an immediate WAIT response if Capture-DR is entered before this limit has expired. Although any debugger must be able to recover successfully from any WAIT response, Arm recommends that debuggers must be able to adapt to any IMPLEMENTATION DEFINED limit.

————— Note —————

Accessing AP registers or debug resources in connected device through an AP can be subjected to other variable response delays in the system. A debugger that can adapt to these delays and avoid wasting WAIT scans operates more efficiently and provides higher maximum data throughput.

Target response summary

As described in [OK or FAULT response to a DPACC or APACC access on page B3-103](#), a DP or AP register access is initiated at the Update-DR state of one DPACC or APACC access, and the result of the access is returned at the Capture-DR state of the following DPACC or APACC access. The target responses, at the Capture-DR state, for every possible DPACC and APACC access in the previous scan, are summarized in:

- [Table B3-7 on page B3-106](#), for cases where the previous scan was a DPACC access.
- [Table B3-8 on page B3-108](#), for cases where the previous scan was an APACC access.

Note

The target responses that are shown in [Table B3-7](#) are independent of the operation being performed in the current DPACC or APACC scan. In this table, Read result is the data that is shifted out as Data[34:3], and ACK is decoded from the data that is shifted out as Data[2:0].

Table B3-7 JTAG-DP target response summary, when previous scan^a was a DPACC access

Previous scan ^a , at Update-DR state		Current scan, at Capture-DR state			Response	
Access	A[3:2] ^b	DPBANKSEL	Sticky? ^c	APACC State ^d	ACK	Notes
X	0bXX	X	X	Busy	WAIT	If the Overrun Detect flag CTRL/STAT.ORUNDETECT is set to 0b1, this access-and-response sequence causes the Sticky Overrun flag CTRL/STAT.STICKYORUN to be set to 0b1. The value that is returned is UNKNOWN. See also CTRL/STAT, Control/Status register on page B2-57.
R	0b00	0x0	X	Not Busy	OK	Returns the value of DPIDR .
		0x1				Returns the value of DPIDR1 .
		0x2				Returns the value of BASEPTR0 on page B2-55.
		0x3				Returns the value of BASEPTR1 on page B2-55.
		Other				Returns RES0.
	0b01	0x0	Returns the value of CTRL/STAT .			
		0x1	Returns RES0.			
		0x2	Returns RES0.			
		0x3	Returns the value of DLPIDR .			
		0x4	Returns the value of EVENTSTAT .			
	Other	Returns RES0.				
	0b10	X	Returns RES0.			
	0b11	X	Returns RDBUFF value, always zero.			

Table B3-7 JTAG-DP target response summary, when previous scan^a was a DPACC access (continued)

Previous scan ^a , at Update-DR state			Current scan, at Capture-DR state		Response	
Access	A[3:2] ^b	DPBANKSEL	Sticky? ^c	APACC State ^d	ACK	Notes
W	0b00	X	X	Not Busy	OK	The result depends on the DP version: DPv2 Write is ignored, returns RES0. DPv0, DPv1 Behavior is UNPREDICTABLE.
	0b01	0x0				Value has been written to CTRL/STAT .
		0x5				Value has been written to SELECT1 on page B2-76 .
		Other				Write is ignored, returns RES0.
	0b10	X				Value has been written to SELECT on page B2-76 .
0b11	X				Writes to RDBUFF are ignored.	

- The previous scan is the most recent scan for which the ACK response at the Capture-DR state was OK or FAULT. Updates that are made following a WAIT response are discarded.
- A[3:2] in the DPACC access.
- The *Sticky?* column indicates whether any Sticky flag was set to 0b1 in the DP [CTRL/STAT](#) register.
- The state of the APACC transaction when the current scan reaches the Capture-DR state, or the response to the APACC at that time.

Table B3-8 JTAG-DP target response summary, when previous scan^a was an APACC access

Previous scan ^a , at Update-DR state		Current scan, at Capture-DR state		Response	
Access	A[3:2] ^b	Sticky? ^c	AP State ^d	ACK	Notes
X	X	X	Busy	WAIT	If the Overrun Detect flag <code>CTRL/STAT.ORUNDETECT</code> is <code>0b1</code> , this access and response sequence causes the Sticky Overrun flag <code>CTRL/STAT.STICKYORUN</code> to be set to <code>0b1</code> . See <i>CTRL/STAT, Control/Status register</i> on page B2-57.
R	X	No	Not busy	OK	If pushed-verify or pushed-compare is implemented and enabled, the behavior is UNPREDICTABLE and the value returned in the current scan is UNKNOWN. Otherwise, the return value is the APACC register that was addressed on the previous scan.
W	X	No	Not busy	OK	If pushed-verify or pushed-compare is implemented and enabled, the previous transaction performed the required pushed operation, that might have set the Sticky Compare flag <code>CTRL/STAT.STICKYCMP</code> to <code>0b1</code> . Otherwise, the data that is captured at the previous scan has been written to the APACC register requested. The value that is returned in the current scan is UNKNOWN.
X	X	Yes	Not busy	FAULT	If <code>CTRL/STAT.ERRMODE</code> is <code>0b1</code> , <code>CTRL/STAT.STICKYERR</code> is cleared to <code>0b0</code> at Update-DR of the current scan. If the current scan is a DPACC transaction, the transaction has been accepted. If the current scan is an APACC transaction, the transaction has been discarded. The value that is returned in the current scan is UNKNOWN.

- The previous scan is the most recent scan for which the ACK response at the Capture-DR state was OK or FAULT. Updates that are made following a WAIT response are discarded.
- A[3:2] in the APACC access.
- The *Sticky?* column indicates whether any Sticky flag was set to `0b1` in the DP `CTRL/STAT` register.
- The state of the APACC transaction when the current scan reaches the Capture-DR state.

If there has been no previous DPACC or APACC scan, or if the previous scan was an APACC transaction which was discarded due to a fault, the current scan behaves as follows, provided the APACC state is Not Busy:

- The value that is returned is UNKNOWN.
- If any Sticky flags are set to `0b1`, the ACK response is FAULT.
- If no Sticky flags are set to `0b1`, the ACK response is OK.

For a JTAG-DP, if the IR is changed to any instruction other than DPACC, APACC, or BYPASS, the DP behaves as if there has been no previous APACC or DPACC scan.

Host response summary

The ACK column, for the Current scan, at Capture-DR state section of [Table B3-7 on page B3-106](#) and [Table B3-8 on page B3-108](#), shows the responses that the host might receive after initiating a DPACC or APACC access. [Table B3-9](#) indicates the normal action of a host in response to each of these ACKs.

Table B3-9 Summary of JTAG-DP host responses

Access type	ACK from target	Suggested host action in response to ACK
Read	OK	Capture read data.
Write	OK	No action required.
Read or Write	WAIT	Repeat the same access until either an OK or FAULT ACK is received or the wait timeout is reached. If implemented, the host can activate the abort mechanism to enable access to the AP. For details, see ABORT, JTAG-DP Abort register .
Read or Write	invalid ACK	Assume that a target or line error has occurred and treat as a fatal error.
Read	FAULT	The read data that was returned is not valid: <ul style="list-style-type: none"> The read data should be discarded. The source of the FAULT response should be investigated and cleared. If necessary, the transaction should be repeated.
Write	FAULT	The write transaction has failed: <ul style="list-style-type: none"> The source of the FAULT response should be investigated and cleared. If necessary, the transaction should be repeated.

B3.4.4 IDCODE, the JTAG TAP ID register

The **IDCODE** characteristics are:

Purpose

JTAG-DP TAP identification. The **IDCODE** value enables a debugger to identify the Debug Port to which it is connected. JTAG-DP implementations have different **IDCODE** values, so that a debugger can distinguish between them.

When the IDCODE instruction is the current instruction in the IR, the shift section of the Device ID Code register is selected as the serial path between **DBGTDI** and **DBGTDO**:

- In the Capture-DR state, the 32-bit device ID code is loaded into this shift section.
- In the Shift-DR state, this data is shifted out, least significant bit first.
- Nothing happens at the Update-DR state. The shifted-in data is ignored.

Attributes

A 32-bit register.

Field Descriptions

The **IDCODE** bit assignments and operating mode are:

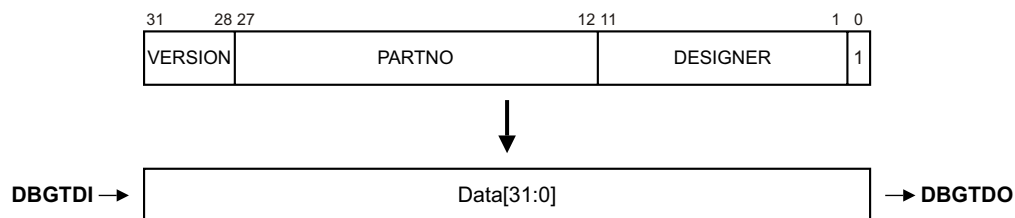

VERSION, bits[31:28]

Version code. The meaning of this field is IMPLEMENTATION DEFINED.

PARTNO, bits[27:12]

Part Number for the DP TAP. This value is provided by the designer of the Debug Port TAP and must not be changed.

DESIGNER, bits[11:1]

The Designer ID is an 11-bit JEDEC code that identifies the designer of the JTAG-DP TAP. It is formed from the JEDEC JEP106 continuation code and identity code as shown in [Table B3-10](#).

Table B3-10 JEDEC JEP106 manufacturer ID code, with Arm values

JEP106 field	Width (bits)	Bits in IDCODE	Arm registered value
Continuation code	4	Bits[11:8]	0b0100 (0x4)
Identity code	7	Bits[7:1]	0b0111011 (0x3B)

JEDEC codes are assigned by the JEDEC Solid State Technology Association, see *JEP106, Standard Manufacturer's Identification Code*.

Normally, this field identifies the designer of the ADIV6 implementation, rather than the system architect or the device manufacturer. If the DP is used for boundary scan, however, the field must conform to the JEDEC Manufacturer ID assigned to the manufacturer of the device.

The Arm default value for this field is 0x23B. Other designers must use their own JEDEC assigned code.

Bit[0]

RAO.

Chapter B4

The Serial Wire Debug Port

This chapter describes the implementation of the Serial Wire Debug Port (SW-DP), including the SWD interface. It is only relevant if the Arm Debug Interface implementation uses an SW-DP. In this case, the SW-DP provides the external connection to the debug interface, and all interface accesses are made using the SWD protocol summarized in this chapter.

———— **Note** —————

The Arm SWD interface is a synchronous serial interface. This specification does not describe the physical characteristics of the SWD interface, such as signal timings.

This chapter contains the following sections:

- [About the SWD protocol on page B4-114.](#)
- [SWD protocol operation on page B4-118.](#)
- [SWD interface on page B4-130.](#)

B4.1 About the SWD protocol

This section provides general information about the Arm SWD protocol. It contains the following sections:

- [Basic operation.](#)
- [SWD protocol versions.](#)
- [Line turnaround.](#)
- [Idle cycles.](#)
- [Bit order.](#)
- [Parity.](#)
- [Limitations of multi-drop.](#)

B4.1.1 Basic operation

The Arm SWD interface uses a single, bidirectional data connection and a separate clock to transfer data synchronously.

An operation on the wire consists of two or three phases:

Packet request

The external host debugger issues a request to the DP. The DP is the target of the request.

Acknowledge response

The target sends an acknowledge response to the host.

Data transfer phase

This phase is only present when either:

- A data read or data write request is followed by a valid (OK) acknowledge response.
- The [CTRL/STAT.ORUNDETECT](#) flag is 0b1.

The data transfer is one of:

- Target to host, following a read request (RDATA).
- Host to target, following a write request (WDATA).

If the [CTRL/STAT.ORUNDETECT](#) bit is 0b1, a data transfer phase is required on all responses, including WAIT and FAULT. For more information, see [Sticky overrun behavior on page B4-123](#).

When the SW-DP receives a packet request from the debug host, it must respond immediately by entering the acknowledge phase. There is a turnaround period between these phases, as they are in different directions. If a data phase is required, it follows immediately after the acknowledge phase.

For a write request, there is a turnaround period between the acknowledge phase and the WDATA data transfer phase. Following the WDATA data transfer phase the host continues to drive the wire. There is no additional turnaround period.

For a read request, there is no turnaround period between the acknowledge phase and the data transfer phase. There is a turnaround period following the RDATA data transfer phase, following which the host drives the wire.

To ensure that the transfer can be clocked through the SW-DP, after the data transfer phase the host must do one of the following:

- Immediately start a new SWD operation with the start bit of a new packet request.
- Continue to drive the SWD interface with idle cycles until the host starts a new SWD operation.
- If the host is driving the SWD clock, continue to clock the SWD interface with at least eight idle cycles. After completing this sequence, the host can stop the clock.

B4.1.2 SWD protocol versions

SWD protocol version 1 is a point-to-point architecture, supporting connection between a single host and a single device. It permits connection to multiple devices by providing extra connections from the host, which has several disadvantages:

- It complicates the physical connection standard, by having variants with different numbers of connections.
- It increases the number of pins that are required for the connector on the device PCB, which is unacceptable where size is a limiting factor.
- It increases the number of pins that are required on a package with multiple dies inside.
- It makes it difficult to integrate multiple platforms that are accessed by the SWD protocol into the same chip.

Techniques to solve this require connections that are shared between multiple Serial Wire devices. These connections are detrimental to the maximum speed of operation, but in many situations they provide an acceptable trade-off.

SWD protocol version 2 is a multi-drop architecture that:

- Enables a two-wire host connection to communicate simultaneously with multiple devices.
- Permits an effectively unlimited number of devices to be connected simultaneously, subject to electrical constraints.
- Is largely backwards-compatible, because provision for multi-drop support in a device does not break point-to-point compatibility with existing host equipment that does not support the multi-drop extensions. For more information, see [SWD protocol versions](#).
- Permits a device to power down completely, while the device is not selected.
- Prevents multiple devices from driving the wire simultaneously, and continues to support the wire being actively driven both HIGH and LOW, maintaining a high maximum clock speed.
- Permits multi-drop connections incorporating devices that do not implement the SWD protocol.

———— **Note** ————

SWD protocol version 2 requires the implementation of dormant state, which can limit its compatibility with SWD version 1:

- For an SWJ-DP implementation, JTAG is selected on a powerup reset. Selecting SWD bypasses the dormant state, and subsequent operation is compatible with SWD protocol version 1.
- For an SW-DP implementation of SWD protocol version 2, the dormant state is selected on a powerup reset, meaning the start-up state differs from a start-up with SWD protocol version 1. After SWD operation is selected, operation is compatible with SWD protocol version 1.

B4.1.3 Line turnaround

To prevent contention, a turnaround period is required when the device driving the wire changes. For the turnaround period, neither the host nor the target drives the wire, and the state of the wire is undefined. See also [Line pull-up on page B4-130](#).

———— **Note** ————

The line turnaround period can provide for pad delays when using a high sample clock frequency.

The length of the turnaround period is controlled by `DLCR.TURNROUND`. The default setting is a turnaround period of one clock cycle.

B4.1.4 Idle cycles

After completing a transaction, the host must either insert idle cycles or continue immediately with the start bit of a new transaction.

The host clocks the SWD interface with the line LOW to insert idle cycles.

B4.1.5 Bit order

All data values in SWD operations are transferred LSB first.

For example, the OK response of 0b001 appears on the wire as 1, followed by 0, followed by 0, as shown in [Figure B4-1 on page B4-119](#) and [Figure B4-2 on page B4-120](#).

B4.1.6 Parity

A simple parity check is applied to all packet request and data transfer phases. Even parity is used:

Packet requests

The parity check is made over the four bits APnDP, RnW and A[2:3]:

- If the number of bits with a value of 0b1 is odd, the parity bit is set to 0b1.
- If the number of bits with a value of 0b1 is even, the parity bit is set to 0b0.

Data transfers (WDATA and RDATA)

The parity check is made over the 32 data bits WDATA[0:31] or RDATA[0:31]:

- If the number of bits with a value of 0b1 is odd, the parity bit is set to 0b1.
- If the number of bits with a value of 0b1 is even, the parity bit is set to 0b0.

The packet request parity bit is shown in each of the diagrams in this section, from [Figure B4-1 on page B4-119](#) to [Figure B4-7 on page B4-124](#). It appears on the wire immediately after the A[2:3] bits. A parity error in the packet request is detected by the SW-DP, which responds with a protocol error. See [Protocol error response on page B4-122](#).

The WDATA parity bit is shown in [Figure B4-1 on page B4-119](#) and in [Figure B4-7 on page B4-124](#). It appears on the wire immediately after the WDATA[31] bit. A parity error in the WDATA data transfer phase is detected by the SW-DP and, other than writes to `TARGETSEL`, recorded in `CTRL/STAT.WDATAERR`. If overrun detection is enabled, it is IMPLEMENTATION DEFINED whether `CTRL/STAT.STICKYORUN` is set to 0b1. A parity error in a write to `TARGETSEL` deselects the target.

If a SWD write parity error occurs, the transaction is discarded and the register is not updated. This applies to both DP and AP writes.

The RDATA parity bit is shown in [Figure B4-2 on page B4-120](#). It appears on the wire immediately after the RDATA[31] bit. The debugger must check for parity errors in the RDATA data transfer phase and retry the read if necessary.

———— Note —————

The ACK[0:2] bits are never included in the parity calculation. Debuggers must remember this principle when parity checking the data from a read operation, when the debugger receives a continuous stream of 36 bits, as shown in [Figure B4-2 on page B4-120](#):

- Bit 35 is the parity bit.
- Bits 3-34 are RDATA[0:31].
- Bits 0-2 are ACK[0:2].

The parity check must be applied to bits 3-34 of this block of data, and the result must be compared with bit 35, the parity bit.

B4.1.7 Limitations of multi-drop

This section describes the configuration and auto-detection limitations of a multi-drop SWD system.

System configuration

Each device must be configured with a unique target ID, which includes a 4-bit instance ID, to differentiate between otherwise identical targets. The 4-bit ID places a limit of 16 such targets in any system. This limit means that identical devices must be configured before they are connected together to ensure that their instance IDs do not conflict.

Auto-detection of the target

It is not possible to interrogate a multi-drop SWD system that includes multiple devices to establish which devices are connected. For a target with multiple devices, because all devices are selected on coming out of a line reset, no communication with a device is possible without prior selection of that target using its target ID. Therefore, connection to a multi-drop SWD system that includes multiple devices requires that either:

- The host has prior knowledge of the devices in the system and is configured before target connection.
- The host attempts auto-detection by issuing a target select command for each of the devices it has been configured to support. While auto-detection is likely to involve many target select commands, it must be possible to iterate through all the supported devices in a reasonable time from the viewpoint of a user of the debug tools.

For this reason, debug tools cannot connect seamlessly to targets in a multi-drop SWD system that they have never seen before. If the debug tools can be provided with the target ID of such targets, however, the contents of the target can be auto-detected as normal.

To protect against multiple selected devices all driving the line simultaneously, the SWD protocol version 2 requires:

- For multi-drop SWJ-DP, the JTAG connection is selected out of powerup reset. JTAG does not drive the line. See [Chapter B5 The Serial Wire/JTAG Debug Port](#).
- For multi-drop SW-DP, the DP is in the dormant state out of powerup reset. See [Dormant operation on page B5-139](#).

B4.2 SWD protocol operation

This section gives an overview of the bidirectional operation of the protocol. It illustrates each of the possible sequences of operations on the SWD interface data connection.

———— Note —————

The diagrams in this section are included to show the operation of the SWD protocol. They are not timing diagrams for the protocol.

- [Successful write operation \(OK response\) on page B4-119.](#)
- [Successful read operation \(OK response\) on page B4-120.](#)
- [WAIT response to read or write operation request on page B4-121.](#)
- [FAULT response to read or write operation request on page B4-121.](#)
- [Protocol error response on page B4-122.](#)
- [Sticky overrun behavior on page B4-123.](#)
- [SW-DP write buffering on page B4-124.](#)

The illustrations of the different possible operations use the following terms:

Start	A single start bit, with value 0b1.
APnDP	A single bit, indicating whether the Debug Port or the Access Port Access register is to be accessed. This bit is 0b0 for a DPACC access, or 0b1 for an APACC access.
RnW	A single bit, indicating whether the access is a read or a write. This bit is 0b0 for a write access, or 0b1 for a read access.
A[2:3]	Two bits, giving the A[3:2] address field for the DP or AP register Address: <ul style="list-style-type: none">• For a DPACC access, the register being addressed depends on the A[3:2] value and, if A[3:2]≠0b01, the value that is held in SELECT.DPBANKSEL. For details, see DP architecture version 3 (DPv3) address map on page B2-51.• For an APACC access, the register being addressed depends on the A[3:2] value and the value that is held in SELECT.ADDR. For details about addressing, see:<ul style="list-style-type: none">— MEM-AP programmers' model on page C2-198 for accesses to a MEM-AP register— JTAG-AP programmers' model on page C3-259 for accesses to a JTAG-AP register.

———— Note —————

The A[3:2] value is transmitted Least Significant Bit (LSB) first on the wire, which is why it appears as A[2:3] on the diagrams.

Parity	A single parity bit for the preceding packet. See Parity on page B4-116.
Stop	A single stop bit. In the synchronous SWD protocol, this bit is always 0b0.
Park	A single bit. The host must drive the Park bit HIGH to park the line before tristating it for the turnaround period, to ensure that the line is read as HIGH by the target, which is required because the pull-up on the SWD interface is weak. The target reads this bit as 0b1.
Trn	Turnaround. See Line turnaround on page B4-115.

———— Note —————

All the examples that are given in this chapter show the default turnaround period of one cycle.

ACK[0:2]	A 3-bit target-to-host response.
-----------------	----------------------------------

———— Note —————

The ACK value is transmitted LSB-first on the wire, which is why it appears as ACK[0:2] on the diagrams.

Table B4-1 SWD ACK responses summary table

ACK[0:2] encoding	Response	See:
0b100	OK	<i>Successful write operation (OK response), Successful read operation (OK response) on page B4-120.</i>
0b010	WAIT	<i>WAIT response to read or write operation request on page B4-121.</i>
0b001	FAULT	<i>FAULT response to read or write operation request on page B4-121.</i>

WDATA[0:31]

32 bits of write data, from host to target.

Note

The WDATA value is transmitted LSB-first on the wire, which is why it appears as WDATA[0:31] on the diagrams.

RDATA[0:31]

32 bits of read data, from target to host.

Note

The RDATA value is transmitted LSB-first on the wire, which is why it appears as RDATA[0:31] on the diagrams.

B4.2.1 Successful write operation (OK response)

On receiving a write packet request, if the SW-DP is ready for the WDATA data transfer phase, and there is no error condition, it issues an OK response. This response is indicated by a response value of 0b001.

This response does not apply to writes to **TARGETSEL**. See *Connection and line reset sequence* on page B4-130.

Therefore, a successful write operation consists of three phases:

1. An 8-bit write packet request, from the host to the target.
2. A 3-bit OK acknowledge response, from the target to the host.
3. A 33-bit WDATA data transfer phase, from the host to the target.

By default, there are single-cycle turnaround periods between each of these phases. See *Line turnaround* on page B4-115 for more information.

A successful write operation is shown in **Figure B4-1**.

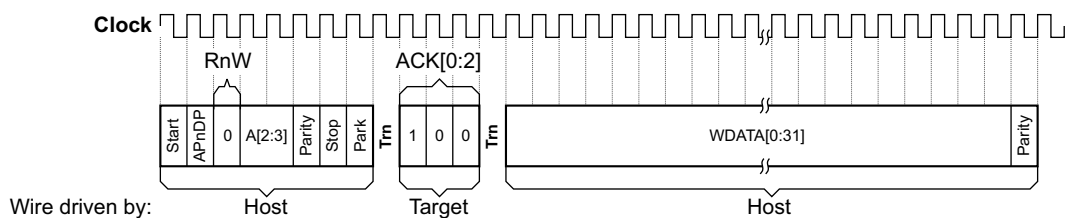

Figure B4-1 SWD successful write operation

The host must start transferring the write data immediately after receiving the OK acknowledge response from the target. This behavior is the same for writing to the DP or to an AP. The OK response that is shown in [Figure B4-1 on page B4-119](#) indicates that the DP is ready to accept the write data. The DP writes this data after the write phase has completed, and therefore the response to the DP write itself is given on the next operation. However, the SW-DP can buffer AP writes, as described in [SW-DP write buffering on page B4-124](#).

There is no turnaround phase after the data phase. The host is driving the line, and can start the next operation immediately.

B4.2.2 Successful read operation (OK response)

On receiving a read packet request, if the SW-DP is ready for the RDATA data transfer phase, and there is no error condition, it issues an OK response. This response is indicated by a response value of `0b001`.

Therefore, a successful read operation consists of three phases:

1. An 8-bit read packet request, from the host to the target.
2. A 3-bit OK acknowledge response, from the target to the host.
3. A 33-bit RDATA data transfer phase, where data is transferred from the target to the host.

By default, there are single-cycle turnaround periods between the first and second of these phases, and after the third phase. See [Line turnaround on page B4-115](#) for more information. However, there is no turnaround period between the second and third phases, because the line is driven by the target in both of these phases.

[Figure B4-2](#) shows a successful read operation.

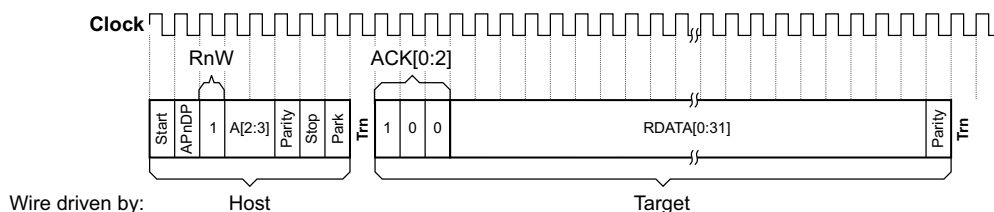

Figure B4-2 SWD successful read operation

If the host requested a read access to the DP, the SW-DP sends the read data immediately after the acknowledgment response.

Read accesses to the AP are posted, which means that the result of the access is returned on the next transfer. This result can be another AP register read, or a DP register read of `RDBUFF`.

To make a series of AP reads, a debugger only has to insert one read of the `RDBUFF` register:

- On the first AP read access, the read data that is returned is unknown. The debugger must discard this result.
- The next AP read access, if successful, returns the result of the previous AP read.
- This response can be repeated for any number of AP reads. Issuing the last AP read packet request returns the penultimate AP read result.
- The debugger can then read the DP `RDBUFF` register to obtain the last AP read result.

So that a debugger can recover from line errors, the next transaction after an AP register read can be any DP register read. If the next transaction is a DP register read other than a read of `RDBUFF` then a following AP register read or read of `RDBUFF` returns the result of the first AP register read.

If the next transaction following an AP register read is an AP register write or a DP register write, the result of the first AP register read is lost because any following AP register read or read of `RDBUFF` returns an UNKNOWN value.

B4.2.3 WAIT response to read or write operation request

If the SW-DP is not able to process the request from the debugger immediately, it must issue a WAIT response. A WAIT response to a read or write packet request consists of two phases:

1. An 8-bit read or write packet request, from the host to the target.
2. A 3-bit WAIT acknowledge response, from the target to the host.

By default, there are single-cycle turnaround periods between these two phases and after the second phase. See [Line turnaround on page B4-115](#) for more information.

A WAIT response to a read or write packet request is shown in [Figure B4-3](#).

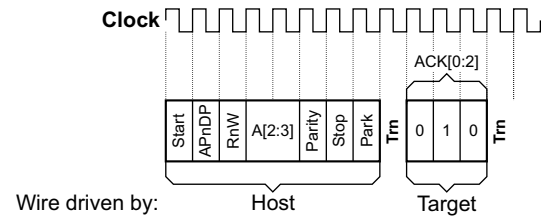

Figure B4-3 SWD WAIT response to a packet request

If overrun detection is enabled, `CTRL/STAT.STICKYORUN` is set to `0b1` and a data phase is required on a WAIT response. For more information, see [Sticky overrun behavior on page B4-123](#).

A WAIT response must not be issued in response to the following requests, which must always be processed immediately:

- Reads of the `DPIDR` register.
- Reads of the `CTRL/STAT` register.
- Writes to the `ABORT` register.

In response to any other request, if any of the following are true, the DP issues a WAIT response if it cannot process the request:

- A previous AP or DP access is outstanding.
- The new request is an AP read request and the result of the previous AP read is not yet available.

Normally, when a debugger receives a WAIT response it retries the same operation, to process data as quickly as possible. However, if several retries have been attempted, with a wait that is long enough for a slow interconnection and memory system to respond, the debugger might write to `ABORT.DAPABORT`, if appropriate. This value signals to the active AP that it must terminate the transfer that it is attempting. An AP implementation might be unable to terminate a transfer on its SoC interface, but on receiving an AP abort request the AP must free up the interface to the DP.

Writing to the `ABORT` register after receiving a WAIT response enables the debugger to access other parts of the debug system.

B4.2.4 FAULT response to read or write operation request

An SW-DP must not issue a FAULT response in response to:

- Reads of the `DPIDR` register, which is a read-only register.
- Reads of the `CTRL/STAT` register, which is a read/write register.
- Writes to the `ABORT` register, which is a write-only register.

For any other access, the SW-DP issues a FAULT response if any sticky flag is set to `0b1` in the `CTRL/STAT` register.

A FAULT response to a read or write packet request consists of two phases:

1. An 8-bit read or write packet request, from the host to the target.
2. A 3-bit FAULT acknowledge response, from the target to the host.

By default, there are single-cycle turnaround periods between these two phases, and after the second phase. See [Line turnaround on page B4-115](#) for more information.

A FAULT response to a read or write packet request is shown in [Figure B4-4](#).

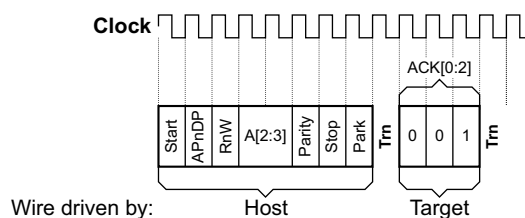

Figure B4-4 SWD FAULT response to a packet request

If overrun detection is enabled, `CTRL/STAT.STICKYORUN` is set to `0b1` and a data phase is required on a FAULT response. For more information, see [Sticky overrun behavior on page B4-123](#).

Use of the FAULT response enables the protocol to remain synchronized. A debugger might stream a block of data and then check the `CTRL/STAT` register at the end of the block.

In an SW-DP, the sticky error flags are cleared to `0b0` by writing bits in the `ABORT` register.

B4.2.5 Protocol error response

If any of the following occurs, a protocol error occurs:

- The Parity bit does not match the parity of the packet request.
 For more information about the parity checks in the SWD protocol, see [Parity on page B4-116](#).
- The Stop bit is not `0b0`.
- The Park bit is not `0b1`.
- `DLCR.TURNROUND` indicates an unsupported turnaround period.

———— **Note** —————

A mismatch between the Parity bit in the WDATA transfer phase and the parity of the data does not cause a protocol error response, because the SW-DP has already given its response to the header. For more information, see [Sticky flags and DP error responses on page B1-43](#).

Target response to protocol errors

On detecting a protocol error, the target enters the protocol error state.

If overrun detection is enabled, `CTRL/STAT.STICKYORUN` is set to `0b1` and the target must wait until the data phase of the transaction has completed before entering the protocol error state. Otherwise, it enters the protocol error state immediately.

When a protocol error is detected by the SW-DP, the SW-DP does not reply to the packet request and does not drive the line. This situation is illustrated in [Figure B4-5 on page B4-123](#).

———— **Note** —————

If SWD protocol version 2 is implemented, the SW-DP does also not reply to a `TARGETSEL` register write packet request.

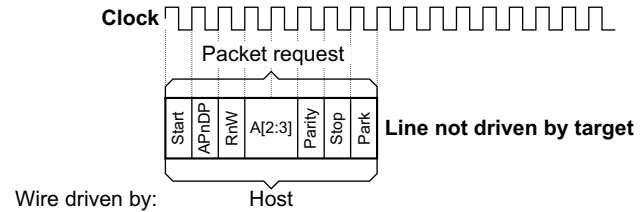

Figure B4-5 SWD protocol error after a packet request

In the protocol error state, the target behaves as follows:

- If the target detects a valid read of the DP [DPIDR](#) register, it is IMPLEMENTATION DEFINED whether the target leaves the protocol error state, and gives an OK response.
- If the target detects a valid packet header other than the read of the DP [DPIDR](#) register, or the target detects an IMPLEMENTATION DEFINED number of additional protocol errors, it enters the lockout state.
Arm recommends that the target enters the lockout state after one more protocol error is detected while in the protocol error state.

If the target cannot leave the protocol error state on a read of the [DPIDR](#) register, the protocol error and lockout states are equivalent.

The target must leave the protocol error state on a line reset.

The target only leaves the lockout state on a line reset.

If the SW-DP implements SWD protocol version 2, it must enter the lockout state after a single protocol error immediately after a line reset. However, if the first packet request detected by the target following line reset is valid it can then revert to entering the lockout state after an IMPLEMENTATION DEFINED number of protocol errors.

Host response to protocol errors

If the host does not receive an expected response from the target, it must not drive the line for at least the length of any potential data phase and then attempt a line reset. For more information, see [Connection and line reset sequence on page B4-130](#).

The host can attempt reads of the DP [DPIDR](#) register before attempting a line reset, as the target might respond and leave the protocol error state, but Arm does not recommend this solution.

If the transfer that resulted in the original protocol error response was a write, it can be assumed that no write occurred. If the original transfer was a read, it is possible that the read was issued to an AP. Although this scenario is unlikely, the possibility must be considered because reads are pipelined.

B4.2.6 Sticky overrun behavior

If an SW-DP receives a transaction request when the previous transaction has not completed, it returns a WAIT response. If overrun detection is enabled in the [CTRL/STAT](#) register, the [CTRL/STAT.STICKYORUN](#) flag is set to 0b1. Subsequent transactions generate FAULT responses, because a sticky flag is 0b1. If overrun detection is enabled, [CTRL/STAT.STICKYORUN](#) is also set if there is a FAULT response, protocol error, or line reset.

When overrun detection is enabled, WAIT and FAULT responses require a data phase:

- If the transaction is a read, the data in the data phase is UNKNOWN. The target does not drive the line, and the host must not check the parity bit.
- If the transaction is a write, the data phase is ignored.

[Figure B4-6 on page B4-124](#) shows the WAIT or FAULT response to a read operation when overrun detection is enabled.

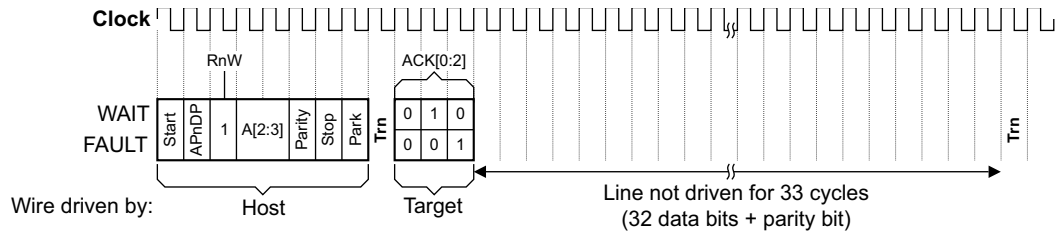

Figure B4-6 SW-DP WAIT or FAULT response to a read operation when overrun detection is enabled

Figure B4-7 shows the response to a write operation when overrun detection is enabled.

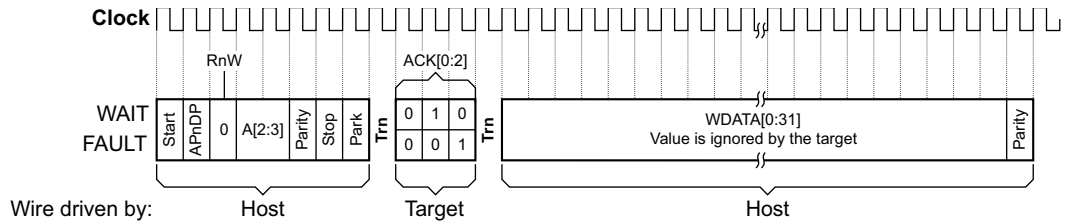

Figure B4-7 SW-DP WAIT or FAULT response to a write operation when overrun detection is enabled

B4.2.7 SW-DP write buffering

The SW-DP can implement a write buffer, enabling it to accept write operations even when other transactions are outstanding. If a DP implements a write buffer, it issues an OK response to a write request if it can accept the write into its write buffer. This response means that an OK response to a write request, other than a write to the **ABORT** register in the DP, indicates only that the write has been accepted by the DP. It does not indicate that all previous transactions have completed.

The maximum number of outstanding transactions, and the types of transactions that might be outstanding, when a write is accepted, are IMPLEMENTATION DEFINED. However, the DP must be implemented so that all accesses occur in order. For example, if a DP only buffers writes to AP registers and it has any buffered writes, it *must* stall on a DP register write access to ensure that the writes are performed in order.

If a write is accepted into the write buffer but later abandoned, the **CTRL/STAT.WDATAERR** flag is set to 0b1. A buffered write is abandoned if:

- A sticky flag is set to 0b1 by a previous transaction.
- A DP read of the **DPIDR**, **DPIDR1** or **CTRL/STAT** register is made. Because the DP must not stall reads of these registers, it must:
 - Perform the **DPIDR**, **DPIDR1** or **CTRL/STAT** register access immediately.
 - Discard any buffered writes, because otherwise they would be performed out-of-order.
 - Set the **WDATAERR** flag to 0b1.
- A DP write of the **ABORT** register is made. The DP must not stall an **ABORT** register access.

The flag being set means that if software makes a series of AP write transactions, it might not be possible to determine which transaction failed from examining the ACK responses, but it might be possible to use other inquiries to find which write failed. For example, if when using the *auto-address increment* (AddrInc) feature of a Memory Access Port, software can read the **TAR** to find the address of the last successful write transaction.

The write buffer must be emptied before the following operations can be performed:

- Any AP read operation.
- Any DP operation other than a read of the **DPIDR**, **DPIDR1**, or **CTRL/STAT** register, or a write of the **ABORT** register.

If the write buffer is not empty, attempting these operations causes a WAIT response from the DP.

———— **Note** ————

If pushed-verify or pushed-compare is enabled, AP write transactions are converted into AP reads. These transactions are then treated in the same way as other AP read operations. See [Pushed-compare and pushed-verify operations on page B1-46](#) for details of these operations.

If a DP read of the [DPIDR](#), [DPIDR1](#) or [CTRL/STAT](#) register, or a DP write to the [ABORT](#) register, is required immediately after a sequence of AP writes, the software must first perform an access that the DP is able to stall, to ensure that the write buffer is emptied before the DP register access is performed. If this access is not done, WDATAERR might be set to 0b1, causing the buffered writes to be lost.

———— **Note** ————

There is no requirement to insert an extra instruction to terminate the sequence of AP writes if the sequence of writes is followed by one of:

- An AP read operation.
- A write operation that can be stalled, such as a write to the [SELECT](#) register.

Often the requirement for an extra instruction can be avoided.

B4.2.8 Summary of target responses

The following subsections show the target SW-DP responses for different transaction requests:

- [Target SW-DP responses to DP transaction requests.](#)
- [Target SW-DP responses to AP transaction requests on page B4-127.](#)

Target SW-DP responses to DP transaction requests

For DP transaction requests, the register that is accessed is determined by:

- The value of A[3:2].
- When A[3:2] is 0b01, the value of [SELECT.DPBANKSEL](#).

The behavior of some read transaction requests depends on the register that is accessed, as [Table B4-2 on page B4-125](#) shows.

[Table B4-2 on page B4-125](#) shows the target SW-DP response to all possible debugger DP read operation requests.

[Table B4-3 on page B4-126](#) shows the target SW-DP response to all possible debugger DP write operation requests, assuming the WDATA parity check is good.

Table B4-2 Target response summary for DP read transaction requests

A[3:2]	SELECT. DPBANKSEL	Sticky flag value 0b1?	AP Ready?	SW-DP (target) response	
				ACK	Action
0b00	x	x ^a	x ^a	OK	Respond with register value.
0b01	0x0	x ^a	x ^a	OK	Respond with register value.
		No	Yes	OK	Respond with register value.
	No	No	WAIT	No data phase, unless overrun detection is enabled ^b .	
	Yes	x	FAULT	No data phase, unless overrun detection is enabled ^b .	

Table B4-2 Target response summary for DP read transaction requests (continued)

A[3:2]	SELECT. DPBANKSEL	Sticky flag value 0b1?	AP Ready?	SW-DP (target) response	
				ACK	Action
0b10	x	No	Yes	OK	Respond by resending the last read value that is sent to the host. This value is the result of one of: <ul style="list-style-type: none"> The most recent AP read The most recent DP RDBUFF read.
		No	No	WAIT	No data phase, unless overrun detection is enabled ^b .
		Yes	x	FAULT	No data phase, unless overrun detection is enabled ^b .
0b11	x	No	Yes	OK	Respond with the value from the previous AP read, and set CTRL/STAT.READOK bit to 0b1.
		No	No	WAIT	No data phase, unless overrun detection is enabled ^b . Set CTRL/STAT.READOK bit to 0b0.
		Yes	x	FAULT	No data phase, unless overrun detection is enabled ^b . Set CTRL/STAT.READOK bit to 0b0.

a. The SW-DP must always give an OK response to a read of the **DPIDR** or **CTRL/STAT** register.

b. See *Sticky overrun behavior* on page B4-123 for details about the data phase when overrun detection is enabled.

Table B4-3 Target response summary for DP write transaction requests

A[3:2]	Protocol version	Sticky flag value 0b1?	AP Ready?	SW-DP (target) response	
				ACK	Action
0b00	x	x	x	OK	Write WDATA value to ABORT register.
0b01 or 0b10	x	No	Yes ^a	OK	Write WDATA value to the selected DP register.
			No	WAIT	No data phase, unless overrun detection is enabled ^b .
			Yes	FAULT	No data phase, unless overrun detection is enabled ^b .

Table B4-3 Target response summary for DP write transaction requests (continued)

A[3:2]	Protocol version	Sticky flag value 0b1?	AP Ready?	SW-DP (target) response	
				ACK	Action
0b11	v1	No	Yes ^a	OK	Register is reserved, SBZ. Write is ignored.
			No	WAIT	No data phase, unless overrun detection is enabled ^b .
		Yes	x	FAULT	No data phase, unless overrun detection is enabled ^b .
	v2	x	x	None	Write WDATA to TARGETSEL register ^c .

- a. Writes might be accepted when other transactions are still outstanding. These writes might be abandoned later. See [SW-DP write buffering on page B4-124](#) for more information.
- b. See [Sticky overrun behavior on page B4-123](#) for details about the data phase when overrun detection is enabled.
- c. Target does not respond. See [Connection and line reset sequence on page B4-130](#).

Fault conditions that are not shown in these tables are described in [Fault conditions not included in the target response tables on page B4-128](#).

Target SW-DP responses to AP transaction requests

For AP transaction requests, the register that is accessed is determined by the value of A[3:2] combined with the values of [SELECT.ADDR](#). For more information, see [Using the AP to access debug resources on page A1-31](#).

[Table B4-4](#) summarizes the target SW-DP response to all possible debugger AP read operation requests.

[Table B4-5 on page B4-128](#) summarizes the target SW-DP response to all possible debugger AP write operation requests, assuming the WDATA parity check is good.

Table B4-4 Target response summary for AP read transaction requests

A[3:2]	Sticky flag value 0b1?	AP Ready?	SW-DP (target) response	
			ACK	Action
0bxx	No	Yes	OK	Normally ^a , return value from previous AP read ^b and set CTRL/STAT.READOK bit to 0b1. Initiate AP read of addressed register.
		No	WAIT	No data phase, unless overrun detection is enabled ^c . Set CTRL/STAT.READOK bit to 0b0.
	Yes	x	FAULT	No data phase, unless overrun detection is enabled ^c . Set CTRL/STAT.READOK bit to 0b0.

- a. If pushed-verify or pushed-compare is enabled, behavior is UNPREDICTABLE.
- b. On the first of a sequence of AP reads, the value that is returned in the data phase is UNKNOWN.
- c. See [Sticky overrun behavior on page B4-123](#) for details of data phase when overrun detection is enabled.

Table B4-5 Target response summary for AP write transaction requests

A[3:2]	Sticky flag value 0b1?	AP Ready?	SW-DP (target) response	
			ACK	Action
0bxx	No	Yes ^a	OK	Normally ^b , write WDATA value to the indicated AP register.
		No	WAIT	No data phase, unless overrun detection is enabled ^c .
	Yes	x	FAULT	No data phase, unless overrun detection is enabled ^c .

- Writes might be accepted when other transactions are still outstanding. These writes might be abandoned later. See [SW-DP write buffering on page B4-124](#) for more information.
- If pushed-verify or pushed-compare is enabled, the write is converted to a read of the addressed AP register, and the value that is returned by this read is compared with the supplied WDATA value, see [Pushed-compare and pushed-verify operations on page B1-46](#) for more information.
- See [Sticky overrun behavior on page B4-123](#) for details of data phase when overrun detection is enabled.

Fault conditions that are not shown in these tables are described in [Fault conditions not included in the target response tables](#).

Fault conditions not included in the target response tables

There are two fault conditions that are not included in possible operation requests listed in [Table B4-2 on page B4-125](#) to [Table B4-5](#):

Protocol error

If there is a protocol error, the target does not respond to the request at all, which means that when the host expects an ACK response, it finds that the line is not driven. See [Protocol error response on page B4-122](#).

WDATA fails parity check (write operations only)

The ACK response of the DP is sent before the parity check is performed, and is shown in [Table B4-3 on page B4-126](#). When the parity check is performed and fails, the CTRL/STAT.WDATAERR flag is set to 0b1.

B4.2.9 Summary of host responses

Every access by a debugger to an SW-DP starts with an operation request. [Summary of target responses on page B4-125](#) listed all possible requests from a debugger, and summarized how the SW-DP responds to each request.

Whenever a debugger issues an operation request to an SW-DP, it expects to receive a 3-bit acknowledgment, as listed in the ACK columns of [Table B4-2 on page B4-125](#) to [Table B4-5](#). [Table B4-6 on page B4-129](#) summarizes how the debugger must respond to this acknowledgment, for all possible cases.

———— Note —————

For SWD protocol version 2, this table does not apply to writes to TARGETSEL. See [Connection and line reset sequence on page B4-130](#).

Table B4-6 Summary of host (debugger) responses to the SW-DP acknowledge

Operation requested	ACK received	Host response	
		Data phase	Additional action
R	OK	Capture RDATA from target and check for valid parity ^a and protocol.	If a parity or protocol fault occurs and it is not possible to flag the data as invalid, the host may have to repeat original read request or use the RESEND register ^b .
	Invalid ACK	Back off because of possible data phase.	The host can check CTRL/STAT register to see if the response sent was OK.
W	OK	Send WDATA.	Validity of this transfer is confirmed on next access.
	Invalid ACK	Back off to ensure that target does not capture next header as WDATA.	Repeat the write access. A FAULT response is possible if the first response was sent as OK but not recognized as valid by the debugger. The subsequent write is not affected by the first, misread, response.
x	WAIT	No data phase, unless overrun detection is enabled ^c .	Normally, repeat the original operation request. See WAIT response to read or write operation request on page B4-121 for more information.
	FAULT	No data phase, unless overrun detection is enabled ^c .	Can send new headers, but only an access to DP register addresses <code>0b0X</code> gives a valid response.
	No ACK	Back off because of possible data phase.	Can attempt IDCODE register read. Otherwise reset connection and retrain. See Protocol error response on page B4-122 .

- a. See [Parity on page B4-116](#) for details of the parity checking.
- b. The host debugger might support corrupted reads, or it might have to retry the transfer.
- c. If overrun detection is enabled, a data phase is required. See [Sticky overrun behavior on page B4-123](#) for a description of the behavior on read and write operations.

B4.3 SWD interface

The SWD protocol uses a synchronous serial interface, which comprises a single bidirectional data signal, and a clock signal.

This section gives an overview of the physical SWD interface.

B4.3.1 Line interface

The SWD interface uses a single bidirectional data pin, **SWDIO**. The same signal is used for both host and target sourced signals.

The SWD interface is synchronous, and requires a clock pin, **SWCLK**.

When the target samples **SWDIO**, sampling is performed on the rising edge of **SWCLK**. When the target drives **SWDIO**, or stops driving it, signal changes are performed on the rising edge of **SWCLK**.

The clock can be sourced from the target and exported, or provided by the host. This clock is then used by the host as a reference for generation and sampling of data so that the target is not required to perform any over-sampling.

Both the target and host can drive the bus HIGH and LOW or tristate it. The ports must be able to tolerate short periods of contention that might occur because of a loss of synchronization.

The clock can be asynchronous to any system clock, including the debug logic clock. The SWD interface clock can be stopped when the debug port is idle, see [About the SWD protocol on page B4-114](#).

B4.3.2 Line pull-up

To make sure that the line is in a known state when neither host nor target is driving the line, a 100K Ω pull-up is required at the target. This pull-up can only be relied on to maintain the state of the wire. If the wire is driven LOW and released, the pull-up resistor eventually returns the line to the HIGH state, but this process takes many clock cycles.

The pull-up is intended to prevent false detection of signals when no host is connected, and must be of a suitably high value to reduce current consumption from the target when the host actively pulls down the line.

———— **Note** —————

A small current drains from the target whenever the line is driven LOW. If the interface is left connected for extended periods when the target has to use a low-power mode, the line must be held HIGH, or reset, by the host until the interface is activated.

B4.3.3 Connection and line reset sequence

A debugger must use a line reset sequence to ensure that hot-plugging the serial connection does not result in unintentional transfers. The line reset sequence ensures that the SW-DP is synchronized correctly to the header that signals a connection.

The SWD interface does not include a reset signal. A line reset is achieved by holding the data signal HIGH for at least 50 clock cycles, followed by at least two idle cycles. [Figure B4-8 on page B4-131](#) shows the interface timing for a line reset followed by a DP **DPIDR** register read.

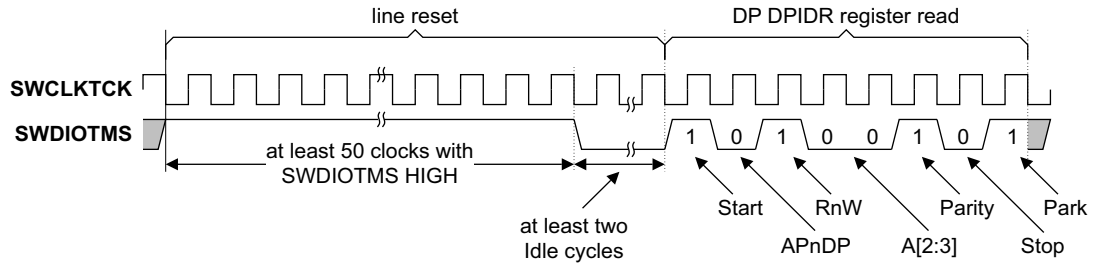

Figure B4-8 Line reset sequence followed by a DP DPIDR register read

A line reset is required when first connecting to the target. A line reset might be required following a protocol error. See [Protocol error response on page B4-122](#).

After a line reset:

- [DLCR](#) is reset.
- [SELECT.DPBANKSEL](#) must be reset to $0x0$.

Note

Other SW-DP registers are reset only by a powerup reset.

When waiting for a packet header, if the target detects a sequence of 50 clock cycles with the data signal held HIGH, followed by at least two idle cycles, it must enter the reset state. Whether a sequence of 50 clock cycles with the data signal held HIGH that is detected at any other time causes the interface to enter the reset state is IMPLEMENTATION DEFINED.

The only valid transactions in reset state are:

- A read of the [DPIDR](#) register. This transaction takes the connection out of reset state.
- One of the switching sequences defined by [Switching between SWD and JTAG on page B5-136](#), if implemented.
- A write to the [TARGETSEL](#) register, if SWD protocol version 2 is implemented. If this transaction selects the target, the interface remains in reset state.

Note

Only writes to [TARGETSEL](#) immediately after entry to the reset state can select or deselect the target. See [Target selection protocol, SWD protocol version 2](#).

Any of these sequences can be aborted by a second line reset. The behavior of the target is UNPREDICTABLE if any other transaction is made in reset state.

If the host does not see an expected response when reading the [DPIDR](#) register, it must retry the reset sequence, because the target might have been in a state where, for example, it treated the initial line reset as a data phase of a transaction and therefore did not detect it as a valid line reset. If so, the target detects the line reset as a protocol error and requires a second line reset to respond correctly.

If overrun detection is enabled, then the line reset sets [CTRL/STAT.STICKYORUN](#) to $0b1$.

B4.3.4 Target selection protocol, SWD protocol version 2

1. Perform a line reset. See [Figure B4-9 on page B4-132](#).
2. Write to DP register $0xC$, [TARGETSEL](#), where the data indicates the selected target. The target response must be ignored. See [Figure B4-9 on page B4-132](#).
3. Read from the DP register $0x0$, [DPIDR](#), to verify that the target has been successfully selected.

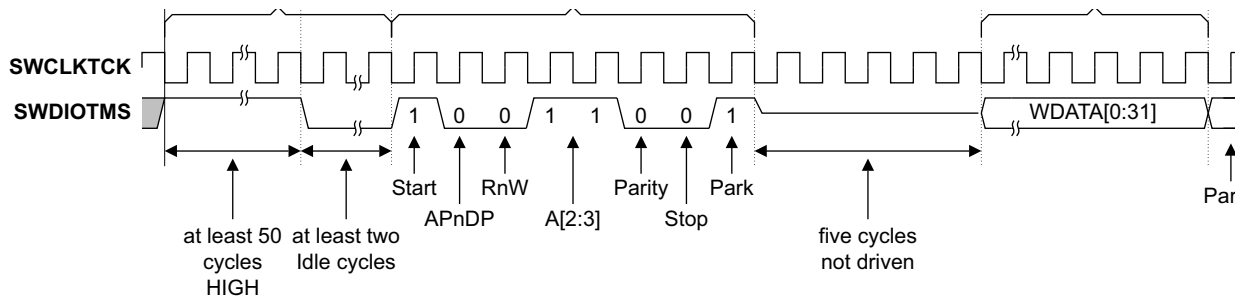

Figure B4-9 Line reset sequence followed by a DP TARGETSEL write

A write to the [TARGETSEL](#) register must always be followed by a read of the [DPIDR](#) register or a line reset. If the response to the [DPIDR](#) read is incorrect, or there is no response, the host must start the sequence again.

The target is selected on receiving a line reset sequence.

After receiving a line reset sequence, if the target receives a write request to [TARGETSEL](#) that does not select the same target, the target is deselected.

When deselected, the target ignores all accesses and must not drive the line. To select or deselect the target, a write to [TARGETSEL](#) must immediately follow a line reset sequence. Writes to [TARGETSEL](#) at any other time are UNPREDICTABLE.

If the target encounters a protocol error, it becomes deselected. Specifically, it does not respond to a read of the [DPIDR](#) register.

For more information, including the required behavior of the target during the response phase of the write to the [TARGETSEL](#) register, see [Sticky flags and DP error responses on page B1-43](#).

A parity error in the data phase of a write to the [TARGETSEL](#) register does not set the [CTRL/STAT.WDATAERR](#) bit to 0b1. A parity error in the data phase of a write to the [TARGETSEL](#) register is treated as a protocol error.

Accesses to the [TARGETSEL](#) register are not affected by the state of the [CTRL/STAT](#).{[WDATAERR](#), [STICKYERR](#), [STICKYCMP](#), [STICKYORUN](#)} bits.

Implementations of SWD protocol version 2 must also support dormant operation. See [Dormant operation on page B5-139](#).

Chapter B5

The Serial Wire/JTAG Debug Port

This chapter describes multiple protocol interoperability as implemented in the Serial Wire/JTAG Debug Port (SWJ-DP) CoreSight component. It contains the following sections:

- [About the SWJ-DP on page B5-134.](#)
- [Switching between SWD and JTAG on page B5-136.](#)
- [Dormant operation on page B5-139.](#)
- [Restrictions on switching between operating modes on page B5-146.](#)

B5.1 About the SWJ-DP

The SWJ-DP interface provides a mechanism to select between SWD and JTAG Data Link protocols. This enables the DP to provide JTAG and SWD connections while making efficient use of package pins through sharing, or overlaying, pins.

Implementing an SWJ-DP enables a SoC to connect to legacy JTAG equipment without the need to change the DP design. If an SWD tool is available, the JTAG interface is not needed, and only two pins are required, instead of the four or five used for JTAG. This frees up some pins for alternative use. See also [Limitations when reusing pins](#).

B5.1.1 SWJ-DP structure

The SWJ-DP comprises both an SW-DP and a JTAG-DP. It selects either the SW-DP or the JTAG-DP as the interface to the ADI, and switches between the SWD and JTAG Data Link protocols. Switching is achieved by routing the shared pins as shown in [Table B5-1](#).

Table B5-1 Routing of SWJ-DP pins

SWJ-DP pin	SW-DP pin	JTAG-DP pin
SWDIOTMS	SWDIO	TMS
SWDCLKTCK	CLK	TCK
TDO	-	TDO
TDI	-	TDI
TRSTn	-	TRSTn (optional)

The mechanism for switching between SWD and JTAG is described in [Switching from JTAG to SWD operation on page B5-137](#).

———— Note —————

While the DP is in SWD mode, the JTAG pins **TDI**, **TDO**, and **nTRST** are expected to be reused.

An SWJ-DP can be implemented in a package where the JTAG pins **TDI**, **TDO**, and **nTRST** are not connected because an SWJ-DP does not need these JTAG pins to switch the DP to SWD mode.

The following rules apply to SWJ-DP implementations:

- There is no requirement to implement separate SW-DP and JTAG-DP blocks within the SWJ-DP.
- The number, type and location of APs accessed by the SWJ-DP must not depend on whether the SW-DP or the JTAG-DP is selected, and each DP type must access the same debug resources. There is no requirement to implement these APs as shared APs.

For this reason, tools must not rely on the state of a DP or any AP it accesses to persist when the other DP is selected. After switching DPs, the debugger must re-initialize the DP, which includes setting the [CTRL/STAT](#).{CDBGPWUPREQ, CSYSPWUPREQ} bits correctly.
- The JTAG-DP and SW-DP programmers' models do not have to implement the same DP architecture version. See [Chapter B1 About the DP](#).
- If the JTAG protocol is never used, a pull-down on TDI at the target is required.

B5.1.2 Limitations when reusing pins

If the JTAG pins on the SWJ-DP interface are not used, they can be reused. There is, however, a trade-off between the number of pins that are used and compatibility with existing hardware and test equipment.

In the following situations the use of a JTAG debug interface must be maintained:

- The DP is included in an existing scan chain, which is often true for on-chip TAPs used for testing or other purposes.

- The device must be enabled to be cascaded with legacy devices which use JTAG for debug, although this requirement can also be supported using a JTAG-AP.
- There is a requirement to use existing debug hardware with the corresponding test TAPs, for example, in *Automatic Test Equipment* (ATE).

The following must be observed:

- When reusing pins, there must be no conflict with their use in JTAG operation.
- To support use of SWJ-DP in a scan chain with other JTAG devices, the default behavior after a DP reset must be to transition any reused pins from their alternative function to their JTAG function, if the direction of the alternative function is compatible with being driven by a JTAG debug device. The transition of the JTAG TAP to the Shift-DR or Shift-IR state can be used for this transition.
- The alternate function of reused pins cannot be used while the SoC is being used in JTAG operation.
- The switching scheme must enable a JTAG debugger to connect by sending a specific sequence, provided there is no conflict on the **TDI** and **TDO** pins.
- The connection sequence that is used for SWD must be safe when applied to the JTAG interface, even when hot-plugged, to enable the debugger to continually retry its access sequence.
- A sequence with **TMS HIGH** must ensure that all parts of the SWJ-DP are in a known reset state.
- The pattern that selects SWD must have no effect on JTAG devices.
- An SWJ-DP implementation must be compatible with a free-running **TCK**, or a gated clock, that is supplied by the external tools.

B5.2 Switching between SWD and JTAG

SWJ-DP enables either an SWD or JTAG protocol to be used on the debug port. This section describes in detail how the switching mechanism is implemented and how to switch between the two interfaces.

B5.2.1 The Switching Mechanism

The implementation uses a watcher circuit that detects a specific 16-bit select sequence on **SWDIOTMS**:

- A 16-bit sequence to switch from JTAG to SWD operation.
- A 16-bit sequence to switch from SWD to JTAG.

———— **Note** —————

Arm deprecates use of these sequences on devices where the dormant state of operation is implemented, and recommends using a transition through dormant state instead. For more information, see [Dormant operation on page B5-139](#).

SWJ-DP defaults to JTAG operation on powerup reset and therefore the JTAG protocol can be used from reset without sending a select sequence.

Switching from one protocol to the other can only occur when the selected interface is in its reset state. The JTAG TAP state machine must be in its *Test-Logic-Reset* (TLR) state and the SWD interface must be in line-reset. The powerup reset state for a JTAG TAP state machine is the Test-Logic-Reset state.

Having detected a switching sequence, SWJ-DP does not detect more sequences until after a reset condition. If JTAG is selected, the JTAG TAP state machine being in the TLR state is the reset condition. If SWD is selected, a line reset is the reset condition.

Figure B5-1 is a simplified state diagram that shows how SWJ-DP transitions between selected, detecting, and selection states.

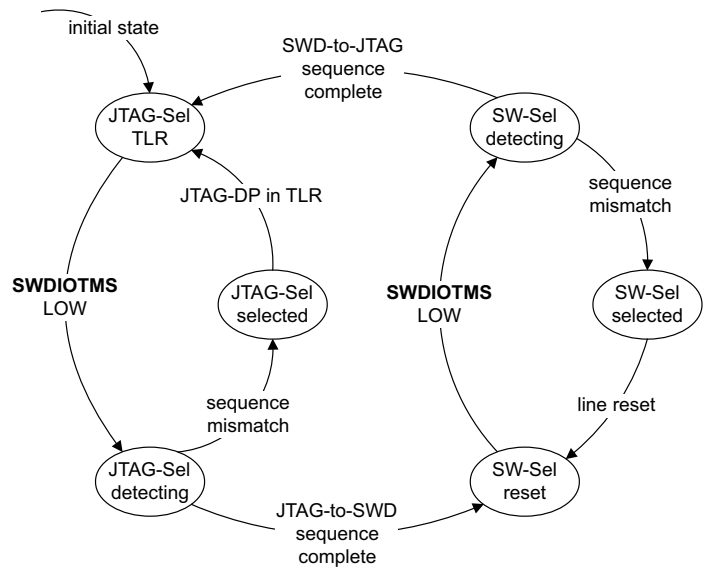

Figure B5-1 SWD and JTAG select state diagram

———— **Note** ————

In [Figure B5-1 on page B5-136](#):

- The JTAG-to-SWD sequence terminates in the SW-Sel reset state.
- The SWD-to-JTAG sequence terminates in the JTAG-Sel TLR state.

The recommended sequences end with a reset sequence for the selected state, to ensure that the target is in the relevant reset state.

The following applies to the preservation of the programmed state of a DP when switching from one protocol to another and back again:

- For ADIV5 or earlier, the programmed state of the original DP might be preserved.
- For ADIV6 or later, the state of the DP registers after a switch is UNKNOWN, and they must be programmed by the debugger before initiating any AP transactions. Programming the DP registers might include clearing any sticky errors.

B5.2.2 Switching from JTAG to SWD operation

To switch SWJ-DP from JTAG to SWD operation:

1. Send at least 50 **SWCLKTCK** cycles with **SWDIOTMS** HIGH. This sequence ensures that the current interface is in its reset state. The JTAG interface only detects the 16-bit JTAG-to-SWD sequence starting from the Test-Logic-Reset state.
2. Send the 16-bit JTAG-to-SWD select sequence on **SWDIOTMS**.
3. Send at least 50 **SWCLKTCK** cycles with **SWDIOTMS** HIGH. This sequence ensures that if SWJ-DP was already in SWD operation before sending the select sequence, the SWD interface enters line reset state.

The 16-bit JTAG-to-SWD select sequence is `0b0111 1001 1110 0111`, *most-significant-bit* (MSB) first. This sequence can be represented as one of the following:

- `0x79E7`, transmitted MSB first.
- `0xE79E`, transmitted *least-significant-bit* (LSB) first.

[Figure B5-2 on page B5-138](#) shows the interface timing.

[Figure B5-2 on page B5-138](#) shows the JTAG-to-SWD sequence begins immediately after the 50 cycles with **SWDIOTMS** HIGH. Unlike a normal line reset, the two cycles with **SWDIOTMS** low are not allowed.

This sequence has been chosen to ensure that the SWJ-DP switches to using SWD whether it was previously expecting JTAG or SWD. As long as the 50 cycles with **SWDIOTMS** HIGH sequence is sent first, the JTAG-to-SWD select sequence does not affect any of the following:

- SW-DP.
- The SWD and JTAG protocols that are used in the SWJ-DP.
- Any other TAP Controllers that might be connected to **SWDIOTMS**.

On selecting SWD operation, the SWD interface is in a reset state. See [Connection and line reset sequence on page B4-130](#).

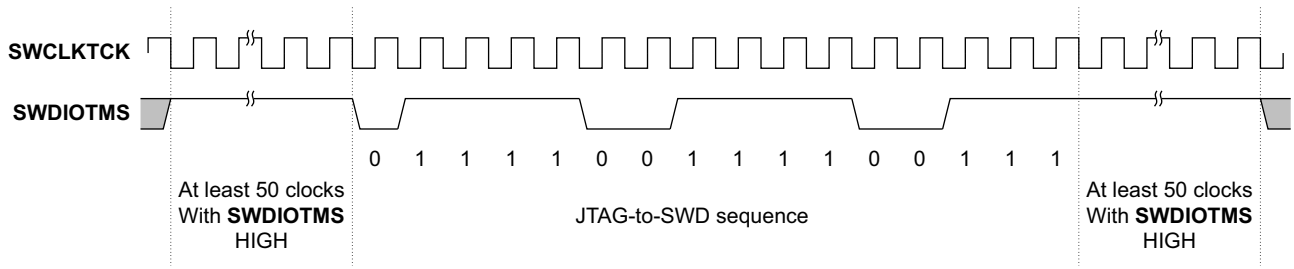

Figure B5-2 JTAG-to-SWD sequence timing

B5.2.3 Switching from SWD to JTAG operation

To switch SWJ-DP from SWD to JTAG operation:

1. Send at least 50 **SWCLKTCK** cycles with **SWDIOTMS** HIGH. This sequence ensures that the current interface is in its reset state. The SWD interface only detects the 16-bit SWD-to-JTAG sequence when it is in the reset state.
2. Send the 16-bit SWD-to-JTAG select sequence on **SWDIOTMS**.
3. Send at least five **SWCLKTCK** cycles with **SWDIOTMS** HIGH. This sequence ensures that if SWJ-DP was already in JTAG operation before sending the select sequence, the JTAG TAP enters the Test-Logic-Reset state.

The 16-bit SWD-to-JTAG select sequence is `0b0011 1100 1110 0111`, MSB first. This sequence can be represented as either of the following:

- `0x3CE7`, transmitted MSB first
- `0xE73C`, transmitted LSB first.

Figure B5-3 shows the SWD-to-JTAG sequence timing.

This sequence has been chosen to ensure that the SWJ-DP switches to using JTAG independent of whether it was previously expecting JTAG or SWD. If the **SWDIOTMS** HIGH sequence is sent first, the JTAG-to-SWD select sequence does not affect any of the following:

- SW-DP.
- The SWD and JTAG protocols that are used in the SWJ-DP.
- Any other TAP Controllers that might be connected to **SWDIOTMS**.

Figure B5-3 shows that the SWD-to-JTAG sequence begins immediately after the 50 cycles with **SWDIOTMS** HIGH. Unlike a normal line reset, the two cycles with **SWDIOTMS** LOW are not present.

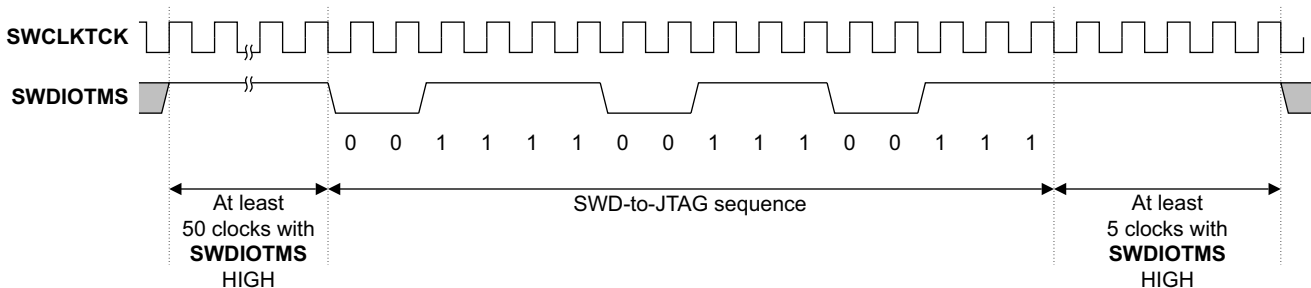

Figure B5-3 SWD-to-JTAG sequence timing

B5.3 Dormant operation

An alternative to the selection mechanism for switching between JTAG and SWD operation that is described in [Switching between SWD and JTAG on page B5-136](#) is the *dormant* state of operation.

To switch between JTAG and SWD operation, a debugger must first place the target into dormant state, and then transition to the required operating state.

Using dormant state allows the target to be placed into a quiescent mode, allowing devices to inter-operate with other devices implementing other protocols. Those other protocols must also implement a quiescent state, with a mechanism for entering and leaving that state that is compatible, but not necessarily compliant, with the SWJ-DP and SW-DP protocols.

Dormant operation is required by SWJ-DP and SW-DP implementations that implement SWD protocol version 2. SWD protocol version 2 is described in [Chapter B4 The Serial Wire Debug Port](#). Otherwise, support for dormant state is IMPLEMENTATION DEFINED. In the dormant state, the target must ignore any stimulus, with any timing, other than a defined Selection Alert sequence.

The Selection Alert sequence must be followed by a protocol-specific Activation code.

Selection of dormant state is possible when either JTAG or SWD operation is selected.

[Figure B5-4](#) extends the state diagram of [Figure B5-1 on page B5-136](#) to include selection of dormant state, for an SWJ-DP implementation.

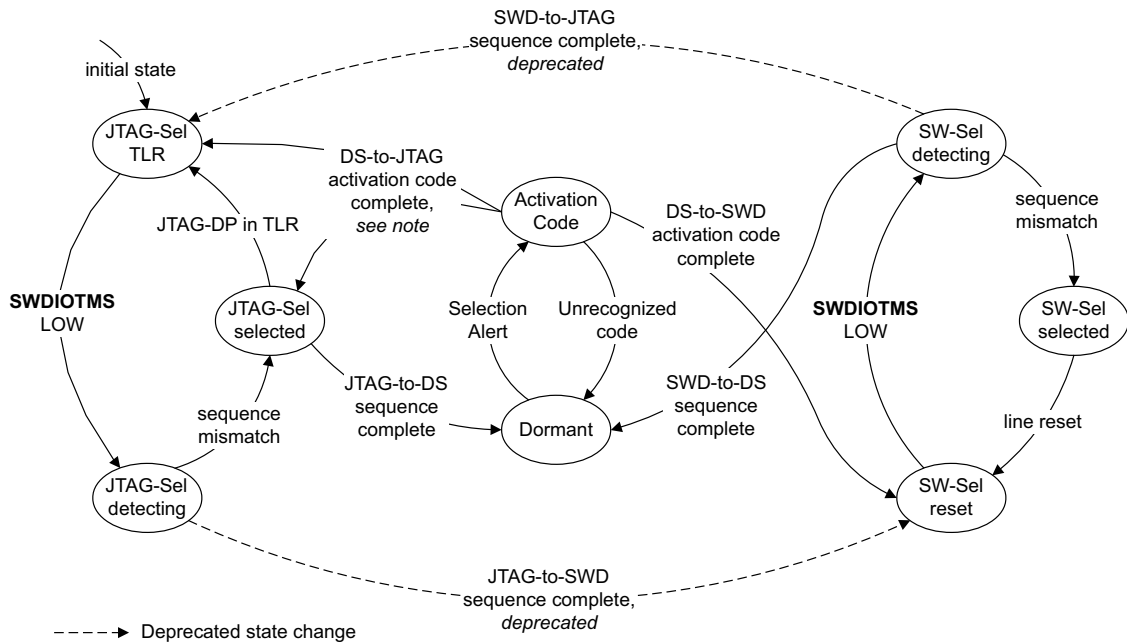

Figure B5-4 SWJ-DP selection of JTAG, SWD, and dormant states

Note

Following the DS-to-JTAG activation code, the JTAG TAP is in either the Test-Logic-Reset state or Run-Test/Idle state, and therefore this state machine is in either the JTAG-Sel TLR state or the JTAG-Sel selected state. Normally, the TAP state that the state machine returns to is the TAP state it left from. However, it is also possible to reset the JTAG TAP state machine when JTAG is not the selected protocol. To ensure that the TAP is in the Run-Test/Idle state, Arm recommends that the DS-to-JTAG sequence is followed by a single clock with **SWDIOTMS LOW**.

The DS-to-SWD sequence is shown terminating in the SW-Sel reset state. The recommended sequence ends with a line reset to ensure that the target is in the reset state.

B5.3.1 Using the dormant state outside of SWJ-DP

An SWD device that does not implement JTAG can nevertheless implement dormant state and inter-operate with SWJ-DP and other JTAG devices that also implement dormant state. In this case:

- The operating mode selection state machine is simplified.
- The initial state, entered on a powerup reset, is the dormant state.

Figure B5-5 shows the state diagram for an SW-DP that implements protocol version 2, meaning it supports dormant operation.

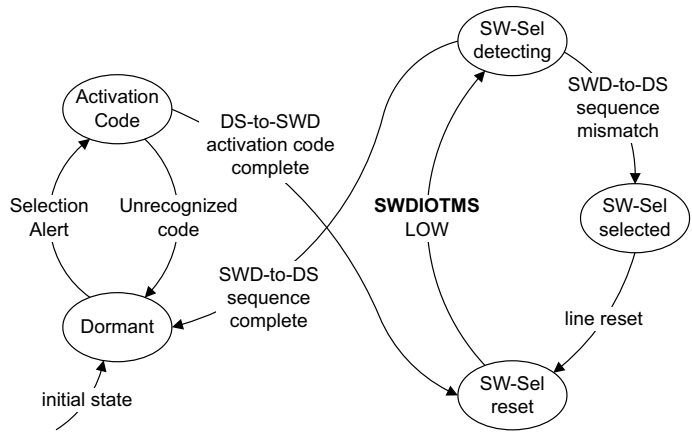

Figure B5-5 SW-DP selection of SWD, and dormant states

The dormant state enables multi-drop SWJ-DP, SW-DP, and JTAG TAPs to share a physical connection to a host, as shown in Figure B5-6. These different devices can be in different physical packages, or on different dies in a single package, or on a single die.

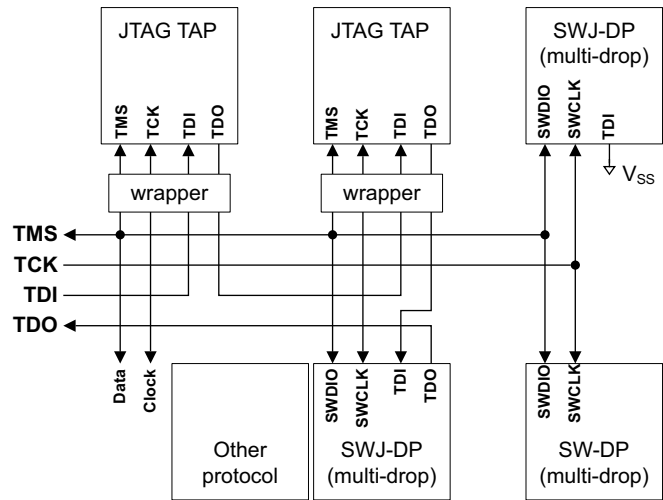

Figure B5-6 Multiple JTAG, SW, SWJ (multi-drop), and other protocol devices on shared connection

B5.3.2 Switching from JTAG to dormant state

To switch from JTAG to dormant state, a debugger must:

1. Send at least five **SWCLKTCK** cycles with **SWDIOTMS** HIGH. This sequence places the JTAG TAP state machine into the Test-Logic-Reset state, and selects the IDCODE instruction.
2. Send the recommended 31-bit JTAG-to-DS select sequence on **SWDIOTMS**.

The recommended 31-bit JTAG-to-DS select sequence is `0b010_1110_1110_1110_1110_0110`, MSB first. This sequence can be represented as either:

- `0x2EEEEEE6` transmitted MSB first, that is, starting from bit 30.
- `0x33BBBBBA` transmitted LSB first.

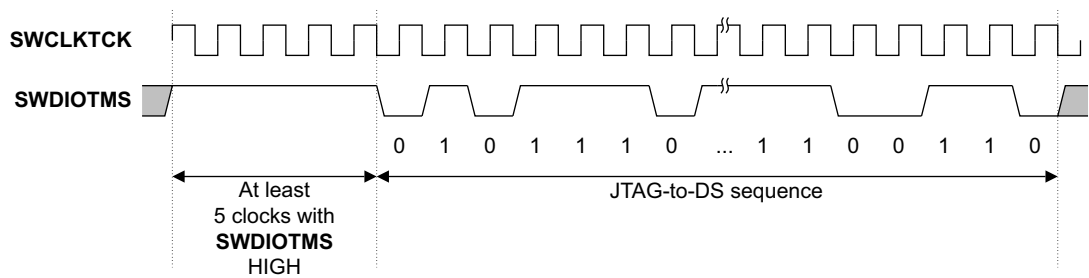

Figure B5-7 Recommended JTAG-to-DS sequence timing

Requirements for implementations

The JTAG-to-DS sequence is the shortest sequence that switches from JTAG-to-DS. For compatibility with other standards, all JTAG devices that implement dormant state must recognize other sequences as valid JTAG-to-DS select sequences.

The full sequence is defined around the concept of a *zero-bit-DR-scan* (ZBS or ZBS scan) which is in turn defined by transitions of the JTAG TAP state machine. A ZBS is defined as any JTAG TAP state machine sequence that starts at Capture-DR and ends in Update-DR without passing through Shift-DR.

Examples of a ZBS are:

- **Capture-DR → Exit1-DR → Update-DR**
- **Capture-DR → Exit1-DR → Pause-DR → ... → Pause-DR → Exit2-DR → Update-DR**

The sequence also uses the ZBS count, which is defined as follows:

- If the TAP state machine enters either the Select-IR-Scan or TLR state, the ZBS count is unlocked and reset to zero. This includes asynchronously entering TLR following assertion of **nTRST**. At reset, the ZBS count is unlocked and reset to zero.
- On entering Update-DR at the end of a ZBS scan, if the ZBS count is unlocked and less than seven, it is incremented by one.
- The counter does not increment past seven. On entering Update-DR at the end of a ZBS scan, if the ZBS count is unlocked and equal to seven, it is not incremented. The count does not wrap to zero.
- The ZBS count is locked if the TAP state machine enters the Shift-DR state and the ZBS count is not zero.

The JTAG-to-DS sequence is defined as any sequence of TAP state machine transitions that terminates in the Run-Test/Idle state with a locked ZBS count of six. On entering Run-Test/Idle, the target is placed into *Dormant State* (DS).

The behavior of the target on entering Run-Test/Idle with other locked ZBS counts is IMPLEMENTATION DEFINED.

Although the recommended JTAG-to-DS sequence starts by placing the JTAG TAP state machine in the Test-Logic-Reset state, this transition is not required for recognizing the JTAG-to-DS sequence. Tools must, however, ensure that the Instruction Register (IR) is loaded with either the BYPASS or IDCODE instruction before placing the target into the dormant state. If the IR is not loaded with either of these instructions when the target is put into dormant state, the behavior is unpredictable.

The pseudocode function `EnterDormantState` describes the function of the JTAG-to-DS sequence detector. It is notionally called on every TAP state machine transition. The function takes the state being entered as an argument, and returns a Boolean that indicates whether dormant state must be entered.

For details of the pseudocode language, see *Chapter J1, Armv8 Pseudocode* of the *Arm® Architecture Reference Manual, for A-profile architecture*.

```
enumeration TAPState {
    TestLogicReset, RunTestIdle,
    SelectDRScan, CaptureDR, ShiftDR, Exit1DR, PauseDR, Exit2DR, UpdateDR,
    SelectIRScan, CaptureIR, ShiftIR, Exit1IR, PauseIR, Exit2IR, UpdateIR};

boolean shiftDRflag = FALSE;
integer ZBScout = 0;
boolean ZBScoutLocked = FALSE;

// EnterDormantState()
// =====

boolean EnterDormantState(TAPState state)
    case state of
        when CaptureDR
            shiftDRflag = FALSE;
        when ShiftDR
            shiftDRflag = TRUE;

            if ZBScout != 0 then ZBScoutLocked = TRUE;
        when UpdateDR
            if !ZBScoutLocked && !shiftDRflag && ZBScout < 7 then
                ZBScout = ZBScout + 1;
        when SelectIRScan, TestLogicReset
            ZBScout = 0; ZBScoutLocked = FALSE;
        return state == RunTestIdle && ZBScoutLocked && ZBScout == 6;
```

————— **Note** —————

If the JTAG-to-DS sequence is terminated by entering the Test-Logic-Reset state, an SWJ-DP can immediately detect a JTAG-to-SWD sequence.

B5.3.3 Switching from SWD to dormant state

To switch from SWD to dormant state:

1. Send at least 50 **SWCLKTCK** cycles with **SWDIOTMS** HIGH. This sequence ensures that the SWD interface is in the reset state. The target only detects the SWD-to-DS sequence when it is in the reset state.
2. Send the 16-bit SWD-to-DS select sequence on **SWDIOTMS**.

The 16-bit SWD-to-DS select sequence is 0b0011_1101_1100_0111, MSB first. This sequence can be represented as either:

- 0x3DC7 transmitted MSB first.
- 0xE3BC transmitted LSB first.

[Figure B5-8 on page B5-143](#) shows that the SWD-to-DS sequence begins immediately after the 50 cycles with **SWDIOTMS** HIGH. Unlike a normal line reset, the two cycles with **SWDIOTMS** LOW are not present.

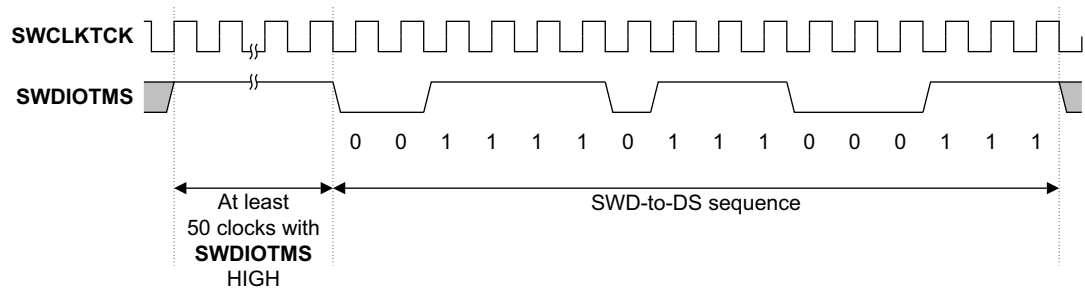

Figure B5-8 SWD-to-DS sequence timing

B5.3.4 Leaving dormant state

To ensure that the probability for any protocol being used to accidentally signal the DP to leave the dormant state is low, the sequence for leaving the dormant state is considerably longer than the sequence for entering it.

To signal the DP to leave the dormant state:

1. Send at least eight **SWCLKTCK** cycles with **SWDIOTMS** HIGH. This sequence ensures that the target is not in the middle of detecting a Selection Alert sequence. The target is permitted to detect the Selection Alert sequence even if this 8-cycle sequence is not present.
2. Send the 128-bit Selection Alert sequence on **SWDIOTMS**.
3. Send four **SWCLKTCK** cycles with **SWDIOTMS** LOW. The target must ignore the value on **SWDIOTMS** during these cycles.
4. Send the required activation code sequence on **SWDIOTMS**.
5. Send a sequence to place the target into a known state
 - If selecting JTAG, the target is in either the Run/Test Idle or TLR states, see the *Note* that follows [Figure B5-4 on page B5-139](#) for more information. Arm recommends that the debugger sends one **SWCLKTCK** cycle with **SWDIOTMS** LOW, to ensure that the TAP state machine is in the Run-Test/Idle state. Alternatively, send at least five **SWCLKTCK** cycles with **SWDIOTMS** HIGH to ensure that the TAP state machine is in the Test-Logic/Reset state.
 - If selecting SWD, the target is in the protocol error state. The debugger must send at least 50 **SWCLKTCK** cycles with **SWDIOTMS** HIGH. This sequence ensures that the SWD interface is in the line reset state.

———— **Note** ————

The Activation code selects a protocol, not a target. In a multidrop SWD system with multiple SW-DPs, a target must then be selected. For more information, see [Target selection protocol, SWD protocol version 2 on page B4-131](#).

The Selection Alert sequence, in binary, is

```
0100_1001_1100_1111_1001_0000_0100_0110_1010_1001_1011_0100_1010_0001_0110_0001_
1001_0111_1111_0101_1011_1011_1100_0111_0100_0101_0111_0000_0011_1101_1001_1000
```

This sequence is sent MSB first. This sequence can be represented as either:

- 0x49CF9046 A9B4A161 97F5B8C7 45703D98 transmitted MSB first.
- 0x19BC0EA2 E3DDAFE9 86852D95 6209F392 transmitted LSB first.

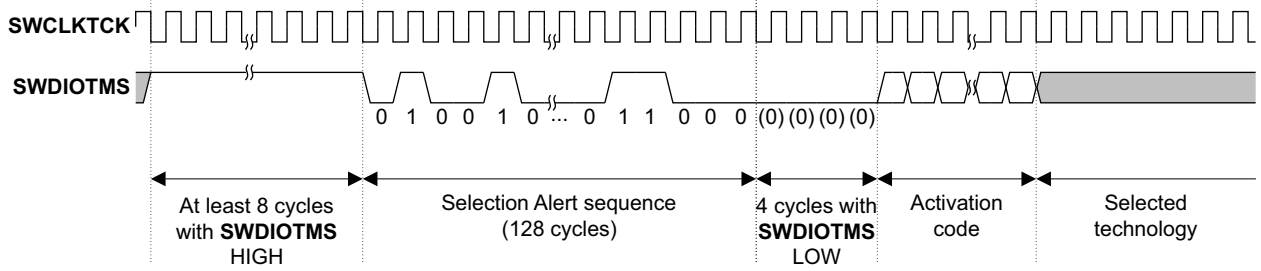

Figure B5-9 Selection Alert sequence

Note

The Selection Alert sequence can be generated by implementing a *Linear Feedback Shift Register (LFSR)* implementing feedback on bits 6, 5, 3 and 0, starting in the state 0b1001001 and shifting out one bit from bit 0 each cycle. The sequence starts with a zero start bit and continues with the output of the LFSR.

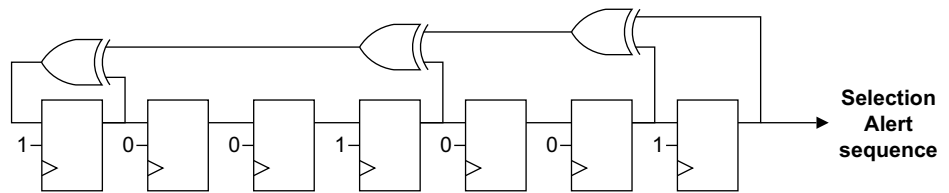

Figure B5-10 LFSR for generating Selection Alert sequence

The value of the activation code depends on whether SWD or JTAG operation is to be requested. Table B5-2 defines the activation codes that a debugger must use for JTAG devices, SW-DP devices, and SWJ-DP devices. These sequences are sent MSB first.

Table B5-2 Activation codes

Activation code	Value, MSB first	Devices activated				Protocol selected
		Other JTAG	ADI Debug Ports			
			JTAG	SW	SWJ	
JTAG-Serial	0b0000_0000_0000	Yes	Yes	No	Yes	JTAG
Arm CoreSight SW-DP	0b0101_1000	No	No	Yes	Yes	SWD
Arm CoreSight JTAG-DP	0b0101_0000	No	Yes	No	Yes	JTAG

JTAG online activation codes

For compatibility with other standards, all JTAG devices that implement dormant state using the ADIV6 defined selection alert sequence, must recognize other sequences as valid JTAG-Serial activation codes.

Figure B5-11 on page B5-145 shows, as a state diagram, the sequence that a JTAG device must recognize.

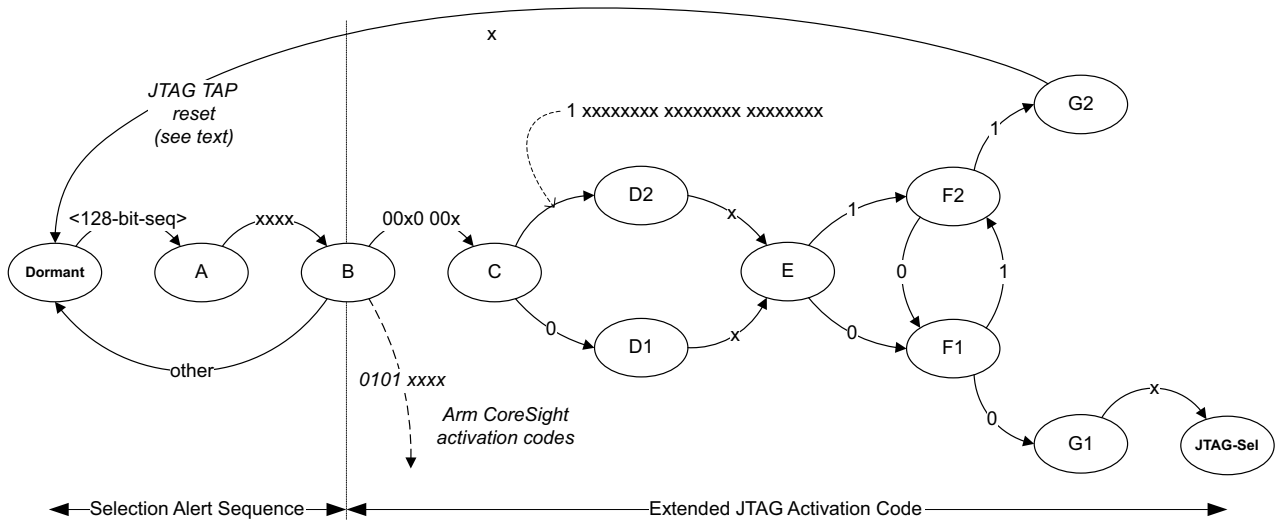

Figure B5-11 Dormant to JTAG state diagram

Each of the bit-strings that are shown in [Figure B5-11](#) are received MSB first. The transition out of state G2 requires a reset of the JTAG TAP, but otherwise returns to dormant state. For more information on this sequence, contact Arm.

Note

ADIV6 does not define any other activation codes, but also does not prohibit an implementation from recognizing other activation codes for compatibility with other standards. Implementations can also use alternative selection alert mechanisms. Debuggers can generate multiple selection alert sequences to alert multiple devices, and then use the common activation codes to select which devices to activate.

B5.4 Restrictions on switching between operating modes

A debugger must not mix JTAG-DP and SW-DP reads and writes of ADI registers in a single debug session. A single debug session is defined as from when a debugger connection is made with the system in a reset state through to the debugger connection being broken. At the start of a debug session, the state of the target is UNKNOWN.

Attempting to mix JTAG-DP and SW-DP reads and writes of ADI registers while any component of the ADI is active can have unpredictable results.

A powerup reset cycle might be required to reset the ADI implementation before a change in active Data Link protocol. However, this cycle is not required when switching between the active protocol and dormant state.

Part C

The Access Port

Chapter C1

About the AP

An ADI implementation can include multiple APs.

This chapter gives an overview of APs, and describes the features that must be implemented by every AP. It contains the following sections:

- [AP requirements on page C1-150.](#)
- [Selecting and accessing an AP on page C1-151.](#)
- [AP Programmers' Model Summary on page C1-152.](#)

The following chapters provide two AP definitions:

- [Chapter C2 The Memory Access Port.](#)
- [Chapter C3 The JTAG Access Port.](#)

Designers can use the ADI architecture specification to implement other APs.

C1.1 AP requirements

An ADI implementation can have multiple APs, and use a mixture of AP types.

———— **Note** —————

This specification permits an ADI implementation to include AP types that are not defined in the specification, even if such an AP is the only AP. A debugger must be able to detect any AP, and must ignore any AP that it does not recognize.

All APs must observe the following requirements:

- Every AP must implement an Identification Register as described in [AP Programmers' Model Summary on page C1-152](#). This identification model is required for implementations of the MEM-AP and JTAG-AP implementations that are defined by Arm, by any future Arm AP implementations, and by any APs that might be implemented by any third party.
- Any AP must support accesses by the implemented DP, as described in [Using the AP to access debug resources on page A1-31](#). A summary of how to access an AP is given in [Selecting and accessing an AP on page C1-151](#).
- For all APs, reserved registers must be RES0. This requirement applies to all APs, including any implemented by companies other than Arm.

The implementation of the ABORT mechanism is optional and IMPLEMENTATION DEFINED. Arm recommends that all APs implement the following functionality to handle abort requests:

- APs must be able to receive an abort request, and, on receipt of an abort request, respond to an outstanding transaction in finite time.
- An abort request from the DP is sent to all APs that are directly accessible by the DP, unless the AP is powered down.

There are no other requirements for APs in the ADIV6 specifications. All features that are provided by an AP can be IMPLEMENTATION DEFINED.

C1.2 Selecting and accessing an AP

Any APACC request to a MEM-AP, a JTAG-AP, or an AP not defined by this specification must be answered by the DP according to the following addressing scheme:

- The value of the `SELECT.ADDR` and `SELECT1.ADDR` fields must be used to select an AP, and which four-register bank of AP registers in the selected AP is accessed.
- The `A[3:2]` field that is passed in the APACC access must be used to select the AP register within the selected four-register bank.
- The `RnW` field for the APACC access must be used to determine whether the AP register access is a read access or a write access.

For detailed information about DP support for APACC accesses, see [Chapter B3 The JTAG Debug Port](#) and [Chapter B4 The Serial Wire Debug Port](#).

Examples of implementations of APACC accesses are shown in [Figure C2-1 on page C2-173](#) for a MEM-AP, and [Figure C3-1 on page C3-244](#) for a JTAG-AP.

C1.2.1 Stalling accesses

AP interfaces can support stalling accesses, which enable the AP to be connected to slow devices, such as a memory system or a long JTAG scan chain. In this way, the AP is in a pending state, and the access does not have to complete within a fixed number of cycles, which is important because often an AP access cannot complete until the associated memory access or JTAG scan has completed. For more information, see:

- [Stalling accesses on page C2-181](#), for stalling accesses to a MEM-AP.
- [Stalling accesses on page C3-250](#), for stalling accesses to a JTAG-AP.

C1.3 AP Programmers' Model Summary

This section describes the APv2 programmers' model, which must be implemented by all APs in an ADIV6 implementation.

An APv2 AP is a Class 0x9 CoreSight component with a register map of 4KB. A common programmers' model for all APv2 APs is defined in [Table C1-1](#). For information about the programmers' model for specific AP implementations, see [Chapter C2 The Memory Access Port](#) and [Chapter C3 The JTAG Access Port](#).

Table C1-1 Common APv2 programmers' model

Offset	Type	Name	Description
Area that is defined by the AP			
0x000 - 0xDF8	-	-	IMPLEMENTATION DEFINED
AP Identification			
0xDFC	RO	IDR	Identification Register.
Area that is defined by the AP			
0xE00 - 0xEFC	-	-	IMPLEMENTATION DEFINED
CoreSight management registers			
0xF00	RW	ITCTRL	Integration Mode Control Register.
0xF04 - 0xF9C	-	-	RES0.
0xFA0	RW	CLAIMSET	Claim Tag Registers.
0xFA4	RW	CLAIMCLR	
0xFA8	RO	DEVAFF0	Device Affinity Registers.
0xFAC	RO	DEVAFF1	
0xFB0	WO	LAR	Lock Access and Lock Status Registers.
0xFB4	RO	LSR	
0xFB8	RO	AUTHSTATUS	Authentication Status Register.
0xFBC	RO	DEVARCH	Device Architecture Register.
0xFC0	RO	DEVID2	Device ID Registers.
0xFC4	RO	DEVID1	
0xFC8	RO	DEVID	Device ID Register.
0xFCC	RO	DEVTYPE	Device Type Register.
0xFD0 - 0xFDC	RO	PIDR4-PIDR7	Peripheral Identification Registers.
0xFE0 - 0xFEC	RO	PIDR0-PIDR3	
0xFF0 - 0xFFC	RO	CIDR0-CIDR3	Component Identification Registers.

C1.4 AP Register Descriptions

C1.4.1 AUTHSTATUS, Authentication Status Register

The **AUTHSTATUS** characteristics are:

Purpose

Reports the required security level and status of the authentication interface. Where functionality changes on a given security level, the change in status must be reported in this register.

The effect of each debug level being enabled or disabled is specific to each AP.

Usage constraints

AUTHSTATUS is accessible as follows:

Default
RO

Configurations

Included in all implementations.

Attributes

A 32-bit register.

Field Descriptions

The **AUTHSTATUS** bit assignments are:

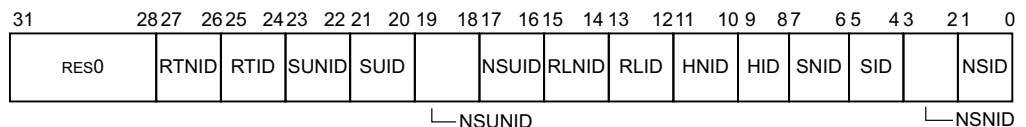

Bits[31:28]

RES0. For more information, see *Arm® CoreSight™ Architecture Specification*.

RTNID, bits[27:26]

Root non-invasive debug. For more information, see *Arm® CoreSight™ Architecture Specification*.

RTID, bits[25:24]

Root invasive debug. For more information, see *Arm® CoreSight™ Architecture Specification*.

SUNID, bits[23:22]

Secure Unprivileged non-invasive debug. For more information, see *Arm® CoreSight™ Architecture Specification*.

SUID, bits[21:20]

Secure Unprivileged invasive debug. For more information, see *Arm® CoreSight™ Architecture Specification*.

NSUNID, bits[19:18]

Non-secure Unprivileged non-invasive debug. For more information, see *Arm® CoreSight™ Architecture Specification*.

NSUID, bits[17:16]

Non-secure Unprivileged invasive debug. For more information, see *Arm® CoreSight™ Architecture Specification*.

RLNID, bits[15:14]

Realm non-invasive debug. For more information, see *Arm® CoreSight™ Architecture Specification*.

RLID, bits[13:12]

Realm invasive debug. For more information, see *Arm® CoreSight™ Architecture Specification*.

HNID, bits[11:10]

Hypervisor non-invasive debug. For more information, see *Arm® CoreSight™ Architecture Specification*.

HID, bits[9:8]

Hypervisor invasive debug. For more information, see *Arm® CoreSight™ Architecture Specification*.

SNID, bits[7:6]

Secure non-invasive debug. For more information, see *Arm® CoreSight™ Architecture Specification*.

SID, bits[5:4]

Secure invasive debug. For more information, see *Arm® CoreSight™ Architecture Specification*.

NSNID, bits[3:2]

Non-secure non-invasive debug. For more information, see *Arm® CoreSight™ Architecture Specification*.

NSID, bits[1:0]

Non-secure invasive debug. For more information, see *Arm® CoreSight™ Architecture Specification*.

Accessing AUTHSTATUS

[AUTHSTATUS](#) can be accessed at the following address:

Offset

0xFB8

C1.4.2 CIDR0-CIDR3, Component Identification Registers

This section describes the bit assignments for AP components. For a full description of the CIDR registers, see CIDR0-CIDR3 registers in *Arm® CoreSight™ Architecture Specification*.

The [CIDR0-CIDR3](#) characteristics are:

Purpose

Provide information to identify a CoreSight component.

Usage constraints

CIDR0-CIDR3 are accessible as follows:

Default

RO

Configurations

Included in all implementations.

Attributes

Four 32-bit management registers.

Field Descriptions

The CIDR0-CIDR3 bit assignments are:

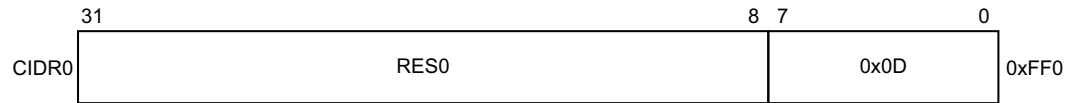
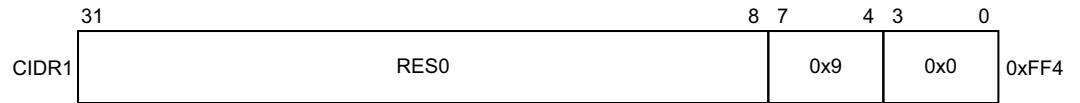
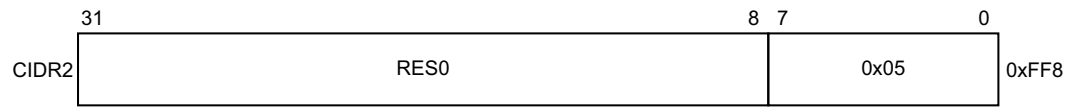
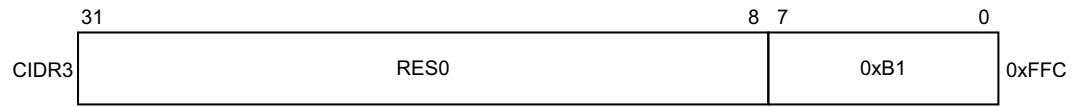

CIDR3 bits[31:8]

RES0.

PRMBL_3, CIDR3 bits[7:0]

0xB1.

CIDR2 bits[31:8]

RES0.

PRMBL_2, CIDR2 bits[7:0]

0x05.

CIDR1 bits[31:8]

RES0.

CLASS, CIDR1 bits[7:4]

0x9 CoreSight component.

PRMBL_1, CIDR1 bits[3:0]

0x0.

CIDR0 bits[31:8]

RES0.

PRMBL_0, CIDR0 bits[7:0]

0x0D.

Accessing CIDR0-CIDR3 registers

CIDR0-CIDR3 can be accessed at the following address:

Offset			
CIDR0	CIDR1	CIDR2	CIDR3
0xFF0	0xFF4	0xFF8	0xFFC

C1.4.3 CLAIMSET and CLAIMCLR, Claim Tag Set Register and Claim Tag Clear Register

The CLAIMSET and CLAIMCLR characteristics are:

Purpose

The claim tags are used to communicate between different debug agents and to claim usage of an APv2 AP.

Often there are several debug agents that must cooperate to control the resources that the CoreSight components make available. For example, an external debugger and a debug monitor running on the target might both require control of the breakpoint resources of a PE. It is important that a debug agent does not reprogram debug resources that another debug agent is using.

The claim tag registers provide various bits that can be separately set and cleared to indicate whether functionality is in use by a debug agent. All debug agents must implement a common protocol to use these bits.

For an AP, Arm recommends that a minimum of two claim tag bits are implemented, with the following usage:

- Claim tag bit 0 is used by self-hosted software to indicate that it is using the AP.
- Claim tag bit 1 is used by an external debugger to indicate that it is using the AP.

Arm recommends implementing claim tag 0 for use by self-hosted software to indicate that it is using the AP. When an agent that uses claim tag 0 is setting claim tag 0, it must verify that claim tag 1 is not set. If claim tag 1 is set, the agent must clear claim tag 0. The debug agent must only use the AP if only its claim tag is set. When a debug agent finishes using the AP, it must clear its claim tag.

Arm recommends implementing claim tag 1 for use by an external debugger to indicate that it is using the AP. When an agent that uses claim tag 1 is setting claim tag 1, it must verify that claim tag 0 is not set. If claim tag 0 is set, the agent must clear claim tag 1. The debug agent must only use the AP if only its claim tag is set. When a debug agent finishes using the AP, it must clear its claim tag.

For details about how to set and clear the claim tags, see the field descriptions.

Note

The recommended use of the claim tag bits may vary by debug component. Refer to the technical documentation of the specific debug component for the recommended usage. For PE debug components, see *ARM® Debug and Trace Configuration and Usage Models* (ARM DEN 0034A).

Usage constraints

CLAIMSET and CLAIMCLR are accessible as follows:

CLAIMSET	CLAIMCLR
RW	RW

Configurations

Included in all implementations.

Attributes

Two 32-bit registers.

Field Descriptions

The CLAIMSET and CLAIMCLR bit assignments are:

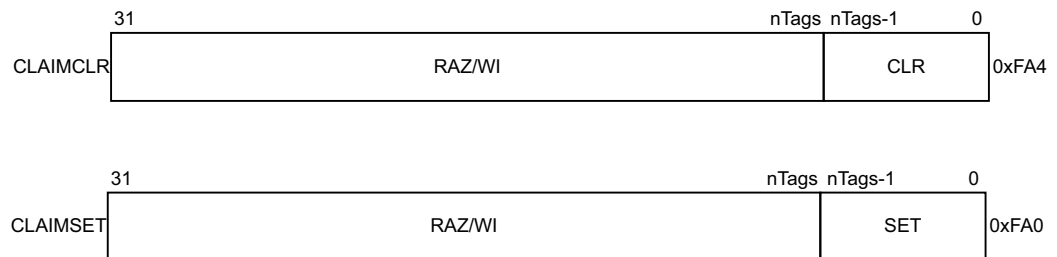

CLAIMCLR bits[31:nTags]

RAZ/WI

CLR, CLAIMCLR bits[nTags-1:0]

The size of this field, nTags, is IMPLEMENTATION DEFINED, and equals the number of bits set in CLAIMSET.

Allowed values of CLR[n] are:

- Write 0** No effect.
- Write 1** Clear the claim tag for bit[n].
- Read 0** The claim tag bit is not set.
- Read 1** The claim tag bit is set.

CLAIMSET bits[31:nTags]

RAZ/WI

SET, CLAIMSET bits[nTags-1:0]

The size of this field, nTags, is IMPLEMENTATION DEFINED, and equals the number of claim bits that are implemented.

Permitted values of SET[n] are:

- Write 0** No effect.
- Write 1** Set the claim tag for bit[n].
- Read 0** The claim tag that is represented by bit[n] is not implemented.
- Read 1** The claim tag that is represented by bit[n] is implemented.

Accessing CLAIMSET and CLAIMCLR

CLAIMSET and CLAIMCLR can be accessed at the following addresses:

Offset	
CLAIMSET	CLAIMCLR
0xFA0	0xFA4

C1.4.4 DEVAFF0-DEVAFF1, Device Affinity Registers

The DEVAFF0-DEVAFF1 characteristics are:

Purpose

Enables a debugger to determine whether two components have an affinity with each other.

Usage constraints

DEVAFF0-DEVAFF1 are accessible as follows:

Default
RO

Configurations

Included in all implementations.

Attributes

Two 32-bit registers.

Field Descriptions

The DEVAFF0-DEVAFF1 bit assignments are:



DEVAFF0, bits[31:0]

DEVAFF1, bits[31:0]

IMPLEMENTATION DEFINED.

Accessing DEVAFF0-DEVAFF1

The [DEVAFF0-DEVAFF1](#) registers can be accessed at the following addresses:

Offset	
DEVAFF0	DEVAFF1
0xFA8	0xFAC

C1.4.5 DEVARCH, Device Architecture Register

The [DEVARCH](#) characteristics are:

Purpose

Identifies the architect and architecture of a CoreSight component.

Usage constraints

[DEVARCH](#) is accessible as follows:

Default
RO

Configurations

Included in all implementations.

Attributes

A 32-bit register.

Field Descriptions

The [DEVARCH](#) bit assignments are:

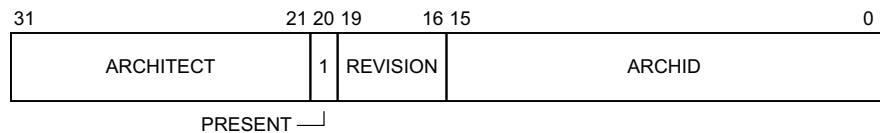

ARCHITECT, bits[31:21]

0x23B Arm.

PRESENT, bit[20]

0b1 Present.

REVISION, bits[19:16]

0x0 Revision 0.

ARCHID, bits[15:0]

The following values are defined for APv2 architectures that are defined by Arm:

0x0A17 MEM-AP.
0x0A27 JTAG-AP.
0x0A47 Unknown AP.

If this value of ARCHID is found by a debugger, the debugger must use the IDR register in the AP to determine more information about the AP. This value might occur if an AP from a previous ADI version is adapted to appear as an APv2 AP.

Accessing DEVARCH

DEVARCH can be accessed at the following address:

Offset

0xFBC

C1.4.6 DEVID, Device Configuration Register

The DEVID characteristics are:

Purpose

Indicates the capabilities of the component.

Usage constraints

DEVID is accessible as follows:

Default

RO

Configurations

Included in all implementations.

Attributes

A 32-bit register.

Field Descriptions

The DEVID bit assignments are:

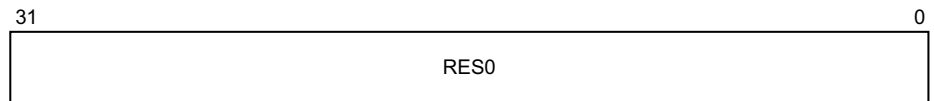

Bits[31:0]

RES0.

Accessing DEVID

DEVID can be accessed at the following address:

Offset

0xFC8

C1.4.7 DEVID1-DEVID2, Device Configuration Registers

The [DEVID1-DEVID2](#) characteristics are:

Purpose

Indicates the capabilities of the component.

Usage constraints

[DEVID1-DEVID2](#) are accessible as follows:

Default
RO

Configurations

Included in all implementations.

Attributes

Two 32-bit registers.

Field Descriptions

The [DEVID1-DEVID2](#) bit assignments are:

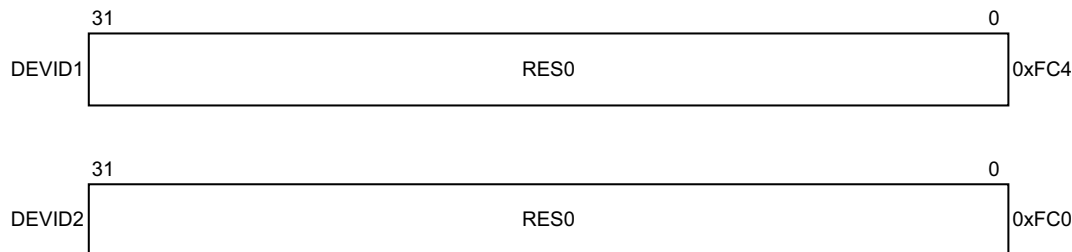

DEVID1, bits[31:0]

DEVID2, bits[31:0]

RES0.

Accessing DEVID1-DEVID2

[DEVID1-DEVID2](#) can be accessed at the following addresses:

Offset	
DEVID1	DEVID2
0xFC4	0xFC0

C1.4.8 DEVTYPE, Device Type Register

The [DEVTYPE](#) characteristics are:

Purpose

A debugger can use [DEVTYPE](#) to obtain information about a component that has an unrecognized Part number.

Usage constraints

DEVTYPE is accessible as follows:

Default

RO

Configurations

Included in all implementations.

Attributes

A 32-bit register.

Field Descriptions

The **DEVTYPE** bit assignments are:

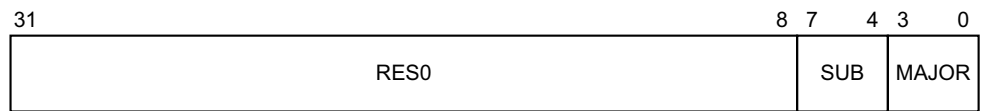

Bits[31:8]

RES0.

SUB, bits[7:4]

0x0 Other, undefined.

MAJOR, bits[3:0]

0x0 Miscellaneous.

Accessing DEVTYPE

DEVTYPE can be accessed at the following address:

Offset

0xFCC

C1.4.9 IDR, Identification Register

The **IDR** characteristics are:

Purpose

Identifies the Access Port.

Usage constraints

The value of **IDR** after a reset is IMPLEMENTATION DEFINED.

IDR is accessible as follows:

Default

RO

Configurations

Included in all implementations.

APs that comply with the ADiv6 specification must implement the JEP106 code and provide a value in the REVISION and CLASS fields.

Attributes

A 32-bit read-only register.

Field Descriptions

The **IDR** bit assignments are:

31	28 27	17 16	13 12	8 7	4 3	0
REVISION	DESIGNER	CLASS	RES0	VARIANT	TYPE	

REVISION, bits[31:28]

Starts at 0x0 for the first implementation of an AP design, and increments by one on each major or minor revision of the design. Major design revisions introduce functionality changes, minor revisions are bug fixes.

DESIGNER, bits[27:17]

Code that identifies the designer of the AP.

This field indicates the designer of the AP and not the implementer, except where the two are the same. To obtain a number, or to see the assignment of these codes, contact JEDEC <http://www.jedec.org>.

A JEDEC code takes the following form:

- A sequence of zero or more numbers, all having the value 0x7F.
- A following 8-bit number, that is not 0x7F, and where bit[7] is an odd parity bit. For example, Arm® Limited is assigned the code 0x7F 0x7F 0x7F 0x7F 0x3B.

The encoding that is used in the **IDR** is as follows:

- The JEP106 continuation code, **IDR** bits[27:24], is the number of times that 0x7F appears before the final number. For example, for Arm Limited this field is 0x4.
- The JEP106 identification code, **IDR** bits[23:17], equals bits[6:0] of the final number of the JEDEC code. For example, for Arm Limited this field is 0x3B.

———— Note ————

The JEP106 codes are assigned by JEDEC to identify the manufacturer of a device. However, in the AP Identification register they identify the designer of the AP.

An implementer of an Arm MEM-AP or JTAG-AP must not change these AP Identification Register values.

———— Note ————

For backwards compatibility, debuggers must treat an AP that returns a JEP106 field of zero as an AP designed by Arm. This encoding was used in early implementations of the ADI. In such an implementation, the REVISION and CLASS fields are also RAZ.

APs that comply with the ADiv6 specification must use the JEP106 code and provide a value in the REVISION and CLASS fields.

CLASS, bits[16:13]

Defines the class of the AP. If an AP follows a programmers' model that is defined as part of the ADiv6 specification or extensions to it, it belongs to a class. This field can have the following values:

- 0b0000 No defined class.
- 0b1000 MEM-AP See [Chapter C2 The Memory Access Port](#).

Bits[12:8] Reserved, RES0. This field is reserved for future ID register fields. If a debugger reads a non-zero value in this field, it must treat the AP as unidentifiable.

VARIANT, bits[7:4]

Together with the TYPE field, this field identifies the AP implementation. VARIANT differentiates AP implementations that have the same value of TYPE.

Each AP designer must maintain their own list of implementations and associated AP Identification codes.

TYPE, bits[3:0]

Indicates the type of bus, or other connection, that connects to the AP. Table C1-2 lists the possible values of the Type field for an AP designed by Arm. It also shows the value of the CLASS field, which corresponds to bits[16:13] of the IDR, for each value of TYPE.

Together with the VARIANT field, this field identifies the AP implementation. AP implementations that have the same value of TYPE are differentiated by their VARIANT value.

Each AP designer must maintain their own list of implementations and associated AP Identification codes.

Table C1-2 AP Identification types for an AP designed by Arm

TYPE	Connection to AP	CLASS	Notes
0x0	JTAG connection	0b0000	VARIANT field, bits [7:4] of IDR, must be non-zero.
0x1	AMBA AHB3 bus	0b1000	-
0x2	AMBA APB2 or APB3 bus	0b1000	-
0x4	AMBA AXI3 or AXI4 bus, with optional ACE-Lite support	0b1000	-
0x5	AMBA AHB5 bus	0b1000	-
0x6	AMBA APB4 or APB5 bus	0b1000	-
0x7	AMBA AXI5 bus	0b1000	-
0x8	AMBA AHB5 with enhanced HPROT	0b1000	-
Other	Reserved	-	-

Accessing IDR

IDR can be accessed at the following address:

Offset
0xDFC

C1.4.10 ITCTRL, Integration Mode Control Register

The ITCTRL characteristics are:

Purpose

A component can use ITCTRL to dynamically switch between functional mode and integration mode.

In integration mode, topology detection is enabled.

Usage constraints

After switching to integration mode and performing integration tests or topology detection, reset the system to ensure correct behavior of CoreSight and other connected system components.

[ITCTRL](#) is accessible as follows:

Default

RW

Configurations

Included in all implementations.

Attributes

A 32-bit register.

Field Descriptions

The [ITCTRL](#) bit assignments are:

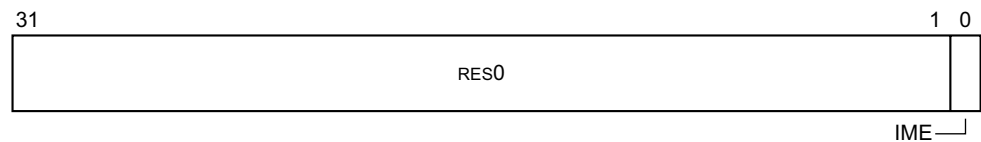

Bits[31:1]

RES0.

IME, bits[0]

Permitted values of IME are:

- 0 The component must enter functional mode.
- 1 The component must enter integration mode, and enable support for topology detection and integration testing.

When no integration functionality is implemented, this field is RES0.

Accessing ITCTRL

[ITCTRL](#) can be accessed at the following address:

Offset

0xF00

C1.4.11 LAR and LSR, Lock Access Register and Lock Status Register

The [LAR and LSR](#) characteristics are:

Purpose

The Software Lock mechanism prevents accidental access to the registers of CoreSight components. For an AP, the lock mechanism is not implemented.

Usage constraints

LAR and LSR are accessible as follows:

LAR	LSR
WO	RO

Configurations

Included in all implementations.

Attributes

A set of 32-bit registers.

Field Descriptions

The LAR and LSR bit assignments are:

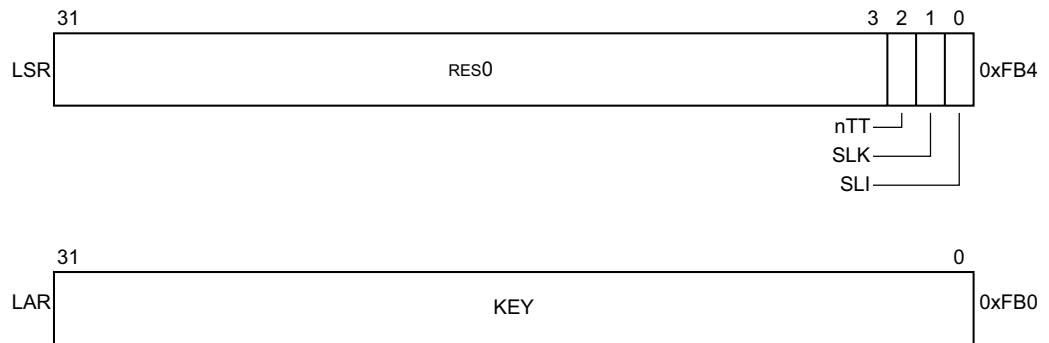

LSR, bits[31:3]

RES0.

nTT, LSR bit[2]

RAZ.

SLK, LSR bit[1]

RAZ.

SLI, LSR bit[0]

RAZ.

KEY, LAR bits[31:0]

WI.

Accessing LAR and LSR

LAR and LSR can be accessed at the following addresses:

Offset	
LAR	LSR
0xFB0	0xFB4

C1.4.12 PIDR0-PIDR7, Peripheral Identification Registers

This section describes the bit assignments for AP components.

The [PIDR0-PIDR7](#) characteristics are:

Purpose

Provide information to identify a CoreSight component.

Usage constraints

[PIDR0-PIDR7](#) are accessible as follows:

Default
RO

Configurations

Included in all implementations.

Attributes

Eight 32-bit management registers.

Field Descriptions

The [PIDR0-PIDR7](#) bit assignments are:

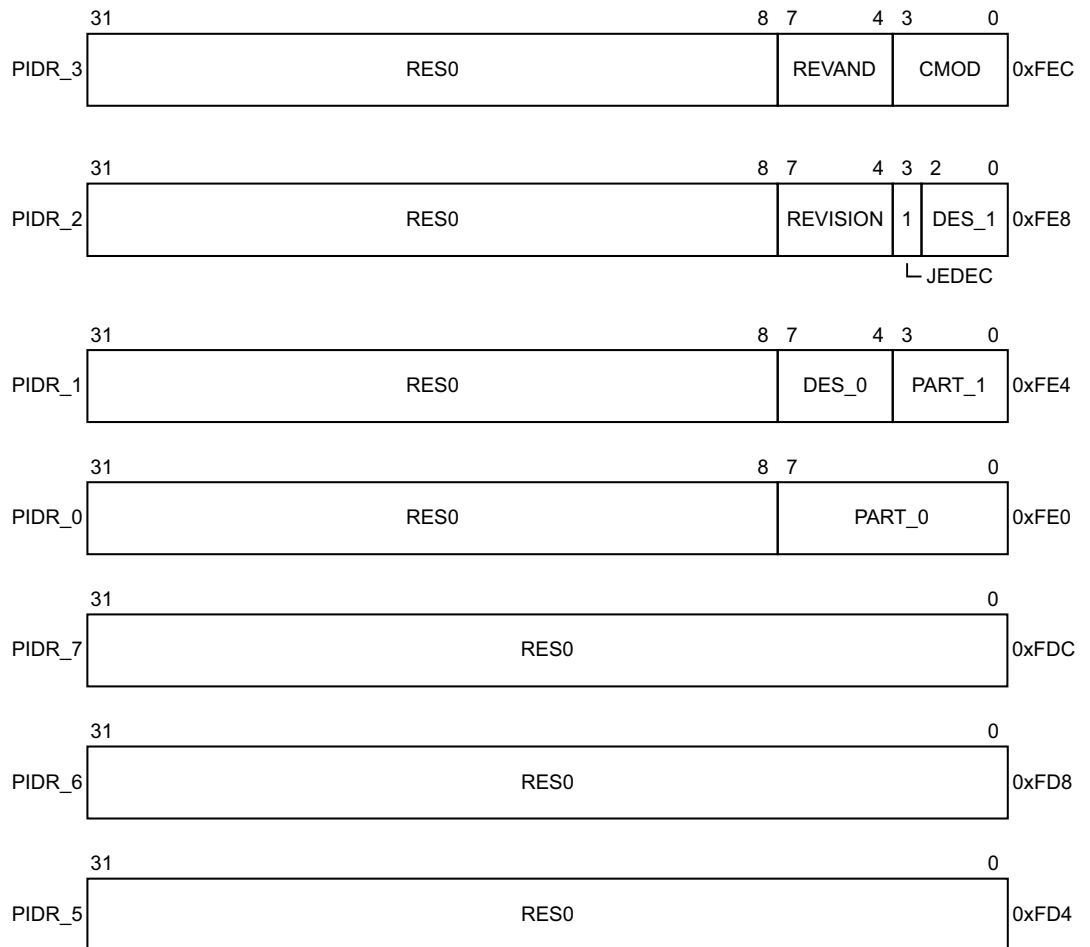



PIDR3 bits[31:8]

RES0.

REVAND, PIDR3 bits[7:4]

See register descriptions in PIDR0-PIDR7 in *Arm® CoreSight™ Architecture Specification*.

CMOD, PIDR3 bits[3:0]

See register descriptions in PIDR0-PIDR7 in *Arm® CoreSight™ Architecture Specification*.

PIDR2 bits[31:8]

RES0.

REVISION, PIDR2 bits[7:4]

See register descriptions in PIDR0-PIDR7 in *Arm® CoreSight™ Architecture Specification*.

JEDEC, PIDR2 bits[3]

0b1 A JEDEC value is used.

DES_1, PIDR2 bits[2:0]

See register descriptions in PIDR0-PIDR7 in *Arm® CoreSight™ Architecture Specification*.

PIDR1 bits[31:8]

RES0.

DES_0, PIDR1 bits[7:4]

See register descriptions in PIDR0-PIDR7 in *Arm® CoreSight™ Architecture Specification*.

PART_1, PIDR1 bits[3:0]

See register descriptions in PIDR0-PIDR7 in *Arm® CoreSight™ Architecture Specification*.

PIDR0 bits[31:8]

RES0.

PART_0, PIDR0 bits[7:0]

See register descriptions in PIDR0-PIDR7 in *Arm® CoreSight™ Architecture Specification*.

PIDR7 bits[31:0]

RES0.

PIDR6 bits[31:0]

RES0.

PIDR5 bits[31:0]

RES0.

PIDR4 bits[31:8]

RES0.

SIZE, PIDR4 bits[7:4]

See register descriptions in PIDR0-PIDR7 in *Arm® CoreSight™ Architecture Specification*.

DES_2, PIDR4 bits[3:0]

See register descriptions in PIDR0-PIDR7 in *Arm® CoreSight™ Architecture Specification*.

Accessing PIDR0-PIDR7 registers

[PIDR0-PIDR7](#) can be accessed at the following address:

Offset							
PIDR0	PIDR1	PIDR2	PIDR3	PIDR4	PIDR5	PIDR6	PIDR7
0xFE0	0xFE4	0xFE8	0xFEC	0xFD0	0xFD4	0xFD8	0xFDC

Chapter C2

The Memory Access Port

This chapter describes the implementation of the *Memory Access Port* (MEM-AP), and how a MEM-AP connects the DP to a debug component.

This chapter contains the following sections:

- [About the MEM-AP on page C2-172.](#)
- [MEM-AP functions on page C2-177.](#)
- [Implementing a MEM-AP on page C2-192.](#)
- [MEM-AP examples of pushed-verify and pushed-compare on page C2-196.](#)
- [MEM-AP programmers' model on page C2-198.](#)
- [MEM-AP register descriptions on page C2-201.](#)

For information that applies to all APs, see [Chapter C1 About the AP.](#)

C2.1 About the MEM-AP

A MEM-AP provides access to a memory-mapped abstraction of a set of debug resources in the system being debugged.

A MEM-AP provides a window into a different memory system without using large amounts of address space in the originating memory system. The following implementations are examples of this principle:

- Allowing a processor to access the address of another processor.
- Allowing a processor with a 32-bit address space to access the address space of a processor with a larger address space.

This specification is for MEM-APs using the APv2 architecture. This specification defines the MEM-AP as a Class 0x9 CoreSight component with a 4KB register map.

———— Note ————

Access to a MEM-AP might only access a register within the MEM-AP, without generating a memory access to the system being debugged.

C2.1.1 The programmers' model for debug register access

The programmers' model for debug registers is a memory map. Although use of a memory bus system is not required, this abstraction enables the same programming model to be used for accessing debug registers and system memory. With this model, the debug registers might be implemented as a peripheral within the system memory space.

The debug registers in a debug component occupy one or more 4KB blocks of address space. A system might contain several such debug components.

Although the architecture specification permits a debug component to implement multiple 4KB blocks, most components implement a single block.

———— Note ————

Although a component can occupy only 4KB of address space, Arm recommends that the base address of each component is aligned to the largest translation granule supported by any processor that can access the component. For an Armv8-A or Armv9-A processor, the granule size can be up to 64KB.

Debug register files

A 4KB block of address space accessible from an AP can be referred to as a debug register file. A single AP can access multiple debug register files. There is a base standard for debug register file identification, and debuggers must be able to recognize and ignore register files that they do not support.

A single MEM-AP can access a mixture of system memory and debug register files.

ROM Tables

A ROM Table is a special case of a debug register file. It is a 4KB memory block that identifies a system.

If there is only one debug component in the system to which the MEM-AP is connected, the ROM Table is optional. However, because the ROM Table contains a unique system identifier that identifies the complete SoC to the debugger, an implementation might choose to include a ROM Table even if there is only one other debug component in the system.

When a system includes more than one debug component it must include a ROM Table.

[Chapter D1 About ROM Tables](#) describes ROM Tables.

C2.1.2 Selecting and accessing the MEM-AP

Figure C2-1 shows the implementation of a MEM-AP, and how the MEM-AP connects the DP to the debug components. Two example debug components are shown, a processor core and an ETM, together with a ROM Table. APACC accesses to the DP are passed to the MEM-AP.

The method of selecting an AP, and selecting a specific register within the selected AP, is the same for MEM-APs and JTAG-APs. See also [Selecting and accessing an AP on page C1-151](#).

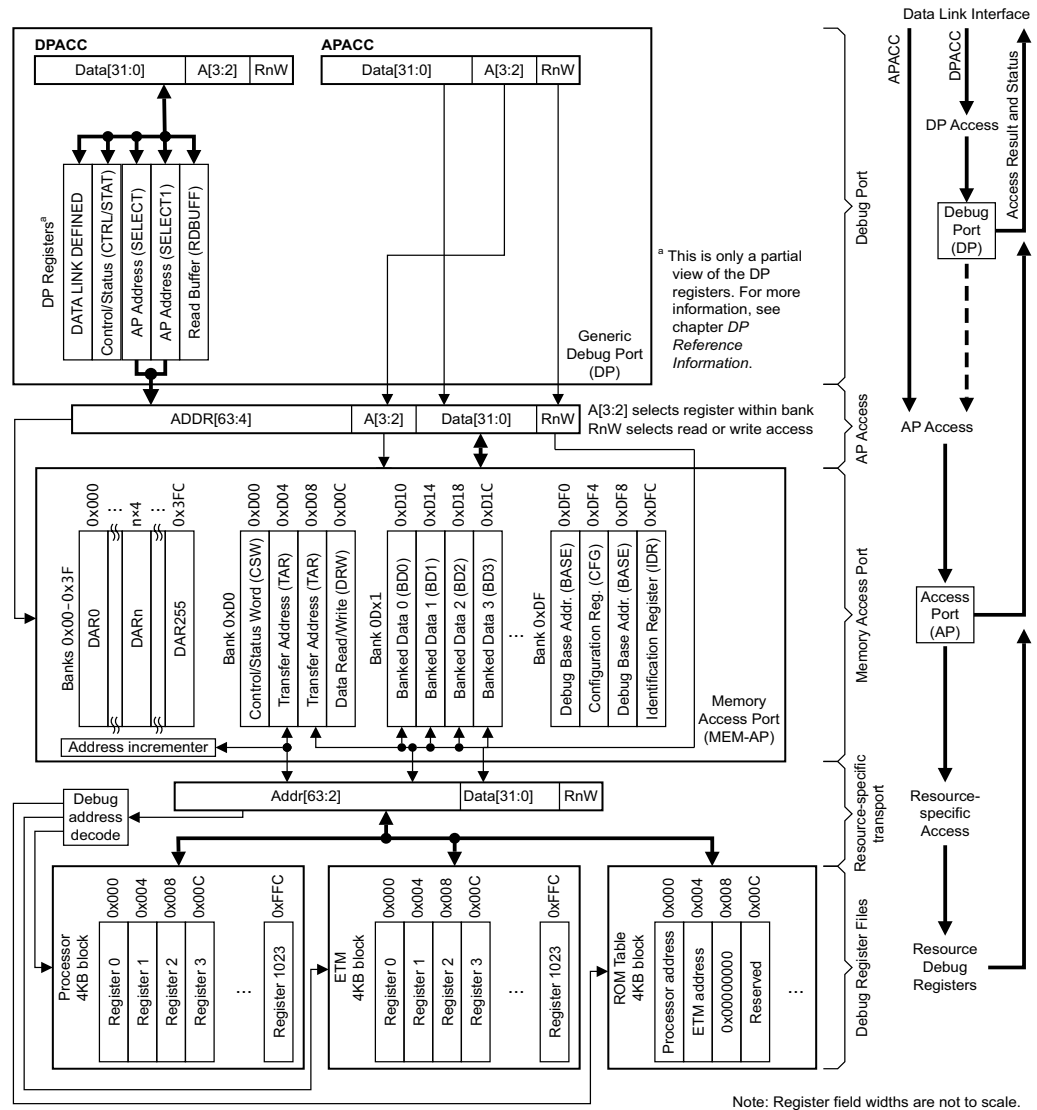

Figure C2-1 MEM-AP connecting the DP to debug components

C2.1.3 The MEM-AP registers

The MEM-AP registers, and the memory map of the MEM-AP, are described in detail in [MEM-AP register descriptions on page C2-201](#). However, you require a basic knowledge of the functions of these registers to understand the operation of the MEM-AP. The MEM-AP registers are shown in [Figure C2-1](#):

Control/Status Word register, CSW

The CSW holds control and status information for the MEM-AP.

Transfer Address Register, TAR

The **TAR** holds the address for the next access to the memory system, or set of debug resources, which are connected to the MEM-AP. The MEM-AP can be configured so that the **TAR** is incremented automatically after each memory access. Reading or writing to the **TAR** does not cause a memory access.

Transfer Response Register, TRR

The TRR captures whether an error response was received during a transaction, and can be used to clear any logged responses.

The TRR is implemented when Error response handling version 1 is implemented, see [CFG, Configuration register on page C2-209](#).

Data Read/Write register, DRW

The **DRW** is used for memory accesses:

- Writing to the **DRW** initiates a write to the address specified by the **TAR**.
- Reading from the **DRW** initiates a read from the address that is specified by the **TAR**. When the read access completes, the value is returned from the **DRW**.

Direct Access Registers, DAR0-DAR255

The 256 Direct Access Registers, DAR0-DAR255, provide direct read or write access to a 1KB block of memory, starting at the address that is specified in the **TAR**. Accessing DAR0-DAR255 accesses $((\text{TAR}[31:10] \ll 10) + (n \times 4))$ in memory. Any byte or halfword accesses are not supported by DARx registers.

The value in **TAR**[9:0] is ignored in constructing the access address.

Banked Data Registers, BD0 to BD3

The Banked Data Registers, **BD0-BD3**, provide direct read or write access to a block of four words of memory, starting at the address that is specified in the **TAR**. Accessing BD<n> accesses $((\text{TAR}[31:4] \ll 4) + (n \times 4))$ in memory.

The value in **TAR**[3:0] is ignored in constructing the access address:

- The values of bits[3:2] of the access address depend solely on which of the four banked data registers is being accessed.
- Bits[1:0] of the access are always zero.

Configuration register, CFG

The **CFG** register hold information about the configuration of the MEM-AP and whether Realm Management Extension is supported.

Debug Base Address register, BASE

The **BASE** register is a pointer into the connected memory system. It points to one of:

- The start of a set of debug registers for the single connected debug component.
- The start of a ROM Table that describes the connected debug components.

Identification Register, IDR

The **IDR** identifies the MEM-AP.

————— **Note** —————

This brief summary of the MEM-AP registers does not include cross-references to the detailed register descriptions. For more information about these registers, see [MEM-AP register descriptions on page C2-201](#).

C2.1.4 MEM-AP register accesses and memory accesses

Note

In this section, an access to the debug resources is described as a memory access.

This section summarizes all the possible APACC accesses to a MEM-AP, and covers accesses to each of the MEM-AP registers. These accesses are summarized in the following sections:

- [Accesses that do not initiate a memory access.](#)
- [Accesses that initiate a memory access.](#)
- [Accesses that support pushed transactions and the transaction counter on page C2-176.](#)

Accesses that do not initiate a memory access

APACC accesses to the following MEM-AP registers do not cause a memory access:

- The Control/Status Word register, [CSW](#).
- The Transfer Address Register, [TAR](#).
- The Transfer Response Register, [TRR](#).
- The Tag 0 Transfer register, [T0TR](#).
- The Configuration register, [CFG](#).
- The Configuration register 1, [CFG1](#).
- The Debug Base Address register, [BASE](#).
- The MECID value register, [MECID](#).
- The Identification Register, [IDR](#).
- The CoreSight management registers, [ITCTRL](#), [CLAIMSET](#) and [CLAIMCLR](#), [DEVAFF0-DEVAFF1](#), [LAR](#) and [LSR](#), [AUTHSTATUS](#), [DEVARCH](#), [DEVID1-DEVID2](#), [DEVID](#), [DEVTYPE](#), [PIDR0-PIDR7](#), and [CIDR0-CIDR3](#).

Accesses that initiate a memory access

This section introduces the APACC accesses to MEM-AP registers that initiate one or more memory accesses. These APACC accesses are:

- Accesses to the [DRW](#) register. A memory access is initiated, using the address that is held in the [TAR](#).
- Accesses to one of the Banked Data Registers, [BD0-BD3](#).
The address that is used for the memory access depends on which Banked Data Register is accessed.
- Accesses to one of the Direct Access Registers, [DAR0-DAR255](#).
The address that is used for the memory access depends on which Direct Access Register is accessed.
- Accesses to the Memory Barrier Transfer register, [MBT](#).

However, if the MEM-AP implementation includes the Large Data Extension, and [CSW](#).Size specifies a transfer size that is larger than a word, some [DRW](#), [BD0-BD3](#), and [DAR0-DAR255](#) accesses do not initiate a memory access, see [DRW, Data Read/Write register on page C2-226](#) and [Accessing BD0-BD3 on page C2-207](#).

Sometimes, a single AP transaction initiates more than one memory access:

- When the transaction counter is set. See [The transaction counter on page B1-45](#).
- When packed transfers are supported and enabled and the transfer size is smaller than word. See [Packed transfers on page C2-187](#).

For more information, see [Packed transfers on page C2-187](#).

If an AP transaction initiates one or more memory accesses, the AP transaction does not complete until one of the following occurs:

- All the memory accesses complete successfully.

- A memory access terminates with an error response. In this case, any outstanding accesses to the debug component are abandoned.
- The AP accesses are aborted using the [ABORT](#) register, see also [MEM-AP response to an abort request through the DP ABORT register](#).

Accesses that support pushed transactions and the transaction counter

A MEM-AP supports pushed transactions and sequences of transactions to the following registers only:

- [DRW](#), Data Read/Write register.
- Banked Data registers 0-3, see [BD0-BD3, Banked Data registers](#) on page C2-206.
- Direct Access Registers, see [DAR0-DAR255, Direct Access registers](#) on page C2-219.

For more information, see:

- [Pushed-compare and pushed-verify operations](#) on page B1-46.
- [The transaction counter](#) on page B1-45.

C2.1.5 MEM-AP response to an abort request through the DP ABORT register

———— Note ————

From ADIv6.0, which uses the DPv3 architecture, the implementation of the ABORT mechanism is OPTIONAL and IMPLEMENTATION DEFINED. See also [DP architecture version 3 \(DPv3\) address map](#) on page B2-51.

If the AP supports the abort mechanism, and the [ABORT](#) register signals an abort request while a memory access is in progress:

- The MEM-AP must respond to the outstanding transaction in finite time.
- Arm recommends that the MEM-AP sends an error response when responding to the outstanding transaction. This error response is always sent, regardless of the setting of [CSW.ERRNPASS](#).
- If the [TRR](#) is implemented, [TRR.ERROR](#) is set to 0b1. If [CFG.ERR](#) has a value of 0b0001, the [TRR](#) is implemented.
- [CSW.TrInProg](#) is set to 0b1, and remains at this value until any outstanding output transactions are complete.

After an abort, the MEM-AP is in an UNKNOWN state and it is IMPLEMENTATION DEFINED which MEM-AP registers are accessible. Arm recommends that the MEM-AP registers that are not directly related to an outstanding transaction remain accessible, to allow a debug agent to diagnose the cause of the problem that caused the abort request to be issued.

If the MEM-AP receives an abort request while there is no outstanding transaction to the MEM-AP, the MEM-AP must ignore the abort request.

If the [ABORT](#) register is implemented in the DP, it is optional whether an outstanding transaction to an AP is aborted. If a transaction in progress cannot be aborted, it is permitted for access to a component to be impossible without resetting the system.

Arm recommends that all APs implement the ability to receive an abort request.

For more details on the abort mechanism and the [ABORT](#) register, see [DP architecture version 3 \(DPv3\) address map](#) on page B2-51 and [ABORT, Abort register](#) on page B2-53.

C2.2 MEM-AP functions

This section describes the functions of a MEM-AP. These functions are controlled by the MEM-AP registers, as described in [MEM-AP register descriptions on page C2-201](#).

The following sections describe functions that a MEM-AP must support:

- [Enabling access to the connected debug device or memory system](#).
- [Auto-incrementing the Transfer Address Register \(TAR\) on page C2-179](#).
- [Stalling accesses on page C2-181](#).
- [Error Handling on page C2-182](#).
- [Response to debug component errors on page C2-184](#).

The following sections describe functions for which it is IMPLEMENTATION DEFINED whether a particular MEM-AP supports them:

- [Variable access size for memory accesses on page C2-185](#).
- [Byte lanes on page C2-186](#).
- [Packed transfers on page C2-187](#).
- [Completer Memory Ports on page C2-188](#).
- [Twin MEM-APs on page C2-189](#).
- [Software access control on page C2-190](#).

———— Note ————

Some of the IMPLEMENTATION DEFINED functions are inter-dependent. Their dependencies are summarized in [MEM-AP implementation requirements on page C2-193](#).

C2.2.1 Enabling access to the connected debug device or memory system

This section describes the authentication interfaces that can be used with ADI:

- [Authentication interface of an APv2 MEM-AP](#).
- [Authentication interface of a legacy APv1 MEM-AP](#).

For a full description of the CoreSight Authentication interface, see the *Authentication Interface* chapter in the *Arm® CoreSight™ Architecture Specification*.

For Armv7-A or Armv7-R PEs, Arm strongly recommends that the MEM-AP interface does not use the same authentication signals as the PEs. The reason for this is that if **DBGEN** or **NIDEN** are LOW in to the PE, self-hosted debug is disabled in the PE. Arm recommends that **DBGEN** and **NIDEN** to the MEM-AP are used to control access to the system and **DBGEN** and **NIDEN** to the PE are tied HIGH.

For Armv8-A, Armv8-R, or Armv9-A PEs, Arm recommends that the authentication interface to the MEM-AP is used to control whether a debugger can access the system, and that any authentication interface to the PE controls whether certain levels of debug of the PE are permitted. Arm recommends that the MEM-AP uses a different authentication interface to the PE, to allow a debugger to be independently permitted or blocked, and debug of the PEs to be independently permitted or blocked.

For a system that implements the Realm Management Extension, the **RTPIDEN** signal must have the same value across the entire system and **RLPIDEN** signal must have the same value across the entire system. For more details, see *Arm® Coresight™ Architecture Specification*.

Authentication interface of an APv2 MEM-AP

An ADIV6 APv2 MEM-AP implements one of the following authentication interfaces:

No authentication interface

In this configuration, the MEM-AP is always permitted to perform memory accesses.

Authentication using DBGEN and NIDEN

This authentication interface is used when the MEM-AP cannot distinguish between Secure and Non-secure transactions, for example on an APB3 interface.

When **(DBGEN | NIDEN)** is True, the MEM-AP is permitted to perform accesses and **CSW.DeviceEn** is 0b1.

Authentication using **DBGEN**, **NIDEN**, **SPIDEN**, and **SPNIDEN**

This authentication interface is used when the MEM-AP can perform Secure and Non-secure transactions.

The authentication rules are:

- When **(DBGEN | NIDEN)** is True, the MEM-AP is permitted to perform Non-secure accesses and **CSW.DeviceEn** is 0b1.
- When **((DBGEN | NIDEN) & (SPIDEN | SPNIDEN))** is True, the MEM-AP is permitted to perform Secure accesses, and **CSW.DeviceEn** and **CSW.SDeviceEn** are 0b1.

———— Note ————

For ADIV6 APv2, Secure access is permitted when **SPIDEN** is not asserted and **SPNIDEN** is asserted. In some systems, the APv2 definition might be a change from APv1, for which on a MEM-AP, only **SPIDEN** is used for authentication and Secure transactions are not permitted when **SPIDEN** is not asserted, but only when **((DBGEN | NIDEN) & SPIDEN)** is True.

Authentication using **DBGEN**, **NIDEN**, **SPIDEN**, **SPNIDEN**, **RLPIDEN**, and **RTPIDEN**

This authentication interface is used when the MEM-AP supports the Realm Management Extension and can perform Secure, Non-secure, Realm, and Root transactions.

The authentication rules are:

- When **(DBGEN | NIDEN)** is True, the MEM-AP is permitted to perform Non-secure accesses, and **CSW.DeviceEn** is 0b1.
- When **((DBGEN | NIDEN) & (SPIDEN | SPNIDEN))** is True, the MEM-AP is permitted to perform Secure accesses, and **CSW.DeviceEn** and **CSW.SDeviceEn** are 0b1.
- When **((DBGEN | NIDEN) & RLPIDEN)** is True, the MEM-AP is permitted to perform Realm accesses, and **CSW.RMEEN[0]** is 0b1.
- When **((DBGEN | NIDEN) & (SPIDEN | SPNIDEN) & RLPIDEN & RTPIDEN)** is True, the MEM-AP is permitted to perform Root accesses, and **CSW.RMEEN[1]** is 0b1.

———— Note ————

For ADIV6 APv2, Secure access is permitted when **SPIDEN** is not asserted and **SPNIDEN** is asserted. In some systems, the APv2 definition might be a change from APv1, for which on a MEM-AP, only **SPIDEN** is used for authentication and Secure transactions are not permitted when **SPIDEN** is not asserted, but only when **((DBGEN | NIDEN) & SPIDEN)** is True.

The **AUTHSTATUS** register reflects the permitted level of debug. For detailed information, see [AUTHSTATUS, Authentication Status Register on page C2-201](#).

Authentication interface of a legacy APv1 MEM-AP

Legacy MEM-AP implementations of the APv1 architecture that is used for ADIV5 or earlier implement one of the following authentication interfaces:

No authentication interface

In this configuration, the MEM-AP is always permitted to perform memory accesses.

Authentication using a **DEVICEEN** signal

This authentication interface uses a **DEVICEEN** signal to control whether the MEM-AP is permitted to perform memory accesses.

DEVICEEN is an input to the MEM-AP. It is normally tied HIGH, so that it is asserted even when the Debug Enable signal, **DBGEN**, is LOW, allowing the MEM-AP to be programmed even when debug is disabled.

The value of the **DEVICEEN** signal is indicated in the **CSW.DeviceEn** field.

When **CSW.DeviceEn** is **0b0**, no transactions can be issued to any address, and any access to the Data Read/Write Register or to any of the Banked Data Registers immediately causes the **CTRL/STAT.STICKYERR** bit to be set to **0b1**. The access does not cause a MEM-AP transaction.

If there is no **DEVICEEN** signal for a device, the **CSW.DeviceEn** field must Read-As-One.

Authentication using **DEVICEEN** and **SPIDEN** signals

This authentication interface uses **DEVICEEN** and **SPIDEN** signals to control whether the MEM-AP is permitted to perform any memory accesses, or only Non-secure accesses.

The value of the **DEVICEEN** signal is indicated in the **CSW.DeviceEn** field, and the value of the **SPIDEN** signal is indicated in the **CSW.SPIDEN** field.

C2.2.2 Auto-incrementing the Transfer Address Register (TAR)

As indicated in *The MEM-AP registers on page C2-173*, the **TAR** holds an address in the address map of the debug resource that is connected to the MEM-AP. This address is used as:

- The address in the debug component memory map of read or write accesses that are initiated by a read or write of the **DRW**.
- The base address determines the address in the debug component memory map of read or write accesses that are initiated by a read or write of one of the Banked Data Registers or Data Access Registers, as described in *Accesses that initiate a memory access on page C2-175*.

Software can configure the MEM-AP to auto-increment the **TAR** on every read or write access to the **DRW**. Auto-incrementing is controlled by the **CSW.AddrInc** field.

When auto address incrementing is enabled, the address in the **TAR** is updated whenever an access to the **DRW** is successful. However, if the **DRW** transaction completes with an error response, or the transaction is aborted, the **TAR** is not incremented.

———— **Note** —————

Accesses to the Banked Data Registers and Data Access Registers never cause the **TAR** to auto-increment. The **AddrInc** field has no effect on accesses to the Banked Data Registers or Data Access Registers.

The permitted values of the **AddrInc** field are summarized in [Table C2-1](#).

Table C2-1 Summary of **AddrInc field values**

AddrInc value	Description	Support required?
0b00	Auto-increment off	Always.
0b01	Increment single	Always.
0b10	Increment packed	If Packed transfers are supported. See <i>Packed transfers on page C2-187</i> . If Packed transfers are not supported, the value 0b10 selects the Auto-increment off mode and reading the AddrInc value returns 0b00 .
0b11	Reserved	-

The modes of operation that is associated with each of the possible settings of this field are:

Auto-increment off

The address in the **TAR** is not automatically incremented, and remains unchanged after any Data Read/Write Register access.

Increment single

After a successful **DRW** access, the address in the **TAR** is incremented by the size of the access. For information about different access sizes, see *Variable access size for memory accesses on page C2-185*.

Note

It is IMPLEMENTATION DEFINED whether a MEM-AP supports transfer sizes other than word. If a MEM-AP only supports word transfers and Increment single is selected, the **TAR** always increments by four after a successful **DRW** transaction.

Increment packed

Setting **AddrInc** to **0b10**, Increment packed, enables packed transfers, which pack multiple halfword or byte memory accesses into a single word AP access. Packed transfers are described in more detail in *Packed transfers on page C2-187*.

It is IMPLEMENTATION DEFINED whether a MEM-AP supports packed transfers, but:

- An implementation that supports transfers smaller than a word must support packed transfers.
- Packed transfers cannot be supported on a MEM-AP that only supports word transfers.

When packed transfer operation is enabled and the transfer size is smaller than a word, each **DRW** access causes multiple memory accesses, and the value in the **TAR** is auto-incremented correctly after each memory access. For example:

- For packed accesses with a **CSW.Size** value of **0b001**, denoting halfword (16-bits) transfers, each **DRW** read access generates two data bus transfers. The value in the **TAR** is incremented by **0x2** after each successful data bus transfer. As described in *Packed transfers on page C2-187*, the two halfword values from the two reads are packed into a single 32-bit word that is returned through the APACC.
- With packed accesses enabled and a **CSW.Size** value of **0b000**, which denotes byte transfers, a single **DRW** write operation generates four 8-bit data bus transfers, and the **TAR** is incremented by **0x1** after each of these transfers.

Automatic address increment is only guaranteed to operate on the 10 least significant bits of the address that is held in the **TAR**. Whether it is possible to auto increment bit [10] and beyond is IMPLEMENTATION DEFINED, which means that auto address incrementing at a 1KB boundary is IMPLEMENTATION DEFINED. The size of the **TAR** incrementer can be obtained from the **CFG.TARINC** field.

For example, if the **TAR** is **0x14A4**, and the access size is word, successive accesses to the **DRW** increment **TAR** to **0x14A8**, **0x14AC**, and in steps of 4 bytes up to the end of the range:

- If **CFG.TARINC** is **0x0**, the incrementer size is not specified, and the debugger must not assume that the **TAR** wraps back to the beginning of each 1KB segment, or continues past the end of a 1KB segment. The end of the range is at **0x17FC**.
- If **CFG.TARINC** is **0x1**, the incrementer size is 10 bits, and the **TAR** wraps back to the beginning of each 1KB segment. The end of the range is at **0x17FC**.
- If **CFG.TARINC** is greater than **0x1**, the incrementer size is **9+TARINC** bits, and the **TAR** is increased until the end of the segment that is addressable with **9+TARINC** bits is reached, after which the **TAR** wraps back to the beginning of the segment. For example, if **CFG.TARINC** has the value **0x3**, the incrementer size is 12 bits, and the end of the range is at **0x1FFC**.

C2.2.3 Stalling accesses

An access to the **DRW** register, one of the Banked Data Registers, **BD0-BD3**, or one of the Direct Access Registers, **DAR0-DAR255**, might not complete until the memory access that is required to fetch the data from memory is completed. Therefore, to be able to support slow connections, a MEM-AP must support stalling accesses. Stalling accesses do not have to be completed within a fixed number of cycles.

An example of the importance of stalling accesses can be found in the Armv7 Debug Architecture, which specifies a mode of operation where accesses to the *Data Transfer Registers* (DTRs) and *Instruction Transfer Register* (ITR) do not complete until the PE is ready to accept new data. The following sequence describes how a PE that complies with the Armv7 Debug Architecture, and an ADIV6 implementation that comprises a MEM-AP and a JTAG-DP, might co-operate to inform the debugger that it has to retry an access because of such a condition.

1. The initial conditions are:
 - The PE is idle and configured to stall accesses to its ITR and DTRs when it is not ready to accept new data.
 - The DP **SELECT-SELECT1** register addresses a MEM-AP with a connection to the PE.
 - The AP **TAR** addresses the ITR of the PE.
2. The debugger writes a first instruction to the ITR:
 - a. The debugger performs an AP write to **DRW** with the first instruction to execute:
 - The AP is ready, so the DP returns an OK ACK response.
 - In the Update-DR state, the DP initiates a transfer to the AP.
 - b. The **TAR** addresses the ITR on the PE, and the AP access consists of a write to the **DRW**. Therefore, the AP initiates a write to the ITR through its connection to the PE.
 - c. The core accepts the transfer, because the PE is idle and the instruction complete flag, **InstrCompl**, is **0b1**.
 - d. The transfer completes.
 - e. The core starts to execute the instruction from the ITR. **InstrCompl** is set to **0b0**.

———— **Note** —————

The ACK value OK is issued before the transfer is accepted by the PE.

3. The debugger writes a second instruction to the ITR:
 - a. The debugger performs an AP write to **DRW** with the next instruction to execute:
 - The AP is ready, so the DP returns an OK ACK response.
 - In the Update-DR state, the DP initiates a transfer to the AP.
 - b. The **TAR** has not changed, and the AP initiates a second write to the ITR through its connection to the PE.
 - c. The core is still executing the first instruction (**InstrCompl** is **0b0**) and cannot accept the transfer.
 - d. The transfer cannot complete, and the AP remains busy.

———— **Note** —————

ACK returns the value OK because the AP is ready to accept a new transfer. The AP does not know that the PE is not able to accept the transfer until it attempts the transfer.

4. The debugger writes a third instruction to the ITR:
 - a. The debugger performs an AP write to **DRW** with the next instruction to execute:
 - The AP is not ready, so the DP returns a WAIT ACK response.
 - In the Update-DR state, the DP discards the AP access request, because the AP was not ready at Capture-DR.
 - b. The debugger might retry the AP write until the DP returns the ACK value OK instead of WAIT in the Capture-DR state to signal that the first instruction has completed.

5. When the PE completes the first instruction, the following happens:
 - a. InstrCompl is set to 0b1.
 - b. The external debug interface on the PE is now ready to accept the second instruction.
 - c. The AP transfer from stage 3 is accepted by the PE, and the second instruction is written to the ITR.
 - d. The PE starts to execute the second instruction. InstrCompl is set to 0b0 again.
 - e. Because the AP transfer is complete, the AP returns to the ready state.
6. The debugger retries writing the third instruction to the ITR:
 - a. The debugger performs an AP write to DRW with the third instruction:
 - The AP is ready, so the DP returns an OK ACK response.
 - In the Update-DR state, the DP initiates a transfer to the AP.
 - b. The TAR has not changed, therefore, the AP initiates another write to the ITR through its connection to the PE.
 - c. The response to the AP write attempt depends on whether the PE has finished processing the last instruction that was written to the ITR:
 - If the PE is idle (InstrCompl is 0b1), the AP transfer completes, writing a new instruction to the ITR. The PE starts to execute the new instruction, and the AP returns to the ready state. This stage, stage 6, of the debug session is repeated for the next instruction from the debugger.
 - If the PE is still processing the previous instruction, InstrCompl is 0b0. The PE cannot accept the transfer and the AP remains busy. The debug session repeats stage 4.

C2.2.4 Error Handling

The *Transfer Response Register (TRR)* logs any errors that occurred during MEM-AP memory accesses. For details, see the TRR field descriptions.

The CSW register provides the following fields to control handling of MEM-AP memory access error responses:

- CSW.ERRNPASS, to control whether the MEM-AP passes an error response upstream to the requester.
- CSW.ERRSTOP, to control whether the MEM-AP prevents memory accesses that are attempted after it receives an error response.

The `CSW.ERRNPASS` and `CSW.ERRSTOP` fields are both 1-bit fields, allowing four possible combinations. Each combination corresponds to one of the following usage modes:

Table C2-2

Value of <code>CSW.ERRNPASS</code>	Value of <code>CSW.ERRSTOP</code>	Functionality
0b0	0b0	<p>Errors are passed back to the Requester, which handles the error immediately.</p> <p>This mode is used in the following situations:</p> <ul style="list-style-type: none"> The Requester can handle error responses precisely, provided the debug link supports immediate return of error responses. <p>This usage is common over a JTAG or SWD link.</p> <ul style="list-style-type: none"> High-latency debug links that favor issuing multiple transactions before the result of the first transaction is known, and for which an error response is not a critical failure so that transactions can proceed despite an error response. <p>This usage is useful over links with high latency, for example USB links. An example is using it for bulk reads and writes of normal memory for which future transactions are not critical.</p>
0b0	0b1	<p>This mode is used for high-latency debug links that favor issuing multiple transactions before the result of the first transaction is known, and for which an error response is a critical failure.</p> <p>This usage is useful over links with high latency, for example USB links. An example is using it to prevent incorrect programming of control registers when previous programming has failed.</p>
0b1	0b0	<p>This mode is used when the debug link does not support precise handling of error responses, for example when the debug agent is running on an on-chip PE that does not support precise asynchronous aborts, but where reading or writing blocks of memory means that future transactions can proceed regardless of the error response.</p> <p>This usage is useful over links that do not support error responses on writes, such as PCIe posted writes.</p>
0b1	0b1	<p>This mode is used when the debug link does not support precise handling of error responses, for example when the debug agent is running on an on-chip PE that does not support precise asynchronous aborts, and where the occurrence of an unexpected error response means that more transactions must not be attempted, for example when programming control registers.</p> <p>This usage is useful over links that do not support error responses on writes, such as PCIe posted writes.</p>

The behavior of the MEM-AP depends on whether the access initiates a memory access. Accesses that initiate a memory access are reads or writes to one of the following:

- The `DRW`.
- The Banked Data registers (`BD0-BD3`).

- The Direct Access Registers ([DAR0-DAR255](#)).
- The Memory Barrier Transfer register ([MBT](#)).

Behavior for accesses that initiate a memory access

For all accesses that initiate a memory access:

1. If [CSW.TrInProg](#) is 0b1, behavior of the MEM-AP is UNPREDICTABLE, and Arm recommends that the MEM-AP always returns an error response to the Requester.
2. Otherwise, if the authentication interface on the MEM-AP prevents a transaction:
 - No access is performed on the output of the MEM-AP.
 - If the [TRR](#) is implemented, an error is logged in [TRR.ERR](#).
 - If [CSW.ERRNPASS](#) is 0b0, an error is passed back to the Requester.
3. Otherwise, if [TRR.ERR](#) is 0b1 and [CSW.ERRSTOP](#) is 0b1:
 - No access is performed on the output of the MEM-AP.
 - [TRR.ERR](#) remains at 0b1.
 - If [CSW.ERRNPASS](#) is 0b0, an error is passed back to the Requester.
4. Otherwise, if the memory access is performed on the output of the MEM-AP, and an error response is received from the memory system:
 - If the [TRR](#) is implemented, an error is logged in [TRR.ERR](#).
 - If [CSW.ERRNPASS](#) is 0b0, an error is passed back to the Requester.
5. Otherwise, if the memory access is performed on the output of the MEM-AP, and an abort request is received by the MEM-AP:
 - If the [TRR](#) is implemented, an error is logged in [TRR.ERR](#).
 - An error is passed back to the Requester, regardless of the value of [CSW.ERRNPASS](#).
6. Otherwise, the memory access is successful:
 - [TRR.ERR](#) is unchanged.
 - No error is passed back to the Requester.

Behavior for accesses that do not initiate a memory access:

For all accesses that do not initiate a memory access:

1. If [CSW.TrInProg](#) is 0b1, behavior of the MEM-AP is UNPREDICTABLE, and Arm recommends:
 - That the MEM-AP permits reads to the registers so a debugger can try to determine the cause of the problem.
 - That writes to MEM-AP registers return an error response to the Requester, regardless of the value of [CSW.ERRNPASS](#).
2. Otherwise, the access is successful:
 - [TRR.ERR](#) is unchanged.
 - No error is passed back to the Requester, regardless of [CSW.ERRNPASS](#).

C2.2.5 Response to debug component errors

If the MEM-AP receives an error response from a debug component, and the error handling flag [CSW.ERRNPASS](#) is configured to pass errors upstream, it returns an error to the DP. As a result of this error, the DP sets the [CTRL/STAT.STICKYERR](#) flag.

For more information about AP error responses, see [Error Handling on page C2-182](#).

For more information about error handling flags, see [Sticky flags and DP error responses on page B1-43](#).

C2.2.6 Variable access size for memory accesses

It is IMPLEMENTATION DEFINED whether a MEM-AP supports memory access sizes other than word (32-bit).

If a MEM-AP implementation does not support the Large Data Extension, but does support various access sizes, it *must* support word, halfword, and byte accesses.

———— Note ————

The ADI specification does not require a MEM-AP to support access sizes other than word. However, if a MEM-AP can access other memory, such as system memory, Arm recommends that it supports other access sizes as well. For more information, see [MEM-AP implementation requirements on page C2-193](#).

The access size is controlled by the `CSW.Size` field. [Table C2-3](#) shows the access size options.

Table C2-3 Size field values when the MEM-AP supports different access sizes

Size value, <code>CSW.Size</code>	Memory access size	Support required?
0b000	Byte (8-bits)	No
0b001	Halfword (16-bits)	No
0b010	Word (32-bits)	Yes ^a
0b011 ^b	Doubleword (64-bits)	No
0b100 ^b	128-bits	No
0b101 ^b	256-bits	No
0b110 - 0b111	Reserved	-

- a. On a MEM-AP implementation that does not support access sizes other than word, the Size field is read-only, and always returns the value 0b010.
- b. Supported by the MEM-AP Large Data Extension, see [MEM-AP Large Data Extension on page C2-193](#). If the extension is not implemented, this value is reserved.

When a `CSW.Size` specifies a size that is smaller than a word, the resulting data access is returned in byte lanes. See [Byte lanes on page C2-186](#) for more information.

———— Caution ————

If a Banked Data Register is accessed with `CSW.Size` set to any size other than word or doubleword, behavior is UNPREDICTABLE.

C2.2.7 Byte lanes

A MEM-AP that supports memory transfers of less than 32-bits uses byte lanes for the data transfers between the DRW and the debug component. Which byte lanes are used depends on:

- The memory transfer size that is specified by the CSW.Size field, see *Variable access size for memory accesses* on page C2-185.
- The two least significant bits of the TAR, TAR[1:0].

If supported, packed transfers also use byte lanes for byte and halfword transfers, as described in *Packed transfers* on page C2-187.

Table C2-4 shows how byte lanes are used in the DRW.

Table C2-4 Byte-laning of memory accesses from the DRW

CSW[2:0], Size	TAR[1:0]	Access data
0b000, byte	0b00	DRW[7:0]
	0b01	DRW[15:8]
	0b10	DRW[23:16]
	0b11	DRW[31:24]
0b001, halfword	0b00	DRW[15:0]
	0b10	DRW[31:16]
	0bX1	IMPLEMENTATION DEFINED ^a
0b010, word	0b00	DRW[31:0]
	0b1X, 0bX1	IMPLEMENTATION DEFINED ^a

a. IMPLEMENTATION DEFINED behavior is one of the following:

Unaligned portions of the address are ignored. For example, an unaligned word access to 0x8003 accesses the 32-bit value at 0x8000.

The access is faulted, and the MEM-AP returns an error response.

The access is made to the unaligned address specified in TAR[31:0], and the result is packed as if packed transfers were enabled, see *Packed transfers* on page C2-187. The data transfer might be split into more than one memory access across the connection to the debug component.

For example, an unaligned word access to 0x8003 accesses the bytes at 0x8003, 0x8004, 0x8005, and 0x8006. This word access might generate four byte-wide accesses to memory, or the accesses to bytes 0x8004 and 0x8005 might be performed as a single halfword (16-bit) access.

Big-endian support

The byte lane with the lowest address corresponds to the least significant byte of DRW or BD0-BD3, and can be described as little-endian.

Previous versions of this manual described a variant of the MEM-AP that supported an alternative byte-lane scheme, where the byte lane with the lowest address corresponded to the most significant byte of DRW or BD0-BD3, or big-endian. Bit[0] of the CFG register was used to describe whether the MEM-AP was little-endian or big-endian. From ADIV5.2 onwards, this scheme is obsolete.

If the target uses a big-endian memory arrangement, the external debugger must treat the values that are passed through the MEM-AP accordingly.

C2.2.8 Packed transfers

Whether a MEM-AP supports packed transfers is IMPLEMENTATION DEFINED. If packed transfers are supported, they are enabled by setting the auto address increment field, `CSW.AddrInc`, to `0b10` (Increment packed). See [Auto-incrementing the Transfer Address Register \(TAR\)](#) on page C2-179.

When packed transfers are enabled, each access to the `DRW` results in one of the following actions, depending on the value of the `CSW.Size` field, see [Variable access size for memory accesses](#) on page C2-185:

- If `CSW.Size = 0b010` (word), there is a single word (32-bit) access.
- If `CSW.Size = 0b001` (halfword), there are two halfword (16-bit) accesses.
- If `CSW.Size = 0b000` (byte), there are four byte (8-bit) accesses.

Use of packed transfers with `CSW.Size` set to a transfer size larger than word is UNPREDICTABLE.

When packed transfers are enabled, after each successful memory access the address held in the `TRR` is automatically updated by the access size.

Accesses are always made in increasing memory address order:

- For write accesses to memory, data is unpacked from the `DRW` in byte-lanes that depend on the memory address of each write access.
- For read accesses, data is packed into the `DRW` in byte-lanes that depend on the memory address of each read access.

The byte lanes for data packing and unpacking are the same as the byte lanes that are described in [Table C2-4](#) on page C2-186, as shown in the following examples:

- [Example C2-1, Halfword packed write operation.](#)
- [Example C2-2 on page C2-188, Byte packed write operation on page C2-188.](#)
- [Example C2-3 on page C2-188, Halfword packed read operation on page C2-188.](#)

———— Note —————

The descriptions in these examples assume that each memory access completes successfully. If any access terminates with an error response, the sequence is halted at that point, and the MEM-AP returns an error.

Example C2-1 Halfword packed write operation

This example describes a single word (32-bit) write access to the `DRW` on a MEM-AP with the following settings:

- `CSW.Size = 0b001`, specifying halfword (16-bit) memory accesses.
- `CSW.AddrInc = 0b10`, specifying packed transfer operation.
- `TAR[31:0] = 0x00000000`, the base address of the access.

Two write transfers are made. The *halfword* entries in [Table C2-4](#) on page C2-186 define the byte lanes for these accesses. The accesses are made in the following order:

1. `TAR[1] = 0b0`, so `DRW[15:0]` is written to address `0x00000000`.
After this transfer, the value in the `TAR` is increased by the transfer size of 2, and becomes `0x00000002`.
2. `TAR[1] = 0b1`, so `DRW[31:16]` is written to address `0x00000002`.
After this transfer, the value in the `TAR` is increased by the transfer size, 2, and becomes `0x00000004`.

Example C2-2 Byte packed write operation

This example describes a single word (32-bit) write access to the **DRW** on a MEM-AP with the following settings:

- **CSW.Size** = 0b000, specifying byte (8-bit) memory accesses
- **CSW.AddrInc** = 0b10, specifying packed transfer operation
- **TAR[31:0]** = 0x00000002, the base address of the access.

Four write transfers are made. The *byte* entries in [Table C2-4 on page C2-186](#) define the byte lanes for these accesses. The accesses are made in the following order:

1. **TAR[1:0]** = 0b10, so **DRW[23:16]** is written to address 0x00000002.
After this transfer, the value in the **TAR** is increased by the transfer size, 1, and becomes 0x00000003.
 2. **TAR[1:0]** = 0b11, so write **DRW[31:24]** is written to address 0x00000003.
After this transfer, the value in the **TAR** is increased by the transfer size, 1, and becomes 0x00000004.
 3. **TAR[1:0]** = 0b00, so write **DRW[7:0]** is written to address 0x00000004.
After this transfer, the value in the **TAR** is increased by the transfer size, 1, and becomes 0x00000005.
 4. **TAR[1:0]** = 0b01, so write **DRW[15:8]** is written to address 0x00000005.
After this transfer, the value in the **TAR** is increased by the transfer size, 1, and becomes 0x00000006.
-

Example C2-3 Halfword packed read operation

This example describes a single word (32-bit) read access to the **DRW** on a MEM-AP with the following settings:

- **CSW.Size** = 0b001, specifying halfword (16-bit) memory accesses.
- **CSW.AddrInc** = 0b10, to give packed transfer operation.
- **TAR[31:0]** = 0x00000002, to define the base address of the access.

Two read transfers are made. The little-endian halfword entries in [Table C2-4 on page C2-186](#) define the byte lanes for these accesses. The accesses are made in the following order:

- **TAR[1]** = 0b1, so read a halfword from address 0x00000002, and pack this value into **DRW[31:16]**.
After this transfer, the value in the **TAR** is increased by the transfer size, 2, and becomes 0x00000004.
 - **TAR[1]** = 0b0, so read a halfword from address 0x00000004, and pack this value into **DRW[15:0]**.
After this transfer, the value in the **TAR** is increased by the transfer size, 2, and becomes 0x00000006.
 - The complete word has been read into the **DRW**, and the APACC read access completes.
-

The optional DP transaction counter, described in [The transaction counter on page B1-45](#), enables an external debugger to make a single AP transaction request that generates multiple AP transactions. Each of these transactions transfers a single word (32-bits) of data, and the **TAR** is incremented automatically between the transactions. If the MEM-AP supports memory accesses smaller than word and packed transfers and packed transfer operation is enabled, each of the AP transactions that are driven by the transaction counter is split into multiple memory accesses. For example, if the transaction counter is programmed to generate eight word accesses, and the MEM-AP is programmed to make packed byte transfers, a total of 32 memory accesses of one byte are made.

C2.2.9 Completer Memory Ports

A MEM-AP can include a Completer memory port, which can be used by an external bus transaction Requester to access the area of memory that is requested by the MEM-AP. For example, the external bus transaction Requester can be permitted to access the debug registers of the system to which the MEM-AP is connected.

If a MEM-AP implements a Completer memory port, Completer memory port accesses are multiplexed with AP accesses. Completer memory port accesses have bit [31] of the access address forced to zero. A debug component can use the value of this address bit to distinguish between Completer memory port accesses and AP accesses.

For more information about MEM-AP memory addressing, see [BASE, Debug Base Address register on page C2-203](#).

C2.2.10 Twin MEM-APs

A twin MEM-AP solution enables an external debugger to use one logical MEM-AP, and on-chip software to use a separate logical MEM-AP. These MEM-APs can be physically in the same unit, and share IO ports and most of the programmers' model, while duplicating some physical registers between them.

All writable registers and status registers have unique copies in all MEM-APs, except for the following:

- [ITCTRL.IME](#) might be shared between all MEM-APs that share an input interface.
- [CSW.TrInProg](#) takes the same value for all MEM-APs that share an output memory interface.

———— Note ————

If the Large Data Extension is implemented, accesses to doublewords require two consecutive accesses to the [DRW, BD0-BD3](#), or [DAR0-DAR255](#) registers. Each logical MEM-AP must behave as a separate MEM-AP and tolerate interleaving of accesses to these registers in each independent MEM-AP.

One of each pair of logical MEM-APs is used by an external debugger and the other is used by on-chip software. No physical protection is provided to prevent access to both MEM-APs by a single agent. Each agent must only use one of the MEM-APs for a particular memory system.

If a memory system can be accessed through multiple MEM-APs, a debug agent must use only one of those APs. ROM Tables that are exposed to an external debugger must point to a single MEM-AP for each memory system, and the external debugger must use only that MEM-AP.

Other debug agents, for example on-chip software, must use the other APs and must not use the MEM-AP that is reserved for external debuggers.

The method for determining which APs can be used by on-chip debug agents is not defined in the architecture, but can be achieved through other methods, for example device descriptor tables.

If an abort request is issued to a pair of logical MEM-APs, all outstanding input transactions to the MEM-APs are aborted. Each logical MEM-AP that had an outstanding input transaction at the time of the abort request must follow the rules for handling abort requests, as defined in [MEM-AP response to an abort request through the DP ABORT register](#).

C2.2.11 Software access control

It is IMPLEMENTATION DEFINED whether the **CSW** register includes the debug software access enable flag **CSW.DbgSwEnable**.

Implementation of the Debug Software Access Enable function is deprecated.

If the Debug Software Access Enable function is not implemented:

- The system must treat **CSW.DbgSwEnable** as HIGH, and enable software access to the debug resources.
- **CSW.DbgSwEnable** is RES0.

When implemented, the **CSW.DbgSwEnable** flag can be applied as follows:

Using **DbgSwEnable** to control a Completer memory port

If a MEM-AP implements a Completer memory port, the **DbgSwEnable** flag can be used to enable or disable the port as shown in [Table C2-5](#). For information about Completer memory ports, see [Completer Memory Ports](#) on page C2-188.

Table C2-5 Using **DbgSwEnable to control a Completer memory port**

Value of DbgSwEnable	Effect on Completer memory port
0b0	Disabled.
0b1	Enabled. This value is the value after a reset.

Using **DbgSwEnable** to control software access to debug resources

The **DbgSwEnable** flag can drive a system-level signal, **DBGSWENABLE**. This signal gates software access to debug resources. For example, in a PE that complies with the Armv7 Debug Architecture, some CP14 registers are not accessible when **DBGSWENABLE** is LOW. For more information, see the *Arm Architecture Reference Manual, Armv7-A and Armv7-R edition*.

Table C2-6 Using **DbgSwEnable to control software access to debug resources**

Value of DbgSwEnable	Corresponding value of the DBGSWENABLE signal
0b0	LOW.
0b1	HIGH. This value is the value after a reset.

If **CSW.DbgSwEnable** is implemented and the MEM-AP is disabled, **CSW.DbgSwEnable** must be treated as one.

Caution

Arm strongly recommends not setting **CSW.DbgSwEnable** to zero. If **CSW.DbgSwEnable** is implemented, setting it to zero can cause software that is executing on the target to malfunction.

C2.2.12 Realm Management Extension

CFG.RME indicates whether the MEM-AP implements the Realm Management Extension.

When the Realm Management Extension is implemented, **CSW.RMEEN** is present and is used with both **CSW.SDeviceEn** and **CSW.DeviceEn** to indicate which memory accesses are permitted to be performed by the MEM-AP.

CSW.DeviceEn, **CSW.SDeviceEn**, and **CSW.RMEEN** indicate when memory accesses are permitted to each physical address (PA) space.

Table C2-8 and Table C2-7 describe the MEM-AP permitted memory accesses when Realm Management Extension is implemented or not implemented.

Table C2-7 MEM-AP permitted memory accesses, when Realm Management Extension is not implemented

CSW.DeviceEn	CSW.SDeviceEn	Permitted Memory Accesses
0b0	0bx	None
0b1	0b0	Non-secure only
0b1	0b1	Non-secure and Secure

Table C2-8 MEM-AP permitted memory accesses, when Realm Management Extension is implemented

CSW.DeviceEn	CSW.SDeviceEn	CSW.RMEEN	Permitted Memory Accesses
0b0	0bx	0bxx	None
0b1	0b0	0bx0	Non-secure only
0b1	0b0	0bx1	Non-secure and Realm
0b1	0b1	0bx0	Non-secure and Secure
0b1	0b1	0b01	Non-secure, Secure, and Realm
0b1	0b1	0b11	Non-secure, Secure, Realm, and Root

For a MEM-AP that can access system resources that do not have their own access controls for each PA space, the memory accesses initiated by the MEM-AP must be checked by a Granule Protection Check (GPC) process, such as that provided by a System MMU. Examples of system resources that do not have their own access controls for each PA space include:

- Normal system memory that supports multiple PA spaces.
- Memory that is dedicated to a single PA space and is not protected by a completer-side PA space filter that prevents an access with an incorrect PA space.
- A peripheral that processes data from one or more PA spaces but does not have any specific access controls to prevent accessing that data from an incorrect PA space. The external debug interfaces for a PE that implements FEAT_RME has these access controls and do not fall in this category.

In a typical system, this means that the memory accesses initiated by an AXI-AP must be checked by a GPC process.

In a typical system, this means that the memory accesses initiated by an APB-AP, where only debug peripherals are accessed, do not need to be checked by a GPC process. This is because debug peripherals that process data from one or more PA spaces typically have their own access controls. For example, a completer-side PA space filter that prevents non-Root accesses from accessing Root data.

In a system that implements the Realm Management Extension, a MEM-AP must be reset on an RME system reset.

C2.3 Implementing a MEM-AP

This section gives information about the implementation of a MEM-AP and contains the following:

- [IMPLEMENTATION DEFINED features of a MEM-AP implementation](#).
- [MEM-AP implementation requirements on page C2-193](#).
- [MEM-AP Extensions on page C2-193](#).

C2.3.1 IMPLEMENTATION DEFINED features of a MEM-AP implementation

The following features of a MEM-AP implementation are IMPLEMENTATION DEFINED:

- Whether the MEM-AP supports data bus access sizes other than word size.
- Whether the MEM-AP supports packed transfers.
- Whether the MEM-AP includes the [MEM-AP Large Physical Address Extension on page C2-193](#), which implements support for addresses larger than 32 bits.
- Whether the MEM-AP includes [MEM-AP Barrier Operation Extension on page C2-194](#), which implements support for barrier operations.
- Whether the MEM-AP supports the features that are described in [Software access control on page C2-190](#).

These implementation choices affect the following register fields:

- **CSW**.{DbgSwEnable, Mode, AddrInc, Size}.
- **CFG**.{LD, LA, BE}.

In addition, the **CSW** register can include the following optional fields, which are not described elsewhere in this chapter:

CSW.Prot and CSW.Type, bits[30:24] and bits[15:12]

These fields can be implemented to provide a bus access control mechanism. If implemented, it enables a debugger to specify flags for a memory access. The permitted values and their significance are IMPLEMENTATION DEFINED, because they relate to the underlying bus architecture. These bits must reset to a valid access type and Arm strongly recommends that these bits are reset to a useful access type. This reset value might not be zero. For example:

- If the bus supports privileged and non-privileged accesses, the reset value of this field must select privileged accesses.
- If the bus supports code and data accesses, the reset value must select data accesses.
- If the bus supports both Secure and Non-secure address spaces, **CSW.Prot** and **CSW.Type** must reset to select Non-secure addresses.

If these fields are set to a value which is not permitted for the bus access, and a bus access is requested, behavior of the MEM-AP is UNPREDICTABLE. The MEM-AP must not perform an invalid bus transaction, and Arm recommends the following behavior:

- No bus transaction is performed.
- If **CSW.ERRNPASS** is 0b0, an error response is generated.
- If implemented, **TRR.ERR** is set to 0b1.

CSW.SDeviceEn, bit[23]

This field can be implemented to indicate whether the MEM-AP can generate secure accesses.

Note

In ADIV5 and older versions of the architecture, the **CSW.SPIDEN** field is in the same bit position as **CSW.SDeviceEn**, and has the same meaning. From ADIV6, the name **SDeviceEn** is used to avoid confusion between this field and the **SPIDEN** signal on the authentication interface.

Several reference implementation options for implementers and users of MEM-APs when connecting to standard memory interfaces are defined in [Appendix E1 Standard Memory Access Port Definitions](#).

C2.3.2 MEM-AP implementation requirements

The descriptions that are given in the section [MEM-AP functions on page C2-177](#) indicate several areas where the MEM-AP functionality is IMPLEMENTATION DEFINED. However, the IMPLEMENTATION DEFINED features are inter-dependent. These dependencies are summarized here.

In a MEM-AP:

- The options for the size of data bus accesses are:
 - Support word (32-bit) accesses only.
 - Support word (32-bit), halfword (16-bit), and byte (8-bit) accesses, and optionally support larger access sizes.

No other combinations of supported access sizes are permitted. For more information, see [Variable access size for memory accesses on page C2-185](#).

- If access sizes smaller than word are not supported, packed transfers are not supported. Otherwise, it is IMPLEMENTATION DEFINED whether packed transfers are supported. For more information, see [Packed transfers on page C2-187](#).
- It is IMPLEMENTATION DEFINED whether access sizes larger than 32-bit are supported. If larger access sizes are not supported, *CFG.LD* is RAZ. For more information, see [MEM-AP Large Data Extension](#).
- It is IMPLEMENTATION DEFINED whether addresses larger than 32-bit are supported. If larger addresses are not supported, *CFG.LA* is RAZ. For more information, see [MEM-AP Large Physical Address Extension](#).
- It is IMPLEMENTATION DEFINED whether barrier operations are supported. If barrier operations are not supported, *CSW.Mode* is RAZ. For more information, see [MEM-AP Barrier Operation Extension on page C2-194](#).

C2.3.3 MEM-AP Extensions

The following subsections summarize the effects of the optional MEM-AP Extensions.

MEM-AP Large Physical Address Extension

The MEM-AP Large Physical Address Extension provides address spaces of up to 64-bits.

Implementing this extension changes the format of the following MEM-AP registers:

- [BASE, Debug Base Address register on page C2-203](#).
- [CFG, Configuration register on page C2-209](#).
- [CSW, Control/Status Word register on page C2-216](#).
- [DRW, Data Read/Write register on page C2-226](#).
- [TAR, Transfer Address Register on page C2-237](#).

MEM-AP Large Data Extension

The MEM-AP Large Data Extension can support 32-bit, 64-bit, 128-bit, or 256-bit accesses, in addition to optional 8-bit and 16-bit accesses.

The following registers have different formats to support this extension:

- [CSW, Control/Status Word register on page C2-216](#).
- [DRW, Data Read/Write register on page C2-226](#).
- [BD0-BD3, Banked Data registers on page C2-206](#).
- [DAR0-DAR255, Direct Access registers on page C2-219](#).
- [CFG, Configuration register on page C2-209](#).

Although the extension can support 64-bit, 128-bit, and 256-bit accesses, it does not require an implementation to support all these access sizes. If the **CSW.Size** field is written with a value corresponding to a size that is not supported, or with a reserved value:

- A read of the field returns a value corresponding to a supported size.
- MEM-AP behavior corresponds to the value returned by the read of the **CSW.Size** field.

If a MEM-AP implements the Large Data Extension and doubleword accesses or larger are to be performed, multiple consecutive accesses are required to the **DRW**, **BD0-BD3**, or **DAR0-DAR255** registers to perform a large data transaction. These consecutive accesses must be performed to the same register type, otherwise the behavior of the MEM-AP is UNPREDICTABLE. For detailed information about the rules for large data transactions on these registers, see their usage constraints in *MEM-AP register descriptions on page C2-201*.

MEM-AP Barrier Operation Extension

The MEM-AP Barrier Operation Extension provides support for barrier operations. If the bus supports a weak memory ordering model, then barrier operations must create order.

The following registers are new or have different formats to support this extension:

- *CSW, Control/Status Word register on page C2-216.*
- *MBT, Memory Barrier Transfer register on page C2-233.*

MEM-AP Memory Tagging Extension

The MEM-AP Memory Tagging Extension (MTE) provides support for accessing and updating Allocation tags:

- **CFG1** indicates support for the MTE.
- **T0TR** provides control over the MTE.
- **CSW.MTE** provides control over the MTE.

When memory tagging of accesses is disabled, system read accesses do not request the Allocation tag from the memory system.

When memory tagging of accesses is disabled, system write accesses do not update the Allocation tag.

When memory tagging of accesses is enabled, system read accesses request the Allocation tag from the memory system and store the tag received in **T0TR**, in the position defined by the following equations:

- $ADDR_LSB = CFG1.TAG0GRAN$
- $ADDR_MSB = CFG1.TAG0GRAN + (\log_2(32/CFG1.TAG0SIZE) - 1)$
- $ADDR_OFFSET = Address_accessed[ADDR_MSB:ADDR_LSB]$
- $T0TR_LSB = ADDR_OFFSET * CFG1.TAG0SIZE$
- $T0TR_MSB = (ADDR_OFFSET * CFG1.TAG0SIZE) + (CFG1.TAG0SIZE - 1)$
- $T0TR[T0TR_MSB:T0TR_LSB] = Allocation_tag$

Other bits of **T0TR** are unchanged.

When memory tagging of accesses is enabled, system write accesses update the Allocation tag in the memory system using data from **T0TR**, from the position defined by the following equations:

- $ADDR_LSB = CFG1.TAG0GRAN$
- $ADDR_MSB = CFG1.TAG0GRAN + (\log_2(32/CFG1.TAG0SIZE) - 1)$
- $ADDR_OFFSET = Address_accessed[ADDR_MSB:ADDR_LSB]$
- $T0TR_LSB = ADDR_OFFSET * CFG1.TAG0SIZE$
- $T0TR_MSB = (ADDR_OFFSET * CFG1.TAG0SIZE) + (CFG1.TAG0SIZE - 1)$
- $Allocation_tag = T0TR[T0TR_MSB:T0TR_LSB]$

MEM-AP Memory Encryption Contexts Extension

The MEM-AP Memory Encryption Contexts extension (MEC Extension) provides support for memory encryption contexts (MECs) to physical address (PA) spaces:

- `CFG.MECIDWIDTH` indicates the MECID width implemented by the MEM-AP.
- `MECID` defines the MECID output with memory accesses performed by the MEM-AP.

The MEM-AP ensures that an appropriate MECID is output for the selected PA space. For a PA space that supports MEC, any MECID value is appropriate. For a PA space that does not support MEC, a MECID of zero is the appropriate MECID value.

C2.4 MEM-AP examples of pushed-verify and pushed-compare

A DP might support pushed operations, as described in [Pushed-compare and pushed-verify operations on page B1-46](#). However, these operations involve interaction between the DP and an AP, because each pushed operation requires an AP read, which, in the case of a MEM-AP, requires a read from the connected debug memory system. This section gives some examples of pushed operations on a DP that is connected to a MEM-AP.

C2.4.1 Example of using a pushed-verify operation on a MEM-AP

The following pushed-verify mechanism verifies the contents of system memory:

1. Make sure that the MEM-AP [CSW](#) register is set up to increment the [TAR](#) after each access.
2. Write the start address of the memory region that is to be verified to the [TAR](#).
3. Write a series of expected values as AP transactions. On each write transaction, the DP issues an AP read access, compares the result against the value that is supplied in the AP write transaction, and sets the [CTRL/STAT.STICKYCMP](#) bit if the values do not match.

The [TAR](#) is incremented on each transaction.

In this way, the series of values that are supplied is compared against the contents of the memory region, and [STICKYCMP](#) is set to `0b1` if they do not match.

C2.4.2 Example of using a pushed-find operation on a MEM-AP

The following pushed-find mechanism searches system memory for a particular word:

1. Make sure that the MEM-AP [CSW](#) register is set up to increment the [TAR](#) after each access.
2. Write the start address of the debug register region that is to be searched to the [TAR](#).
3. Repeatedly write the value to be searched for as an AP write transaction to the [DRW](#). On each transaction, the MEM-AP reads the location indicated by the [TAR](#).

The return value is compared with the value supplied in the AP write transaction. If they match, the [STICKYCMP](#) flag is set to `0b1`. If they do not match, the [TAR](#) is incremented.

Pushed-find can be combined with byte lane masking to search for specific bytes.

For an example of how the transaction counter can refine this search operation, see [Example of using the transaction counter for a pushed-compare operation on a MEM-AP on page C2-197](#).

Pushed-find without address incrementing can be used to poll a single location, for example to test the value of a flag after completion of an operation.

C2.4.3 Example of using the transaction counter for a pushed-compare operation on a MEM-AP

The transaction counter can refine the pushed-compare search operation that is described in *Example of using a pushed-find operation on a MEM-AP* on page C2-196. Pushed-compare enables searching system memory for a particular word, or, when used with byte lane masking, specific bytes. The transaction counter enables using a single AP write transaction to search an area of memory.

To perform a search under the control of the transaction counter:

1. Make sure that the MEM-AP CSW register is set up to increment the TAR after each access.
2. Write the start address of the debug register region that is to be searched to the TAR.
3. Write to the transaction counter field, CTRL/STAT.TRNCNT to indicate the required number of repeat accesses. This value defines the size of the region to be searched.
4. Write the search value as an AP write to the DRW. The MEM-AP repeatedly reads the location indicated by the TAR. The value that is returned by each read is compared with the value supplied in the AP write transaction. If they match, the STICKYCMP flag is set to 0b1 and the operation completes.
 - The TAR is incremented.
 - If the transaction counter is non-zero, it is decremented.

The operation completes when either the STICKYCMP flag is set to 0b1 or after the final read when the transaction counter was zero.

C2.5 MEM-AP programmers' model

Table C2-9 shows a memory map of the MEM-AP registers, and indicates where they are described in detail.

Reserved addresses in the register memory map are RES0.

[Using the Debug Port to access Access Ports on page A1-28](#) explains how to access AP registers.

Table C2-9 MEM-AP APv2 programmers' model

Offset	Type	Name	Description
Direct Access Registers			
0x000 - 0x3FC	RW	DAR0-DAR255	See DAR0-DAR255, Direct Access registers on page C2-219 .
Reserved area			
0x400 - 0xCFC	-	-	Reserved, RES0.
Main control and status registers			
0xD00	RW	CSW	See CSW, Control/Status Word register on page C2-216 .
0xD04 - 0xD08	RW	TAR	See TAR, Transfer Address Register on page C2-237 . If the implementation includes the Large Physical Address Extension, the word at offset 0xD04 represents the least significant word of the transfer address, and the word at offset 0xD08 represents the most significant word. If the implementation does not include the Large Physical Address Extension, the word at offset 0xD04 represents the transfer address, and the word at offset 0xD08 is RES0.
0xD0C	RW	DRW	See DRW, Data Read/Write register on page C2-226 .
0xD10 - 0xD1C	RW	BD0-BD3	See BD0-BD3, Banked Data registers on page C2-206 .
0xD20	IMP DEF	MBT	See MBT, Memory Barrier Transfer register on page C2-233 . If the implementation does not include the Barrier Operation Extension, this register is RES0.
0xD24	RW	TRR	See TRR, Transfer Response register on page C2-241 .
0xD28 - 0xD2C	-	-	Reserved, RES0.
0xD30	RW	T0TR	See T0TR, Tag 0 Transfer register on page C2-239 .
0xD34 - 0xDD8	-	-	Reserved, RES0.
0xDDC	RW	MECID	See MECID, MECID value register on page C2-234 .
0xDE0	RO	CFG1	See CFG1, Configuration register 1 on page C2-212 .
0xDE4 - 0xDEC	-	-	Reserved, RES0.
0xDF0	RO	BASE	See BASE, Debug Base Address register on page C2-203 . If the implementation includes the Large Physical Address Extension, the word at this offset represents the most significant word of the debug base address. If the implementation does not include the Large Physical Address Extension, the word at this offset is RES0.
0xDF4	RO	CFG	See CFG, Configuration register on page C2-209 .

Table C2-9 MEM-AP APv2 programmers' model (continued)

Offset	Type	Name	Description
0xDF8	RO	BASE	See <i>BASE, Debug Base Address register</i> on page C2-203. If the implementation includes the Large Physical Address Extension, the word at this offset represents the least significant word of the debug base address. If the implementation does not include the Large Physical Address Extension, the word at this offset represents the entire debug base address.
0xDFC	RO	IDR	See <i>IDR, Identification Register</i> on page C2-228.
Reserved area			
0xE00 - 0xEFC	-	-	Reserved, RES0.
CoreSight management registers			
0xF00	RW	ITCTRL	See <i>ITCTRL, Integration Mode Control Register</i> on page C2-230.
0xF04 - 0xF9C	-	-	Reserved, RES0.
0xFA0	RW	<i>CLAIMSET</i> on page C2-214	See <i>CLAIMSET and CLAIMCLR, Claim Tag Set Register and Claim Tag Clear Register</i> on page C2-214.
0xFA4	RW	<i>CLAIMCLR</i> on page C2-214	
0xFA8	RO	<i>DEVAFF0</i> on page C2-221	See <i>DEVAFF0-DEVAFF1, Device Affinity Registers</i> on page C2-221.
0xFAC	RO	<i>DEVAFF1</i> on page C2-221	
0xFB0	WO	<i>LAR</i> on page C2-231	See <i>LAR and LSR, Lock Access Register and Lock Status Register</i> on page C2-231.
0xFB4	RO	<i>LSR</i> on page C2-231	
0xFB8	RO	AUTHSTATUS	See <i>AUTHSTATUS, Authentication Status Register</i> on page C2-201.
0xFBC	RO	DEVARCH	See <i>DEVARCH, Device Architecture Register</i> on page C2-222.
0xFC0	RO	<i>DEVID2</i> on page C2-224	See <i>DEVID1-DEVID2, Device Configuration Registers</i> on page C2-224.
0xFC4	RO	<i>DEVID1</i> on page C2-224	
0xFC8	RO	DEVID	See <i>DEVID, Device Configuration Register</i> on page C2-223.
0xFCC	RO	DEVTYPE	See <i>DEVTYPE, Device Type Register</i> on page C2-225.

Table C2-9 MEM-AP APv2 programmers' model (continued)

Offset	Type	Name	Description
0xFD0 - 0xFDC	RO	<i>PIDR4</i> on page C2-234- <i>PI DR7</i> on page C2-234	See <i>PIDR0-PIDR7, Peripheral Identification Register</i> on page C2-234.
0xFE0 - 0xFEC	RO	<i>PIDR0</i> on page C2-234- <i>PI DR3</i> on page C2-234	
0xFF0 - 0xFFC	RO	<i>CIDR0-CIDR3</i>	See <i>CIDR0-CIDR3, Component Identification Registers</i> on page C2-213.

C2.6 MEM-AP register descriptions

This section gives full descriptions of the MEM-AP registers.

The registers are listed alphabetically by name.

C2.6.1 AUTHSTATUS, Authentication Status Register

The **AUTHSTATUS** characteristics are:

Purpose

Reports the required security level and status of the authentication interface. Where functionality changes on a given security level, the change in status must be reported in this register.

The effect of each debug level being enabled or disabled is specific to each AP.

Usage constraints

AUTHSTATUS is accessible as follows:

Default

RO

Configurations

Included in all implementations.

Attributes

A 32-bit register.

Field Descriptions

The **AUTHSTATUS** bit assignments are:

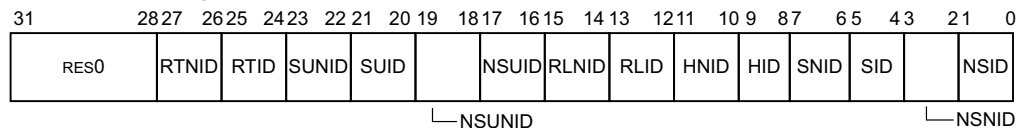

Bits[31:28]

RES0.

RTNID, bits[27:26]

Indicates the status of Root non-invasive debug.

If the MEM-AP does not implement the Realm Management Extension, this field has the value 0b00.

If the MEM-AP implements the Realm Management Extension and Root accesses are not permitted, this field has value 0b10.

If the MEM-AP implements the Realm Management Extension and Root accesses are permitted, this field has value 0b11.

RTID, bits[25:24]

Indicates the status of Root invasive debug.

If the MEM-AP does not implement the Realm Management Extension, this field has the value 0b00.

If the MEM-AP implements the Realm Management Extension and Root accesses are not permitted, this field has value 0b10.

If the MEM-AP implements the Realm Management Extension and Root accesses are permitted, this field has value 0b11.

SUNID, bits[23:22]

Secure Unprivileged non-invasive debug.
This field always takes the value 0b00.

SUID, bits[21:20]

Secure Unprivileged invasive debug.
This field always takes the value 0b00.

NSUNID, bits[19:18]

Non-secure Unprivileged non-invasive debug.
This field always takes the value 0b00.

NSUID, bits[17:16]

Non-secure Unprivileged invasive debug.
This field always takes the value 0b00.

RLNID, bits[15:14]

Realm non-invasive debug.
If the MEM-AP does not implement the Realm Management Extension, this field has value 0b00.
If the MEM-AP implements the Realm Management Extension and Realm accesses are not permitted, this field has value 0b10.
If the MEM-AP implements the Realm Management Extension and Realm accesses are permitted, this field has value 0b11.

RLID, bits[13:12]

Realm invasive debug.
If the MEM-AP does not implement the Realm Management Extension, this field has value 0b00.
If the MEM-AP implements the Realm Management Extension and Realm accesses are not permitted, this field has value 0b10.
If the MEM-AP implements the Realm Management Extension and Realm accesses are permitted, this field has value 0b11.

HNID, bits[11:10]

Hypervisor non-invasive debug.
This field always takes the value 0b00.

HID, bits[9:8]

Hypervisor invasive debug.
This field always takes the value 0b00.

SNID, bits[7:6]

Secure noninvasive debug. This field can have one of the following values:

- 0b00 Secure noninvasive debug is not implemented, or the status of Secure noninvasive debug is indicated elsewhere.
- 0b01 Reserved.
- 0b10 Secure noninvasive debug is not enabled.
- 0b11 Secure noninvasive debug is enabled.

When `CSW.SDeviceEn == 0b1`, this field has the value 0b11.

If the MEM-AP supports performing Secure accesses and `CSW.SDeviceEn == 0b0`, this field has the value 0b10.

If the MEM-AP does not support performing Secure accesses, this field has the value 0b00.

SID, bits[5:4]

Secure invasive debug. This field can have one of the following values:

- 0b00 Secure invasive debug is not implemented, or the status of Secure invasive debug is indicated elsewhere.
- 0b01 Reserved.
- 0b10 Secure invasive debug is not enabled.
- 0b11 Secure invasive debug is enabled.

When `CSW.SDeviceEn == 0b1`, this field has the value `0b11`.

If the MEM-AP supports performing Secure accesses and `CSW.SDeviceEn == 0b0`, this field has the value `0b10`.

If the MEM-AP does not support performing Secure accesses, this field has the value `0b00`.

NSNID, bits[3:2]

Non-secure non-invasive debug. This field can have one of the following values:

- 0b00 Non-secure non-invasive debug is not implemented, or the status of Non-secure noninvasive debug is indicated elsewhere.
- 0b01 Reserved.
- 0b10 Non-secure non-invasive debug is not enabled.
- 0b11 Non-secure non-invasive debug is enabled.

When `CSW.DeviceEn == 0b1`, this field has value `0b11`.

When `CSW.DeviceEn == 0b0`, this field has value `0b10`.

NSID, bits[1:0]

Non-secure invasive debug. This field can have one of the following values:

- 0b00 Non-secure invasive debug is not implemented, or the status of Non-secure invasive debug is indicated elsewhere.
- 0b01 Reserved.
- 0b10 Non-secure invasive debug is not enabled.
- 0b11 Non-secure invasive debug is enabled.

When `CSW.DeviceEn == 0b1`, this field has value `0b11`.

When `CSW.DeviceEn == 0b0`, this field has value `0b10`.

Accessing AUTHSTATUS

`AUTHSTATUS` can be accessed at the following address:

Offset

0xFB8

C2.6.2 BASE, Debug Base Address register

The `BASE` characteristics are:

Purpose

`BASE` provides an index into the connected memory-mapped resource. This index value points to one of the following:

- The start of a set of debug registers.
- A ROM Table that describes the connected debug components.

To discover information about the debug components that are connected to the MEM-AP, a debugger can examine the four Component ID registers, [CIDR0-CIDR3](#), which are at offset `0xFF0` from the base address. To examine `CIDR<n>`, the debugger writes its address, (base address + `0xFF0` + `n*4`), to the [TAR](#) and reads the [DRW](#) register. The return value allows the debugger to determine the component type of the connected component, which is one of the following:

- ROM Table
- Debug component
- Other

For more information about [CIDR0-CIDR3](#), see the *Arm® CoreSight™ Architecture Specification*.

Usage constraints

The following constraints apply:

- If the bus supports both Secure and Non-secure address spaces, [BASE](#) is defined to be a Non-secure address. Whether the ROM Tables are also accessible in the Secure address space is IMPLEMENTATION DEFINED.
- A debugger must handle the following situations as non-fatal errors:
 - The base address that is specified by `BASEADDR` is a faulting location.
 - The four words starting at (base address + `0xFF0`) are not valid Component ID registers.
 - An entry in the ROM Table points to a faulting location.
 - An entry in the ROM Table points to a memory block that does not have a set of four valid Component ID registers at offset `0xFF0`.

Typically, a debugger issues a warning if it encounters one of these situations. However, Arm recommends that it continues operating. An example of an implementation that might cause errors of this type is a system with static base address or ROM Table entries that enable entire subsystems to be disabled, for example by a tie-off input, packaging choice, fuse, or similar.

[BASE](#) is accessible as follows:

Default

RO

Configurations

In the 64-bit register implementation, the two words making up the register are not contiguous in the MEM-AP programmers' model.

Early implementations of the ADI had different implementations of [BASE](#), as described in *Legacy format of BASE on page C2-206*. The legacy format is a 32-bit register at offset `0xDF8`.

When [BASE](#) is implemented as a 64-bit register, it can specify any address in a 64-bit physical address space. However:

- Armv7-A PEs with the MMU disabled, and Armv7-R, Armv6-M, Armv7-M, and Armv8-M PEs can access only a 32-bit physical address space.

Therefore, Arm recommends that all debug components:

- Are located in the bottom 4GB of the physical address space.
- Are located in one 2GB half of the physical address space.

Attributes

A 32-bit or 64-bit read-only register.

Field Descriptions

The **BASE** bit assignments are:

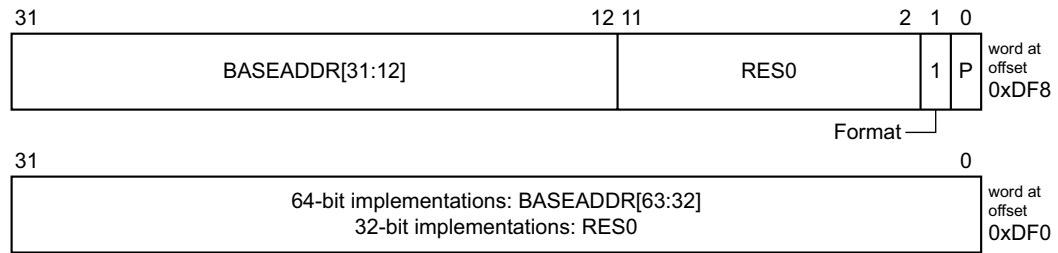

BASEADDR[63:32], bits[31:0] of word at offset 0xDF0, 64-bit register only

BASEADDR[31:12], bits[31:12] of word at offset 0xDF8

The 20 or 52 most significant bits of the base address, which is the address offset of the start of the debug register space in the memory-mapped resource, or a ROM Table address. BASEADDR is padded with the 12-bit value 0x000 to complete the 32-bit or 64-bit base address.

If **BASE** is implemented as a 32-bit register, the word at offset 0xDF0 is RES0.

The details of the memory area pointed to by the base address depend on the number of debug components that are connected to the ADI:

- If the ADI is connected to a single debug component, as in the system that is shown in [Figure A1-4 on page A1-32](#), the base address is the start of the debug registers for that component.
If a debug component occupies more than one 4KB page of memory, the base address is the address of the 4KB page that contains the Peripheral ID and Component ID registers of the component.
- If the ADI is connected to more than one debug component, as in the system that is shown in [Figure A1-7 on page A1-34](#), the base address is the address of a ROM Table, which contains the addresses of the other debug components that are connected to the interface. For information about ROM Tables, see [Chapter D1 About ROM Tables](#).
A system that contains only a single debug component might be implemented with a separate ROM Table, as shown in [Figure A1-6 on page A1-33](#). In this case, the base address is the address of the ROM Table.

Bits[11:2] of word at offset 0xDF8

Reserved, RES0.

Format, bit[1] of word at offset 0xDF8

Base address register format.

This field is RAO, indicating the ADIV6 format.

———— **Note** ————

This bit is RAZ in one of the legacy Debug Base Address register formats, see [Legacy format of BASE on page C2-206](#).

P, bit[0] of word at offset 0xDF8

This field indicates whether a debug entry for this MEM-AP is present:

- 0b0 No debug entry is present.
- 0b1 Debug entry is present.

———— **Note** ————

[Legacy format of BASE on page C2-206](#) includes a description of the legacy format of the **BASE** register when there is no debug entry present.

Accessing BASE

BASE can be accessed from the MEM-AP register space:

Offset if Large Physical Address extension is not implemented	Offset if Large Physical Address extension is implemented	
	Least significant word	Most significant word
0xDF8	0xDF8	0xDF0

Legacy format of BASE

The legacy format of **BASE** is as follows:

Legacy format when no debug entries are present

The legacy format of **BASE** when there are no debug entries present is:

NOTPRESENT, bits[31:0]

This field has the value 0xFFFFFFFF, indicating that there are no debug entries.

Legacy format for specifying BASEADDR

When bit[1] of the **BASE** register is 0b0, the legacy format of the register holds the base address value. This format is:

BASEADDR, bits[31:12]

Bits[31:12] of the base address. Bits[11:0] of the base address are zero.

Bits[11:2]

Reserved, RAZ.

FORMAT, bit[1]

RAZ, indicating that the **BASE** register uses the legacy 32-bit **BASE** register format.

Bit[0]

Reserved, RAZ.

The legacy format is defined only for 32-bit addresses and not permitted for a MEM-AP that implements the Large Physical Address Extension.

The legacy format must not be used for new ADI designs.

C2.6.3 BD0-BD3, Banked Data registers

The **BD0-BD3** register characteristics are:

Purpose

BD0-BD3 map AP accesses directly to memory accesses, without having to change the value in the **TAR**. Together, **BD0-BD3** give access to four words of the memory space, starting at the address that is specified in the **TAR**.

Each Banked Data register holds a 32-bit data value:

- In write mode, a Banked Data register holds a value to write to memory.
- In read mode, a Banked Data register holds a value that is read from memory.

Usage Constraints

Auto address incrementing is not performed when a Banked Data register is accessed. The value of **CSW.AddrInc** has no effect on Banked Data register accesses.

The Large Data Extension supports memory access size values that are greater than word size, as described in *Variable access size for memory accesses*.

- If the Large Data Extension is implemented, accesses other than word or doubleword are UNPREDICTABLE.

- If the Large Data Extension is not implemented, accesses other than word are UNPREDICTABLE.

BD0-BD3 are accessible as follows:

Default
RW

Configurations

Included in all implementations.

Attributes

Four 32-bit read/write registers.

Field Descriptions

The BD0-BD3 bit assignments are:



Banked data, BD0-BD3 bits[31:0]

Data values for the current transfer.

See [Accessing BD0-BD3](#) for more information about BD register accesses.

Accessing BD0-BD3

BD0-BD3 can be accessed from the MEM-AP register space.

If the Large Physical Address Extension is not implemented, BD0-BD3 can be accessed at the following offsets:

Register	Offset	Memory Address that is accessed	
		Word Access ^a	Doubleword Access ^b
BD0	0x10	TAR[31:4] << 4	TAR[31:4] << 4, accessed first
BD1	0x14	(TAR[31:4] << 4) + 0x4	TAR[31:4] << 4, accessed second
BD2	0x18	(TAR[31:4] << 4) + 0x8	(TAR[31:4] << 4) + 0x8, accessed first
BD3	0x1C	(TAR[31:4] << 4) + 0xC	(TAR[31:4] << 4) + 0x8, accessed second

If the Large Physical Address Extension is implemented, BD0-BD3 can be accessed at the following offsets:

Register	Offset	Memory Address that is accessed	
		Word Access ^a	Doubleword Access ^b
BD0	0x10	TAR[63:4] << 4	TAR[63:4] << 4, accessed first
BD1	0x14	(TAR[63:4] << 4) + 0x4	TAR[63:4] << 4, accessed second
BD2	0x18	(TAR[63:4] << 4) + 0x8	(TAR[63:4] << 4) + 0x8, accessed first
BD3	0x1C	(TAR[63:4] << 4) + 0xC	(TAR[63:4] << 4) + 0x8, accessed second

- a. Bits[1:0] of the address are always 0b00.
- b. Bits[2:0] of the address are always 0b000.

An access to a Banked Data register initiates an access to the memory address shown in the table. The AP access does not complete until the memory access has completed.

If the access size specified in CSW.Size is doubleword, the lower-numbered register holds the least significant word, and the higher-numbered register holds the most significant word. To access a value, a debugger must access both registers of the pair making up the doubleword, where the lower-numbered register is accessed first.

For example, if the Large Physical Address Extension is implemented, to read the doubleword value at (TAR[63:4] << 4), a debugger must:

1. Read BD0, to obtain bits[31:0] of the doubleword.
2. Read BD1, to obtain bits[63:32] of the doubleword.

When CSW.Size specifies doubleword access size, the following restrictions apply to the two required BD register accesses:

- The effect of mixing reads and writes in the sequence is UNPREDICTABLE.
- If CSW is accessed in the middle of the sequence, the following behavior is IMPLEMENTATION DEFINED:
 - Whether the CSW access is successful.
 - Whether the CSW access results in an error response from the AP.
- If CSW is accessed in the middle of the sequence, that sequence is terminated, and the next access to a Banked Data register is the first access of a new sequence.
 If a write sequence is terminated, no memory write is initiated.
- The effect of not accessing the appropriate register first is UNPREDICTABLE.
- After accessing the first Banked Data register of a pair, the effect of accessing any MEM-AP register other than CSW or the second Banked Data register of the pair is UNPREDICTABLE. Examples of sequences that lead to an UNPREDICTABLE result include:
 - Accessing BD1 and then accessing BD2.
 - Two consecutive accesses to the same Banked Data register.

C2.6.4 CFG, Configuration register

The [CFG](#) characteristics are:

Purpose

[CFG](#) indicates whether the MEM-AP implementation includes the Large Data and Large Physical Address Extensions.

Usage constraints

None.

[CFG](#) is accessible as follows:

Default

RO

Configurations

Included in all implementations.

Attributes

A 32-bit read-only register.

The [CFG](#) bit assignments are:

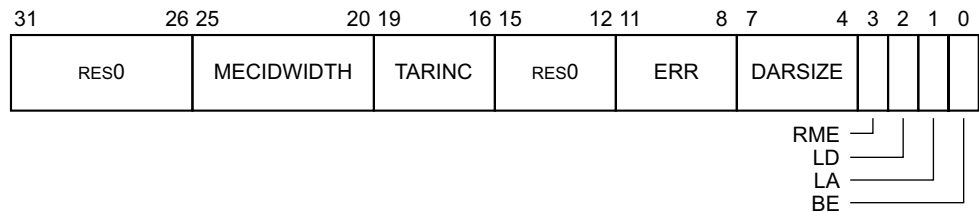

Bits[31:26]

Reserved, RES0.

MECIDWIDTH, bits[25:20]

MEC Extension. Indicates the size of the MECID in bits. The defined values of this field are:

0b000000 MEC extension is not implemented.

0b000001 .. 0b010000

MEC extension is implemented. The value indicates the [MECID](#) width, in bits.

See also [MEM-AP Memory Encryption Contexts Extension](#) on page C2-195.

TARINC, bits[19:16]

[TAR](#) incrementer size. This field has one of the following values:

0x0 The [TAR](#) incrementer size is not specified. If [TARINC](#) has this value, the [TAR](#) incrementer size is at least 10 bits.

Any other value

The [TAR](#) incrementer size is 9+[TARINC](#) bits. The maximum [TAR](#) incrementer size is 24 bits, indicated by [TARINC](#) having the value 0xF.

See also [Auto-incrementing the Transfer Address Register \(TAR\)](#) on page C2-179.

Bits[15:12]

Reserved, RES0.

ERR, bits[11:8]

Identifies the type of error handling that is implemented. This field has one of the following values:

- 0b0000 Error response handling 0:
- Error responses are always passed upstream.
 - [TRR](#) is not implemented.
 - [CSW.ERRNPASS](#) and [CSW.ERRSTOP](#) are not implemented.
- 0b0001 Error response handling 1:
- [TRR](#) is implemented.
 - [CSW.ERRNPASS](#) and [CSW.ERRSTOP](#) are implemented.

Any other value

Reserved.

See also [Error Handling on page C2-182](#).

DARSIZE, bits[7:4]

Indicates the size of the [DAR0-DAR255](#) register space. This field can have one of the following values:

- 0b0000 [DAR0-DAR255](#) are not implemented.
- 0b1010 [DAR0-DAR255](#), which occupy a register space of 1KB, are implemented

Any other value

Reserved.

See also [DAR0-DAR255, Direct Access registers on page C2-219](#).

RME, Bit[3]

Realm Management Extension. Indicates whether the MEM-AP includes the Realm Management Extension. The defined values of this bit are:

- 0b0 Realm Management Extension not implemented
- 0b1 Realm Management Extension implemented

LD, bit[2]

Large data. This bit indicates whether the MEM-AP implementation includes the Large Data Extension, which provides support for data items larger than 32-bits. LD has one of the following values:

- 0b0 The implementation does not support data items that are larger than 32 bits.
- 0b1 The implementation includes the Large Data Extension, and supports data items larger than 32 bits.

For more information, see [MEM-AP Large Data Extension on page C2-193](#).

Regardless of the value of the LD field, the MEM-AP must support word-size data items, and might support smaller data items. See also [CSW.Size](#).

LA, bit[1]

Long address. This field indicates whether the MEM-AP implementation includes the Large Physical Address Extension, which supports physical addresses of more than 32-bits. LA has one of the following values:

- 0b0 The implementation support only physical addresses of 32 bits or smaller. Memory locations for the [TAR](#) and [BASE](#) registers, which are at offsets 0xD08 and 0xDF0 in the MEM-AP register map, are reserved.
- 0b1 The implementation supports physical addresses with more than 32 bits:
- The [TAR](#) is a 64-bit register, at offsets 0xD04 and 0xD08 in the MEM-AP register map.
 - The [BASE](#) register is a 64-bit register, at offsets 0xDF8 and 0xDF0 in the MEM-AP register map.

For more information, see [MEM-AP Large Physical Address Extension on page C2-193](#).

BE, bit[0]

Big-endian. From ADIv5.2 onwards, support for big-endian MEM-APs is obsolete, and this bit must RAZ. For more information, see [Big-endian support on page C2-186](#).

Accessing CFG

CFG can be accessed from the MEM-AP register space:

Offset

0xDF4

C2.6.5 CFG1, Configuration register 1

The [CFG1](#) characteristics are:

Purpose

[CFG1](#) indicates the features of the implementation of the MEM-AP.

Usage constraints

[CFG1](#) is accessible as follows:

Default
RO

Configurations

Included in all implementations.

Attributes

A 32-bit read-only register.

Field descriptions

The [CFG1](#) bit assignments are:

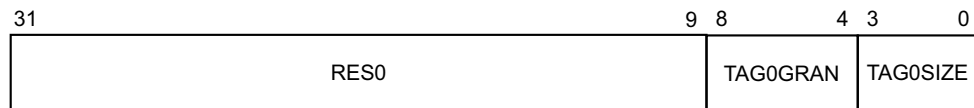

Bits[31:9]

Reserved, RES0.

TAG0GRAN, bits[8:4]

Memory tagging granule.

When Memory Tagging Extension implemented

0x04 Memory tagging granule is 16 bytes.
 All other values are reserved.

Otherwise

Reserved, RES0.

TAG0SIZE, bits[3:0]

Memory tagging support. The defined values of this field are:

0x0 Memory Tagging Extension not implemented. [T0TR](#) not implemented. [CSW.MTE](#) is not implemented.

0x4 Memory Tagging Extension implemented. Tag size is 4-bits. [T0TR](#) is implemented. [CSW.MTE](#) is implemented.

All other values are reserved.

Accessing CFG1

CFG1 can be accessed from the MEM-AP register space:

Offset

0xDE0

C2.6.6 CIDR0-CIDR3, Component Identification Registers

This section describes the bit assignments for MEM-AP components. For a full description of the CIDR registers, see *Arm® CoreSight™ Architecture Specification*.

The **CIDR0-CIDR3** characteristics are:

Purpose

Provide information to identify a CoreSight component.

Usage constraints

CIDR0-CIDR3 are accessible as follows:

Default

RO

Configurations

Included in all implementations.

Attributes

Four 32-bit management registers.

Field Descriptions

The **CIDR0-CIDR3** bit assignments are:

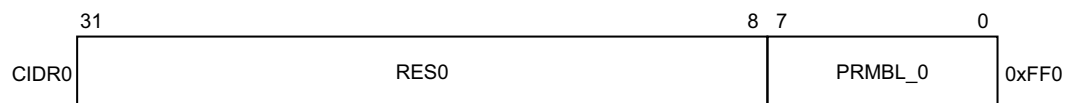
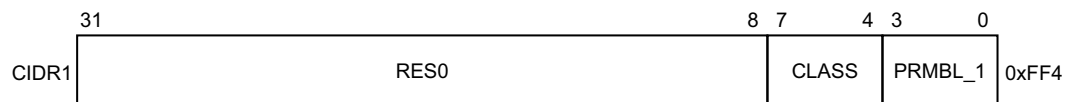
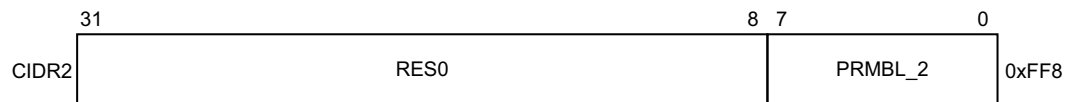
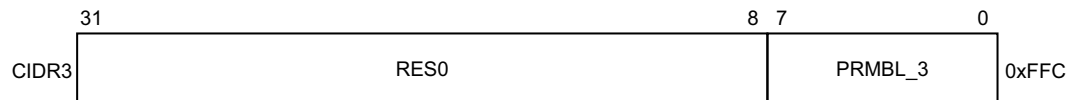

CIDR3 bits[31:8]

RES0.

PRMBL_3, CIDR3 bits[7:0]

0xB1.
CIDR2 bits[31:8]
 RES0.
PRMBL_2, CIDR2 bits[7:0]
 0x05.
CIDR1 bits[31:8]
 RES0.
CLASS, CIDR1 bits[7:4]
 0x9 CoreSight component.
PRMBL_1, CIDR1 bits[3:0]
 0x0.
CIDR0 bits[31:8]
 RES0.
PRMBL_0, CIDR0 bits[7:0]
 0x0D.

Accessing CIDR

[CIDR0-CIDR3](#) can be accessed at the following address:

Offset			
CIDR0	CIDR1	CIDR2	CIDR3
0xFF0	0xFF4	0xFF8	0xFFC

C2.6.7 CLAIMSET and CLAIMCLR, Claim Tag Set Register and Claim Tag Clear Register

The [CLAIMSET](#) and [CLAIMCLR](#) characteristics are:

Purpose

The claim tags are used to communicate between different debug agents and to claim usage of an APv2 AP. For detailed information, see [CLAIMSET and CLAIMCLR, Claim Tag Set Register and Claim Tag Clear Register](#) on page C1-156.

Usage constraints

[CLAIMSET](#) and [CLAIMCLR](#) are accessible as follows:

CLAIMSET	CLAIMCLR
RW	RW

Configurations

Included in all implementations.

Attributes

Two 32-bit registers.

Field Descriptions

The [CLAIMSET](#) and [CLAIMCLR](#) bit assignments are:

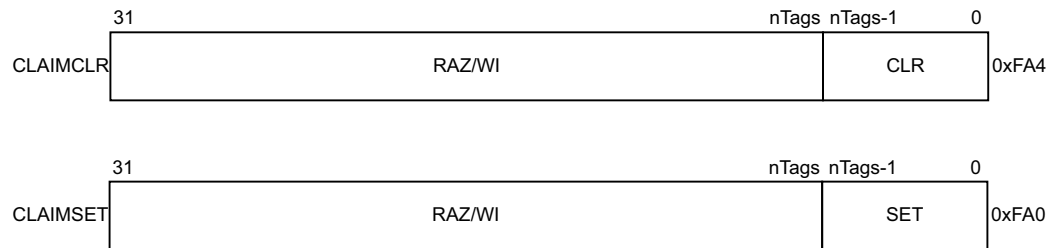

CLAIMCLR bits[31:nTags]

RAZ/WI

CLR, CLAIMCLR bits[nTags-1:0]

The size of this field, nTags, is IMPLEMENTATION DEFINED, and equals the number of bits set in CLAIMSET.

Allowed values of CLR[n] are:

- Write 0** No effect.
- Write 1** Clear the claim tag for bit[n].
- Read 0** The claim tag bit is not set.
- Read 1** The claim tag bit is set.

CLAIMSET bits[31:nTags]

RAZ/WI

SET, CLAIMSET bits[nTags-1:0]

The size of this field, nTags, is IMPLEMENTATION DEFINED, and equals the number of claim bits that are implemented.

Permitted values of SET[n] are:

- Write 0** No effect.
- Write 1** Set the claim tag for bit[n].
- Read 0** The claim tag that is represented by bit[n] is not implemented.
- Read 1** The claim tag that is represented by bit[n] is implemented.

Accessing CLAIMSET CLAIMCLR

[CLAIMSET](#) and [CLAIMCLR](#) can be accessed at the following addresses:

Offset	
CLAIMSET	CLAIMCLR
0xFA0	0xFA4

C2.6.8 CSW, Control/Status Word register

The CSW characteristics are:

Purpose

CSW configures and controls accesses through the MEM-AP to or from a connected memory system.

Usage constraints

None

CSW is accessible as follows:

Default

RW

Configurations

Included in all implementations.

Attributes

A 32-bit read/write register.

Field Descriptions

The CSW bit assignments are:

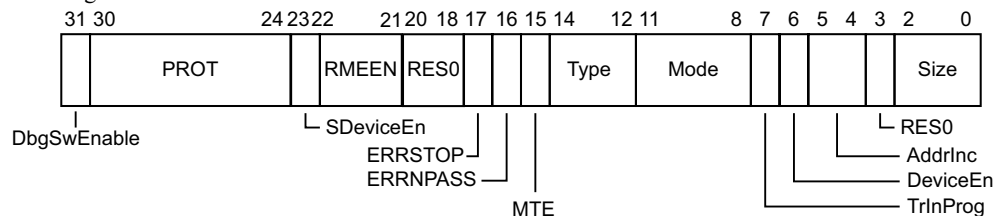

DbgSwEnable, bit[31]

Debug software access enable.

This field is optional. If not implemented, it is RAZ.

If implemented, it has one of the following values:

0b0 Debug software access is disabled. If DeviceEn is 0b0, DbgSwEnable must be ignored and treated as one.

0b1 Debug software access is enabled.

The use of this field is IMPLEMENTATION DEFINED, see [Software access control on page C2-190](#).

Prot, bits[30:24]

Used with the Type field to define the bus access protection control.

A debugger can use these fields to specify flags for a debug access. The permitted values and their significance are IMPLEMENTATION DEFINED, and depend on the underlying bus architecture. For more information, see [Implementing a MEM-AP on page C2-192](#).

These fields are OPTIONAL. If not implemented, they are RES0.

SDeviceEn, bit[23]

Secure Debug Enabled. This field has one of the following values:

0b0 Secure access is disabled.

0b1 Secure access is enabled.

This field is OPTIONAL, and read-only. If not implemented, the bit is RES0.

If `CSW.DeviceEn` is `0b0`, `SDeviceEn` is ignored and the effective value of `SDeviceEn` is `0b0`.

For more information, see [Enabling access to the connected debug device or memory system on page C2-177](#).

Note

In ADIV5 and older versions of the architecture, the `CSW.SPIDEN` field is in the same bit position as `CSW.SDeviceEn`, and has the same meaning. From ADIV6, the name `SDeviceEn` is used to avoid confusion between this field and the **SPIDEN** signal on the authentication interface.

RMEEN, Bits[22:21]

Realm and Root access status.

When `CFG.RME` == `0b1`

The defined values of this field are:

- | | |
|-------------------|---|
| <code>0b00</code> | Realm and Root accesses are disabled |
| <code>0b01</code> | Realm access is enabled. Root access is disabled. |
| <code>0b11</code> | Realm access is enabled. Root access is enabled. |

Otherwise

Reserved. This field is RES0.

All other values are reserved.

This field is read-only.

Bits[20:18]

Reserved, RES0.

ERRSTOP, bit[17]

Errors prevent future memory accesses. This field has one of the following values:

- | | |
|------------------|---|
| <code>0b0</code> | Memory access errors do not prevent future memory accesses. |
| <code>0b1</code> | Memory access errors prevent future memory accesses. |

The reset value of this field is UNKNOWN.

`CFG.ERR` indicates whether this field is implemented.

ERRNPASS, bit[16]

Errors are not passed upstream. This field has one of the following values:

- | | |
|------------------|---------------------------------|
| <code>0b0</code> | Errors are passed upstream. |
| <code>0b1</code> | Errors are not passed upstream. |

The reset value of this field is UNKNOWN.

`CFG.ERR` indicates whether this field is implemented.

Type, bits [15:12], when Memory tagging control is not implemented.

Used with the `Prot` field to define the bus access protection control.

A debugger can use these fields to specify flags for a debug access. The permitted values and their significance are IMPLEMENTATION DEFINED, and depend on the underlying bus architecture. For more information, see [Implementing a MEM-AP on page C2-192](#).

This field is OPTIONAL. If not implemented, it is RES0.

MTE, bit [15], when Memory tagging control is implemented.

Memory Tagging control. The possible values of this bit are:

- | | |
|------------------|-----------------------------------|
| <code>0b0</code> | Memory tagging accesses disabled. |
| <code>0b1</code> | Memory tagging accesses enabled. |

When memory tagging accesses are enabled, system read and write accesses via [DRW](#), [BD0-BD3](#), and [DAR0-DAR255](#), use [T0TR](#) for transferring tag information.

Type, bits [14:12], when Memory tagging control is implemented.

Used with the Prot field to define the bus access protection control.

A debugger can use these fields to specify flags for a debug access. The permitted values and their significance are IMPLEMENTATION DEFINED, and depend on the underlying bus architecture. For more information, see [Implementing a MEM-AP on page C2-192](#).

This field is OPTIONAL. If not implemented, it is RES0.

Mode, bits[11:8]

Mode of operation of the MEM-AP. This field has one of the following values:

0b0000 Basic mode.

0b0001 Barrier support enabled. For more information, see [MEM-AP Barrier Operation Extension on page C2-194](#).

Other Reserved.

The set of supported modes is IMPLEMENTATION DEFINED. If the implementation supports only one mode, this field can be RO.

If this field is RW, the reset value of this field is UNKNOWN.

TrInProg, bit[7]

Transfer in progress. This field has one of the following values:

0b0 The connection to the memory system is idle.

0b1 A transfer is in progress on the connection to the memory system.

After an ABORT operation, debug software can read this bit to check whether the aborted transaction completed.

DeviceEn, bit[6]

Device enabled.

This field has one of the following values:

0b0 The MEM-AP is not enabled.

0b1 Transactions can be issued through the MEM-AP.

See [Enabling access to the connected debug device or memory system on page C2-177](#).

This field is read-only.

AddrInc, bits[5:4]

Address auto-increment and packing mode. This field controls whether the access address increments automatically on read and write data accesses through the [DRW](#) register. For more information, see [Auto-incrementing the Transfer Address Register \(TAR\) on page C2-179](#) and [Packed transfers on page C2-187](#).

Address auto-increment and packing mode. The possible values are of this field are:

0b00 Address auto-increment disabled.

0b01 Address increment-single enabled.

0b10 Address increment-packed enabled.

All other values are reserved.

The reset value of this field is UNKNOWN.

Bit[3]

Reserved, RES0.

Size, bits[2:0]

The size of the data type that is used to access the MEM-AP, as shown in [Table C2-10](#) on [page C2-219](#).

It is IMPLEMENTATION DEFINED whether a MEM-AP supports access sizes other than 32-bits, and whether the Size field is RW or RO:

- If other sizes are supported, the Size field is RW, and the field indicates the size of the accesses to perform. When this field is RW, its reset value is UNKNOWN.
- If other sizes are not supported, this field is RO and it reads as 0b010 to indicate that only 32-bit accesses are supported.

Table C2-10 Size field values

Size Field	Data Type	Supported
0b000	Byte (8-bits)	IMPLEMENTATION DEFINED
0b001	Halfword (16-bits)	IMPLEMENTATION DEFINED
0b010	Word (32-bits)	Yes ^a
0b011 ^b	Doubleword (64-bits)	IMPLEMENTATION DEFINED
0b100 ^b	128-bits	IMPLEMENTATION DEFINED
0b101 ^b	256-bits	IMPLEMENTATION DEFINED
0b110 - 0b111	Reserved	-

- On a MEM-AP implementation that does not support access sizes other than word, the Size field is read-only, and always returns the value 0b010.
- Supported by the MEM-AP Large Data Extension, see [MEM-AP Large Data Extension](#) on [page C2-193](#). The following usage constraints apply:
If the extension is not implemented, this value is reserved.
If a reserved value, or a value corresponding to an unsupported access size, is written to this field, reading the field returns the value corresponding to a supported size, and the MEM-AP behaves according to the return value.

Accessing CSW

[CSW](#) can be accessed from the MEM-AP register space:

Offset

0xD00

C2.6.9 DAR0-DAR255, Direct Access registers

The [DAR0-DAR255](#) characteristics are:

Purpose

[DAR0-DAR255](#) map AP accesses directly to memory accesses, without having to change the value in the [TAR](#). Together, the 256 Direct Access Registers give access to 1KB of the memory space, which starts at the address that is specified in the [TAR](#).

Each DAR<n> holds a 32-bit data value:

- In write mode, a DAR<n> holds a value to write to memory.
- In read mode, a DAR<n> holds a value that is read from memory.

Usage Constraints

Auto address incrementing is not performed when a DAR<n> is accessed. The value of CSW.AddrInc has no effect on DAR accesses.

The Large Data Extension supports memory access size values that are greater than word size, as described in *Variable access size for memory accesses*. If the CSW.Size field is set to one of these memory access sizes, the following rules apply:

- A memory access involves accessing multiple DARs:
 - The number of DAR accesses is equal to the number of words in the memory access size.
 - The number n of the first DAR<n> to be accessed must be aligned to the number of words in the memory access size.

For the memory widths that are supported by the Large Data Extension, the rules work out as follows:

- Accessing two consecutive DARs returns a doubleword from memory address $((\text{TAR}[63:10] \ll 10) + (n \times 8))$, where the first access must be to DAR<n×2>, where n is between 0 and 127.
- Accessing four consecutive DARs returns a 128-bit word from memory address $((\text{TAR}[63:10] \ll 10) + (n \times 16))$, where the first access must be to DAR<n×4>, where n is between 0 and 63.
- Accessing eight consecutive DARs returns a 256-bit word from memory address $((\text{TAR}[63:10] \ll 10) + (n \times 32))$, where the first access must be to DAR<n×8>, where n is between 0 and 31.

For example, to read the doubleword value at $((\text{TAR}[63:10] \ll 10) + 32)$, a debugger must:

1. To obtain bits[31:0] of the doubleword, read DAR<4>.
 2. To obtain bits[63:32] of the doubleword, read DAR<5>.
- A debugger must access all registers of a sequence making up the targeted size, in the order of the DAR number.
 - The words that are returned by a sequence of DARs are increasingly significant as the DAR number increases.
 - The following restrictions apply to a sequence of DAR accesses:
 - The effect of mixing reads and writes in the sequence is UNPREDICTABLE.
 - If CSW is accessed in the middle of the sequence, that sequence is terminated, and the next access to a DAR<n> is the first access of a new sequence.
If a write sequence is terminated, no memory write is initiated.
 - The effect of not accessing the appropriate DAR<n> first is UNPREDICTABLE.
 - After accessing the first DAR<n> of a sequence, the effect of accessing any MEM-AP register other than CSW or the next DAR<n> in the sequence is UNPREDICTABLE.
- Examples of sequences that lead to an UNPREDICTABLE result include:
- Accessing a DAR<n> that forms the last word of a sequence first, and then accessing the first DAR<n> of the next sequence.
 - Two consecutive accesses to the same DAR<n>.

If the CSW.Size field is set to byte or halfword, accesses using DAR <n> are UNPREDICTABLE.

Accessing a sequence of DARs to access a memory width that is greater than word size has the following effects:

- When reading from memory, the first DAR<n> access in a sequence initiates a memory access.
- When writing to memory, the last DAR<n> access in a sequence initiates a memory access.
- The TAR is incremented after the last DAR<n> access in a sequence.
- The AP access does not complete until the associated memory access has completed.

DAR0-DAR255 are accessible as follows:

Default

RW

Configurations

Implemented when CFG.DARSIZE is not zero.

Attributes

A set of 256 32-bit read/write registers.

Field Descriptions

The DAR0-DAR255 bit assignments are shown in the following diagram, where <n> is between 0 and 255:

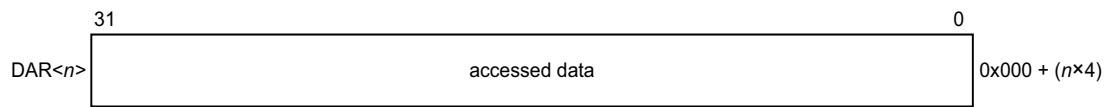

Directly accessed data, DAR0-DAR255 bits[31:0]

Data values for the current transfer, as subjected to the rules mentioned in the usage constraints.

Accessing DAR0-DAR255

DAR<n>, where $0 \leq n \leq 255$, can be accessed from the MEM-AP register space:

Offset

$0x000 + (n \times 4)$

C2.6.10 DEVAFF0-DEVAFF1, Device Affinity Registers

The DEVAFF0-DEVAFF1 characteristics are:

Purpose

Enables a debugger to determine whether two components have an affinity with each other.

Usage constraints

DEVAFF0-DEVAFF1 are accessible as follows:

Default

RO

Configurations

Included in all implementations.

Attributes

Two 32-bit registers.

Field Descriptions

The [DEVAFF0-DEVAFF1](#) bit assignments are:

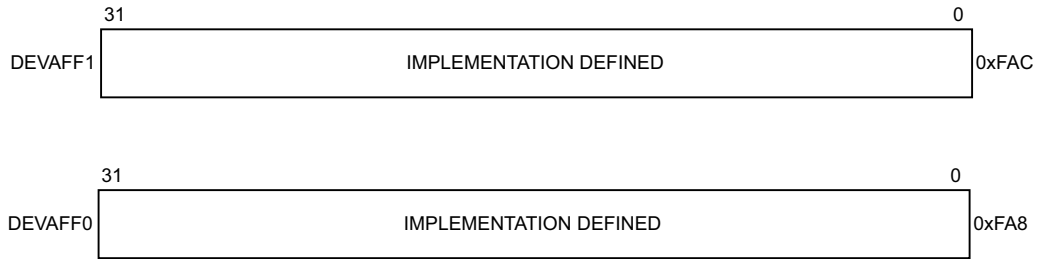

DEVAFF0, bits[31:0]

DEVAFF1, bits[31:0]

RES0.

Accessing DEVAFF0-DEVAFF1

[DEVAFF0-DEVAFF1](#) can be accessed at the following addresses:

Offset	
DEVAFF0	DEVAFF1
0xFA8	0xFAC

C2.6.11 DEVARCH, Device Architecture Register

The [DEVARCH](#) characteristics are:

Purpose

Identifies the architect and architecture of a CoreSight component.

Usage constraints

[DEVARCH](#) is accessible as follows:

Default
RO

Configurations

Included in all implementations.

Attributes

A 32-bit register.

Field Descriptions

The **DEVARCH** bit assignments are:

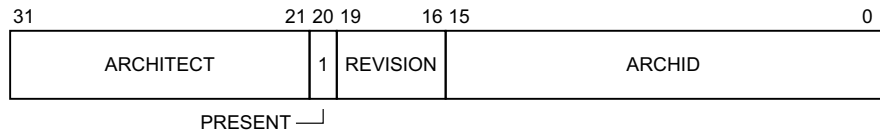

ARCHITECT, bits[31:21]

0x23B Arm.

PRESENT, bit[20]

0b1 Present.

REVISION, bits[19:16]

0x0 Revision 0.

ARCHID, bits[15:0]

For an APv2 MEM-AP, this field has the following value:

0x0A17 MEM-AP.

Accessing DEVARCH

DEVARCH can be accessed at the following address:

Offset

0xFBC

C2.6.12 DEVID, Device Configuration Register

The **DEVID** characteristics are:

Purpose Indicates the capabilities of the component.

Usage constraints **DEVID** is accessible as follows:

Default

RO

Configurations Included in all implementations.

Attributes

A 32-bit register.

Field Descriptions

The **DEVID** bit assignments are:

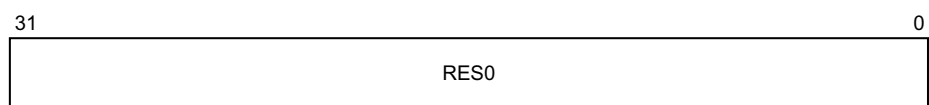

Bits[31:0]

RES0.

Accessing DEVID

DEVID can be accessed at the following address:

Offset
0xFC8

C2.6.13 DEVID1-DEVID2, Device Configuration Registers

The DEVID1-DEVID2 characteristics are:

Purpose

Indicates the capabilities of the component.

Usage constraints

DEVID1-DEVID2 are accessible as follows:

Default
RO

Configurations

Included in all implementations.

Attributes

Two 32-bit registers.

Field Descriptions

The DEVID1-DEVID2 bit assignments are:

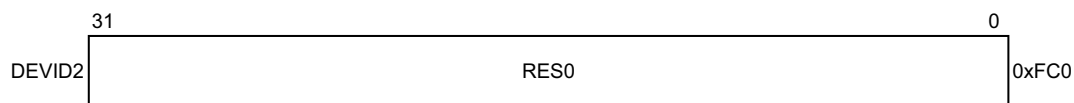
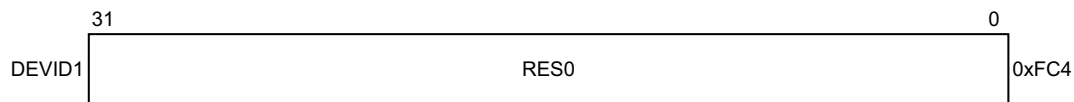

DEVID1, bits[31:0]

DEVID2, bits[31:0]

RES0.

Accessing DEVID1-DEVID2

DEVID1-DEVID2 can be accessed at the following addresses:

Offset	
DEVID1	DEVID2
0xFC4	0xFC0

C2.6.14 DEVTYPE, Device Type Register

The DEVTYPE characteristics are:

Purpose

A debugger can use DEVTYPE to obtain information about a component that has an unrecognized Part number.

Usage constraints

DEVTYPE is accessible as follows:

Default
RO

Configurations

Included in all implementations.

Attributes

A 32-bit register.

Field Descriptions

The DEVTYPE bit assignments are:

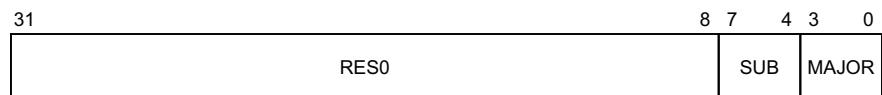

Bits[31:8]

RES0.

SUB, bits[7:4]

0x0 Other, undefined.

MAJOR, bits[3:0]

0x0 Miscellaneous.

Accessing DEVTYPE

DEVTYPE can be accessed at the following address:

Offset
0xFCC

C2.6.15 DRW, Data Read/Write register

The DRW characteristics are:

Purpose

DRW maps the value that is passed in an AP access directly to one or more memory accesses at the address that is specified in the TAR.

The value depends on the access mode:

- In write mode, DRW holds the value to write for the current transfer to the address specified in the TAR.
- In read mode, DRW holds the value that is read in the current transfer from the address that is specified in the TAR.

The AP access does not complete until the memory access, or accesses, complete.

Usage constraints

MEM-AP implementations that include the Large Data Extension enable accessing values with a data type that is larger than the size of DRW, which requires multiple access to DRW to complete a single memory access, as shown in Table C2-11.

Memory accesses that involve multiple DRW accesses have the following limitations:

- The effect of mixing reads and writes in the sequence is UNPREDICTABLE.
- An access to CSW in the middle of a sequence terminates that sequence. The next access to DRW is the first access of a new sequence. If a write sequence is terminated, no memory write is initiated.
- After the first DRW access of the sequence, the effect of accessing any MEM-AP register other than CSW or DRW is UNPREDICTABLE.
- Depending on the value of CSW.AddrInc, the TAR might be incremented after each DRW access. See *Auto-incrementing the Transfer Address Register (TAR)* on page C2-179.

DRW is accessible as follows:

Default
RW

Table C2-11 DRW access behavior for different data type sizes

Size of data type	CSW.Size	Required number of DRW accesses	Read behavior	Write behavior
8 bits ^{a,b}	0b000	1	Each read initiates a memory access and returns the value to be read using byte lanes.	Each write initiates a memory access and writes the value to be written using byte lanes.
16 bits ^{a,b}	0b001	1	Each read initiates a memory access and returns the value to be read.	Each write initiates a memory access and writes the value to be written.
32 bits ^c	0b010	1	Each read initiates a memory access and returns the value to be read.	Each write initiates a memory access and writes the value to be written.

Table C2-11 DRW access behavior for different data type sizes (continued)

Size of data type	CSW.Size	Required number of DRW accesses	Read behavior	Write behavior
64 bits ^d	0b011	2	On first read:	On writes before the last write:
128 bits ^d	0b100	4	<ul style="list-style-type: none"> Initiate a memory access. Return the least significant 32-bit word of the value being read. 	<ul style="list-style-type: none"> Specify the next 32-bit word of the value to be written, starting from the least significant word.
256 bits ^d	0b101	8	On subsequent reads: <ul style="list-style-type: none"> Do not initiate another memory access. Return the next 32-bit word of the value being read. On the first read, the AP access does not complete until the memory access completes.	On last write: <ul style="list-style-type: none"> Do not initiate a memory access. Specify the most significant 32-bit word of the value to be written. Initiate a memory access. On the last write, the AP access does not complete until the memory access completes.

- Support is IMPLEMENTATION DEFINED.
- A single access to DRW might result in multiple memory accesses, depending on the values of CSW.AddrInc. See [Packed transfers on page C2-187](#).
- Supported by all MEM-AP implementations.
- Might be supported by MEM-AP applications that include the Large Data Extension. Support is IMPLEMENTATION DEFINED.

Configurations

A MEM-AP register. The MEM-AP Large Data Extension, described in [MEM-AP Large Data Extension on page C2-193](#), modifies the behavior of this register for accesses with CSW.Size set to a value larger than 0b010.

Attributes

A 32-bit MEM-AP register.

Field Descriptions

The DRW bit assignments are:



Data, bits[31:0]

Data value of the current transfer.

Accessing DRW

DRW can be accessed from the MEM-AP register space:

Offset
0xD0C

C2.6.16 IDR, Identification Register

The **IDR** characteristics are:

Purpose

IDR identifies the AP.

Usage constraints

The value of the register after a reset is IMPLEMENTATION DEFINED.

IDR is accessible as follows:

Default

RO

Configurations

Included in all implementations.

APs that comply with the ADiv6 specification must implement the JEP106 code and provide a value in the REVISION and CLASS fields.

Attributes

A 32-bit read-only register.

Field Descriptions

The **IDR** bit assignments are:

31	28 27	17 16	13 12	8 7	4 3	0
REVISION	DESIGNER	CLASS	RES0	VARIANT	TYPE	

REVISION, bits[31:28]

Starts at 0x0 for the first implementation of an AP design, and increments by one on each major or minor revision of the design. Major design revisions introduce functionality changes, minor revisions are bug fixes.

DESIGNER, bits[27:17]

Code that identifies the designer of the AP.

This field indicates the designer of the AP and not the implementer, except where the two are the same. To obtain a number, or to see the assignment of these codes, contact JEDEC <http://www.jedec.org>.

A JEDEC code takes the following form:

- A sequence of zero or more numbers, all having the value 0x7F.
- A following 8-bit number, that is not 0x7F, and where bit[7] is an odd parity bit. For example, Arm Limited is assigned the code 0x7F 0x7F 0x7F 0x7F 0x3B.

The encoding that is used in the **IDR** is as follows:

- The JEP106 continuation code, **IDR** bits[27:24], is the number of times that 0x7F appears before the final number. For example, for Arm Limited this field is 0x4.
- The JEP106 identification code, **IDR** bits[23:17], equals bits[6:0] of the final number of the JEDEC code. For example, for Arm Limited this field is 0x3B.

Note

The JEP106 codes are assigned by JEDEC to identify the manufacturer of a device. However, in the AP Identification register they identify the designer of the AP.

An implementer of an Arm MEM-AP or JTAG-AP must not change these AP Identification Register values.

Note

For backwards compatibility, debuggers must treat an AP return a JEP106 field of zero as an AP designed by Arm. This encoding was used in early implementations of the ADI. In such an implementation, the REVISION and CLASS fields are also RAZ.

APs that comply with the ADIv6 specification must use the JEP106 code and provide a value in the REVISION and CLASS fields.

CLASS, bits[16:13]

Defines the class of AP. If an AP follows a programmers' model that is defined as part of the ADIv6 specification or extensions to it, it belongs to a class. This field can have the following values:

- 0b0000 No defined class.
- 0b1000 MEM-AP. See [Chapter C2 The Memory Access Port](#).

Bits[12:8]

Reserved, RES0. This field is reserved for future ID register fields. If a debugger reads a non-zero value in this field, it must treat the AP as unidentifiable.

VARIANT, bits[7:4]

Together with the TYPE field, this field identifies the AP implementation. VARIANT differentiates AP implementations that have the same value of TYPE.

Each AP designer must maintain their own list of implementations and associated AP Identification codes.

TYPE, bits[3:0]

Indicates the type of bus, or other connection, that connects to the AP. [Table C2-12](#) lists the possible values of the Type field for an AP designed by Arm. It also shows the value of the CLASS field, which corresponds to bits[16:13] of the [IDR](#), for each value of TYPE.

Together with the VARIANT field, this field identifies the AP implementation. AP implementations that have the same value of TYPE are differentiated by their VARIANT value.

Each AP designer must maintain their own list of implementations and associated AP Identification codes.

Table C2-12 AP Identification types for an AP designed by Arm

TYPE	Connection to AP	CLASS	Notes
0x0	JTAG connection	0b0000	VARIANT field, bits [7:4] of IDR , must be non-zero.
0x1	AMBA AHB3 bus	0b1000	-
0x2	AMBA APB2 or APB3 bus	0b1000	-
0x4	AMBA AXI3 or AXI4 bus, with optional ACE-Lite support	0b1000	-
0x5	AMBA AHB5 bus	0b1000	-
0x6	AMBA APB4 and APB5 bus	0b1000	-

Table C2-12 AP Identification types for an AP designed by Arm (continued)

TYPE	Connection to AP	CLASS	Notes
0x7	AMBA AXI5 bus	0b1000	-
0x8	AMBA AHB5 with enhanced HPROT.	0b1000	-
Other ^a	Reserved	-	-

a. Any value other than 0x0, 0x1, 0x2, or 0x4.

Accessing IDR

IDR can be accessed at the following address:

Offset
0xDFC

C2.6.17 ITCTRL, Integration Mode Control Register

The ITCTRL characteristics are:

Purpose

A component can use this register to dynamically switch between functional mode and integration mode.

In integration mode, topology detection is enabled.

Usage constraints

After switching to integration mode and performing integration tests or topology detection, reset the system to ensure correct behavior of CoreSight and other connected system components.

ITCTRL is accessible as follows:

Default
RW

Configurations

Included in all implementations.

Attributes

A 32-bit register.

Field Descriptions

The [ITCTRL](#) bit assignments are:

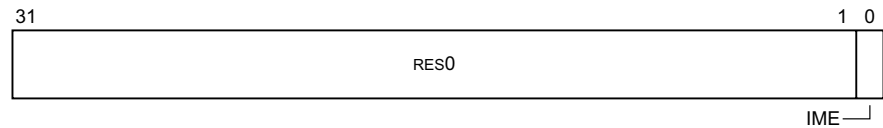

Bits[31:1]

RES0.

IME, bits[0]

Permitted values of IME are:

- 0 The component must enter functional mode.
- 1 The component must enter integration mode, and enable support for topology detection and integration testing.

When no integration functionality is implemented, this field is RES0.

Accessing ITCTRL

[ITCTRL](#) can be accessed at the following address:

Offset

0xF00

C2.6.18 LAR and LSR, Lock Access Register and Lock Status Register

The [LAR and LSR](#) characteristics are:

Purpose

The Software Lock mechanism prevents accidental access to the registers of CoreSight components. For an AP, the lock mechanism is not implemented.

Usage constraints

[LAR and LSR](#) are accessible as follows:

LAR	LSR
WO	RO

Configurations

Included in all implementations.

Attributes

A set of 32-bit registers.

Field Descriptions

The **LAR** and **LSR** bit assignments are:

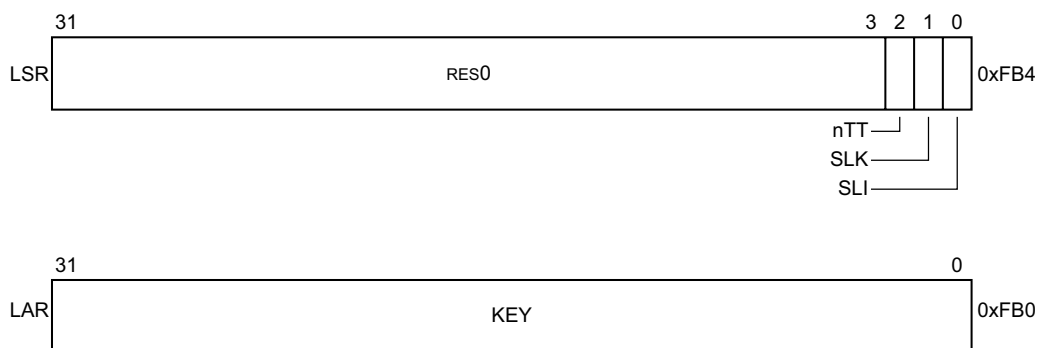

LSR, bits[31:3]

RES0.

nTT, LSR bit[2]

RAZ.

SLK, LSR bit[1]

RAZ.

SLI, LSR bit[0]

RAZ.

KEY, LAR bits[31:0]

WI.

Accessing LAR and LSR

LAR and **LSR** can be accessed at the following addresses:

Offset	
LAR	LSR
0xFB0	0xFB4

C2.6.19 MBT, Memory Barrier Transfer register

The **MBT** register characteristics are:

Purpose

MBT generates a barrier operation on the bus.

Usage constraints

If **CSW.Mode** has a value other than `0b0001`, writes to this register are ignored.

MBT is accessible as follows:

Default

IMPLEMENTATION DEFINED

Configurations

If the Barrier Operation Extension is not implemented, the **MBT** register is reserved, RES0.

The **MBT** register is implemented only if the MEM-AP implementation includes the MEM-AP Barrier Operation Extension, see *MEM-AP Barrier Operation Extension* on page C2-194.

Attributes

A 32-bit MEM-AP register.

The **MBT** register is at offset `0xD20` in the MEM-AP register space.

Other properties of the register are IMPLEMENTATION DEFINED.

Field Descriptions

The **MBT** bit assignments are:



Bits[31:0]

IMPLEMENTATION DEFINED.

Accessing MBT

MBT can be accessed from the MEM-AP register space:

Offset

`0xD20`

C2.6.20 MECID, MECID value register

The **MECID** characteristics are:

Purpose

Provides the **MECID** value for transactions.

Usage constraints

None

MECID is accessible as follows:

Default

RW

Configurations

MECID is present only if **CFG.MECIDWIDTH** != 0b000000. **MECID** is RES0 otherwise.

Attributes

A 32-bit read/write register.

Field Descriptions

The **MECID** bit assignments are:

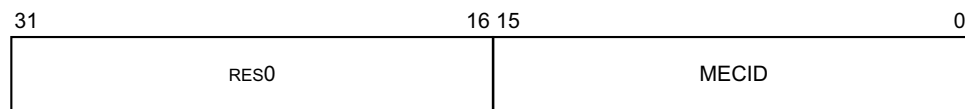

Bits[31:16]

Reserved, RES0.

MECID, bits[15:0]

MECID value.

The size of this field is indicated by **CFG.MECIDWIDTH**. For a size smaller than 16 bits, the upper unused bits are RES0.

This field must be programmed with a **MECID** value that is suitable for the PA space being accessed. For a PA space that does not support MEC, a value of zero is appropriate.

The reset value of this field is 0x0000.

Accessing MECID

MECID can be accessed from the MEM-AP register space:

Offset

0xDDC

C2.6.21 PIDR0-PIDR7, Peripheral Identification Register

This section describes the bit assignments for MEM-AP components.

The [PIDR0-PIDR7](#) characteristics are:

Purpose

Provide information to identify a CoreSight component.

Usage constraints

[PIDR0-PIDR7](#) are accessible as follows:

Default
RO

Configurations

Included in all implementations.

Attributes Eight 32-bit management registers.

Field Descriptions

The [PIDR0-PIDR7](#) bit assignments are:

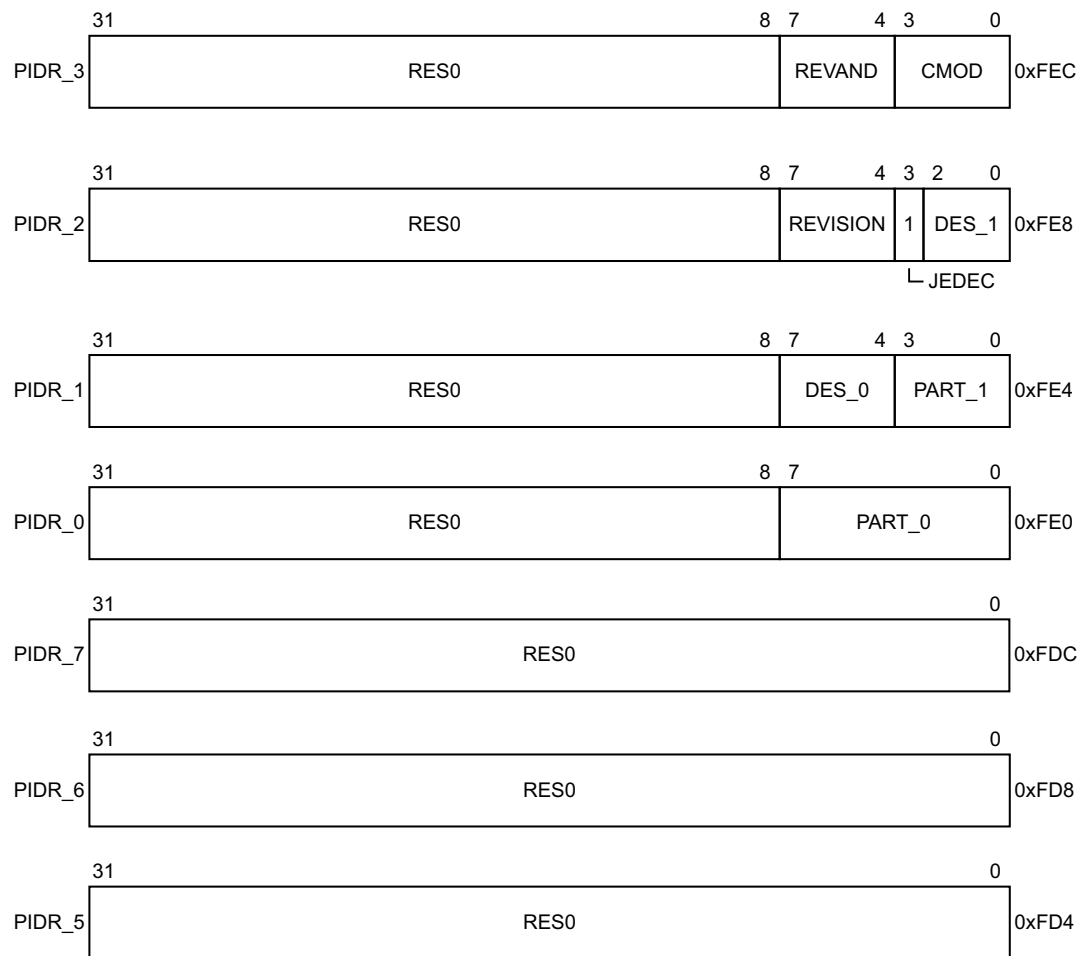



PIDR3 bits[31:8]

RES0.

REVAND, PIDR3 bits[7:4]

See register descriptions in PIDR0-PIDR7 in *Arm® CoreSight™ Architecture Specification*.

CMOD, PIDR3 bits[3:0]

See register descriptions in PIDR0-PIDR7 in *Arm® CoreSight™ Architecture Specification*.

PIDR2 bits[31:8]

RES0.

REVISION, PIDR2 bits[7:4]

See register descriptions in PIDR0-PIDR7 in *Arm® CoreSight™ Architecture Specification*.

JEDEC, PIDR2 bits[3]

0b1 A JEDEC value is used.

DES_1, PIDR2 bits[2:0]

See register descriptions in PIDR0-PIDR7 in *Arm® CoreSight™ Architecture Specification*.

PIDR1 bits[31:8]

RES0.

DES_0, PIDR1 bits[7:4]

See register descriptions in PIDR0-PIDR7 in *Arm® CoreSight™ Architecture Specification*.

PART_1, PIDR1 bits[3:0]

See register descriptions in PIDR0-PIDR7 in *Arm® CoreSight™ Architecture Specification*.

PIDR0 bits[31:8]

RES0.

PART_0, PIDR0 bits[7:0]

See register descriptions in PIDR0-PIDR7 in *Arm® CoreSight™ Architecture Specification*.

PIDR7 bits[31:0]

RES0.

PIDR6 bits[31:0]

RES0.

PIDR5 bits[31:0]

RES0.

PIDR4 bits[31:8]

RES0.

SIZE, PIDR4 bits[7:4]

See register descriptions in PIDR0-PIDR7 in *Arm® CoreSight™ Architecture Specification*.

DES_2, PIDR4 bits[3:0]

See register descriptions in PIDR0-PIDR7 in *Arm® CoreSight™ Architecture Specification*.

Accessing PIDR0-PIDR7

PIDR0-PIDR7 can be accessed at the following address:

Offset							
PIDR0	PIDR1	PIDR2	PIDR3	PIDR4	PIDR5	PIDR6	PIDR7
0xFE0	0xFE4	0xFE8	0xFEC	0xFD0	0xFD4	0xFD8	0xFDC

C2.6.22 TAR, Transfer Address Register

The [TAR](#) characteristics are:

Purpose

The [TAR](#) holds the memory address to be accessed through AP accesses.

Note

The address that is held in the [TAR](#) represents an address in the memory system to which the MEM-AP is connected. It is not an address within the MEM-AP itself.

Configurations and Usage constraints

When using the [DRW](#), the [TAR](#) specifies the memory address to access:

- If the MEM-AP does not support accesses smaller than word, [TAR](#)[1:0] is RES0.
- The contents of the [TAR](#) can be incremented automatically on a successful [DRW](#) access, see [Auto-incrementing the Transfer Address Register \(TAR\)](#) on page C2-179.

When accessing memory through [BD0-BD3](#), [Banked Data registers](#) on page C2-206, bits [3:0] of the [TAR](#) are ignored, and [TAR](#)[63:4] or [TAR](#)[31:4] specifies the base address of the 16-byte block of memory that can be accessed.

The size and reset value of this register are as follows:

Large Physical Address Extension	TAR Size (bits)	Reset Value	
		Least significant word (offset 0xD04)	Most significant word (offset 0xD08)
No	32	UNKNOWN	-
Yes	64	UNKNOWN	0x00000000

[TAR](#) is accessible as follows:

Default

RW

Attributes

A 32-bit or 64-bit MEM-AP register.

Field Descriptions

The **TAR** bit assignments are:

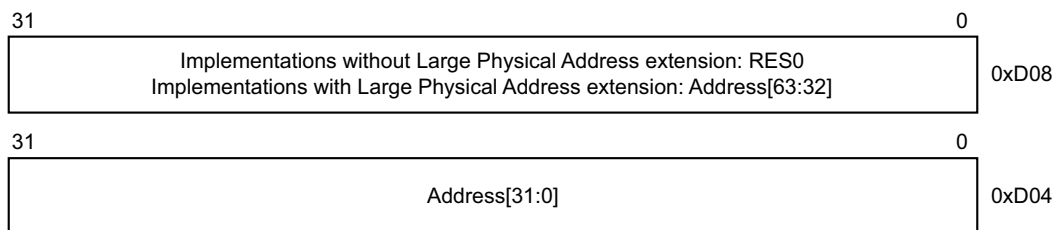

Address[63:32], bits[31:0] of the register word at offset 0xD08

Most significant word of the memory address for the current transfer.

If the MEM-AP implementation does not include the Large Physical Address Extension, this field is RES0.

Address[31:0], bits[31:0] of the register word at offset 0xD04

Least significant word of the memory address for the current transfer.

Accessing TAR

TAR can be accessed from the MEM-AP register space:

Offset	
Least significant word	Most significant word ^a
0xD04	0xD08

a. Applicable only to MEM-AP implementations with a Large Physical Address Extension.

C2.6.23 T0TR, Tag 0 Transfer register

The T0TR characteristics are:

Purpose

Stores tag values for transfers.

Usage constraints

T0TR is accessible as follows:

Default

RW

Configurations

Implemented when the MTE is implemented.

Attributes A 32-bit MEM-AP register.

Field Descriptions

The T0TR bit assignments are:

31	28	27	24	23	20	19	16	15	12	11	8	7	4	3	0																
T7				T6				T5				T4				T3				T2				T1				T0			

T7, bits[31:28]

Allocation tag value.

On reads, holds the Allocation tag value for the most recent system memory read transaction performed with address[6:4] == 0b111.

On writes, holds the Allocation tag value for the next system memory write transaction performed with address[6:4] == 0b111.

This field resets to an architecturally UNKNOWN value on a Reset.

T6, bits[27:24]

Allocation tag value.

On reads, holds the Allocation tag value for the most recent system memory read transaction performed with address[6:4] == 0b110.

On writes, holds the Allocation tag value for the next system memory write transaction performed with address[6:4] == 0b110.

This field resets to an architecturally UNKNOWN value on a Reset.

T5, bits[23:20]

Allocation tag value.

On reads, holds the Allocation tag value for the most recent system memory read transaction performed with address[6:4] == 0b101.

On writes, holds the Allocation tag value for the next system memory write transaction performed with address[6:4] == 0b101.

This field resets to an architecturally UNKNOWN value on a Reset.

T4, bits[19:16]

Allocation tag value.

On reads, holds the Allocation tag value for the most recent system memory read transaction performed with address[6:4] == 0b100.

On writes, holds the Allocation tag value for the next system memory write transaction performed with address[6:4] == 0b100.

This field resets to an architecturally UNKNOWN value on a Reset.

T3, bits[15:12]

Allocation tag value.

On reads, holds the Allocation tag value for the most recent system memory read transaction performed with address[6:4] == 0b011.

On writes, holds the Allocation tag value for the next system memory write transaction performed with address[6:4] == 0b011.

This field resets to an architecturally UNKNOWN value on a Reset.

T2, bits[11:8]

Allocation tag value.

On reads, holds the Allocation tag value for the most recent system memory read transaction performed with address[6:4] == 0b010.

On writes, holds the Allocation tag value for the next system memory write transaction performed with address[6:4] == 0b010.

This field resets to an architecturally UNKNOWN value on a Reset.

T1, bits[7:4]

Allocation tag value.

On reads, holds the Allocation tag value for the most recent system memory read transaction performed with address[6:4] == 0b001.

On writes, holds the Allocation tag value for the next system memory write transaction performed with address[6:4] == 0b001.

This field resets to an architecturally UNKNOWN value on a Reset.

T0, bits[3:0]

Allocation tag value.

On reads, holds the Allocation tag value for the most recent system memory read transaction performed with address[6:4] == 0b000.

On writes, holds the Allocation tag value for the next system memory write transaction performed with address[6:4] == 0b000.

This field resets to an architecturally UNKNOWN value on a Reset.

Accessing T0TR

T0TR can be accessed from the MEM-AP register space:

Offset

0xD30

C2.6.24 TRR, Transfer Response register

The [TRR](#) characteristics are:

Purpose

The [TRR](#) is used to capture whether an error response was received during a transaction, and to clear any logged responses.

Usage constraints

[TRR](#) is accessible as follows:

Default

RW

Configurations

The [TRR](#) is implemented when Error response handling version 1 is implemented, as defined by the value of the [CFG.ERR](#) field. See also [CFG, Configuration register on page C2-209](#).

Attributes A 32-bit MEM-AP register.

Field Descriptions

The [TRR](#) bit assignments are:

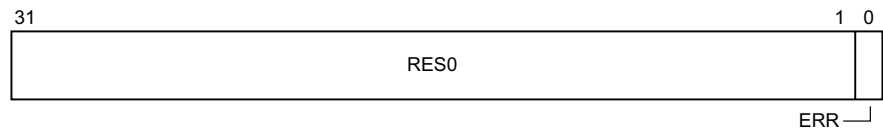

Bits[31:1]

RES0.

ERR, bit[0]

The function of the [TRR](#) depends on whether it is read or written.

On reads, the [TRR](#) returns whether an error was logged:

0b0 No error response was logged.

0b1 An error response was logged.

On writes, the [TRR](#) controls whether the error response is cleared:

0b0 No effect.

0b1 This field is cleared to 0b0.

The reset value of this field is 0b0.

Accessing TRR

[TRR](#) can be accessed from the MEM-AP register space:

Offset

0xD24

Chapter C3

The JTAG Access Port

This chapter describes the implementation of the *JTAG Access Port* (JTAG-AP), and how a JTAG-AP provides a Debug Port connection to one or more JTAG components. The JTAG-AP is an optional component of an ADI implementation.

This chapter contains the following sections:

- [About the JTAG-AP on page C3-244.](#)
- [Operation of the JTAG-AP on page C3-249.](#)
- [The JTAG Engine Byte Command Protocol on page C3-252.](#)
- [JTAG-AP programmers' model on page C3-259.](#)
- [JTAG-AP register descriptions on page C3-261.](#)

———— **Note** —————

[Chapter C1 About the AP](#) gives additional information about APs.

C3.1 About the JTAG-AP

The JTAG-AP is an optional component. It enables up to eight legacy IEEE 1149.1 JTAG scan chains to be connected to the ADI. Each scan chain can contain any number of TAPs, however Arm recommends that only one TAP is connected to each scan chain.

An external debugger accesses a JTAG component, which is connected to a JTAG-AP, through a JTAG scan chain. The debugger accesses this scan chain using APACC accesses to registers in the JTAG-AP. A debugger also has to access JTAG-AP registers to control the JTAG-AP, or to obtain status or identification information from the JTAG-AP.

C3.1.1 Selecting and accessing the JTAG-AP

Figure C3-1 shows the implementation of a JTAG-AP, and how the JTAG-AP connects the DP to up to eight JTAG devices. APACC accesses to the DP are passed to the JTAG-AP.

The method of selecting an AP, and selecting a specific register within the selected AP, is the same for MEM-APs and JTAG-APs, and is summarized in *Selecting and accessing an AP* on page C1-151.

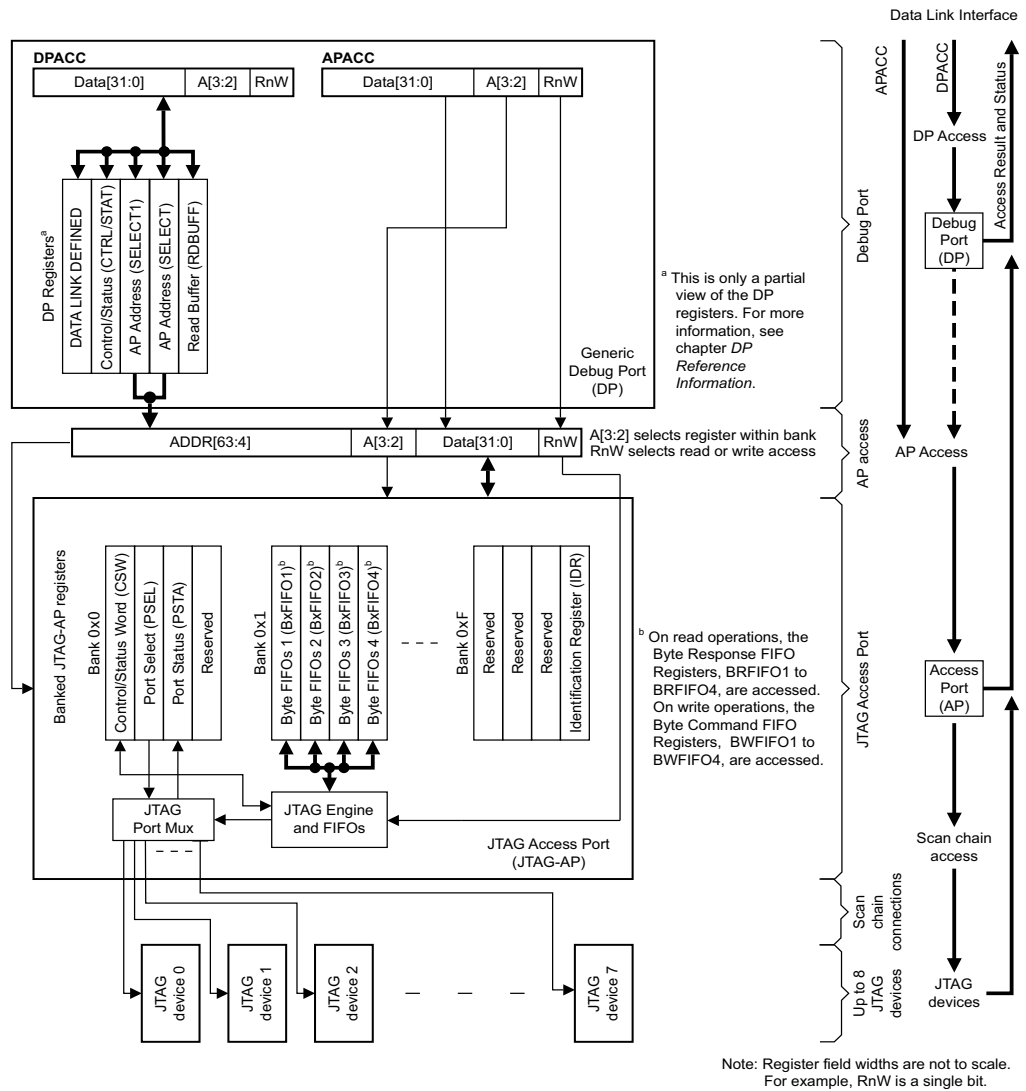

Figure C3-1 JTAG-AP connecting the DP to JTAG devices

JTAG-APs that implement AP architecture version APv1 or earlier cannot be accessed by on-chip software or via functional IO. APv2 incorporates functionality that makes the JTAG control functionality accessible to all debug agents, including on-chip software and debuggers that are connected via functional IO.

In the same way as the APv1 MEM-AP functionality is mapped into the 4KB space of an APv2 MEM-AP, the APv1 JTAG-AP functionality is mapped into the 4KB space of the APv2 JTAG-AP. The full programmers model of the APv2 JTAG-AP that can be used to access the JTAG-APs is described in [JTAG-AP programmers' model on page C3-259](#) and [JTAG-AP register descriptions on page C3-261](#).

C3.1.2 Logical structure of the JTAG-AP

A JTAG-AP comprises:

- It interprets a sequence of command bytes from the Command FIFO.
 - It drives standard JTAG signals to the JTAG Port Multiplexer.
 - It receives the **TDO** signal from the Port Multiplexer.
 - It generates a response and passes it to the Response FIFO.
- The JTAG Port Multiplexer, which multiplexes up to eight JTAG ports to the JTAG Engine. In addition to forwarding the standard JTAG signals to and from each port, it provides control and status signals for each port.
 - Byte Command and Response FIFOs, which enable efficient use of the JTAG Engine.
 - The JTAG-AP registers, which can be divided into three groups:
 - An IR
 - Control and status registers
 - FIFO access registers

Figure C3-2 shows the JTAG-AP structure.

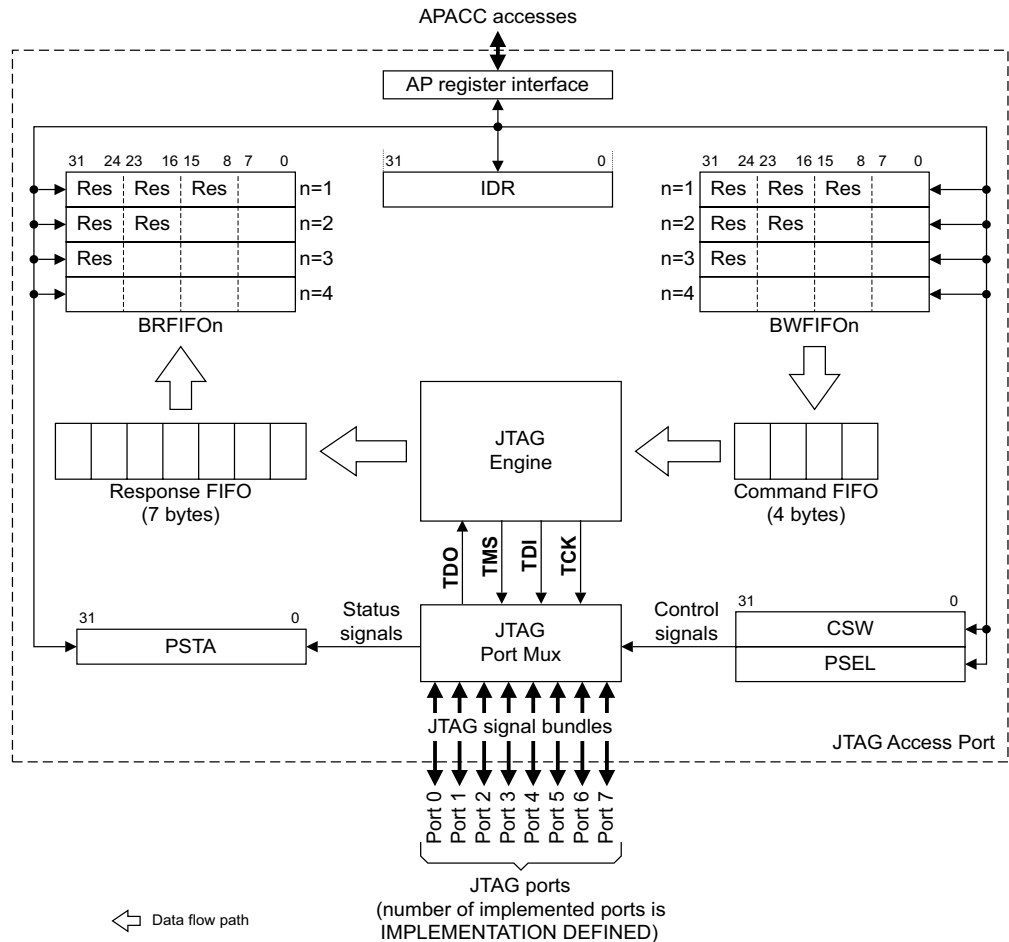

Figure C3-2 Structure of the JTAG Access Port (JTAG-AP)

———— **Note** —————

The following applies to the FIFOs:

- The Response FIFO must be 7 bytes deep.
 - The Command FIFO must be at least 4 bytes deep. Although the Command FIFO can be up to 7 bytes deep, there is unlikely to be any advantage in having a Command FIFO that is larger than 4 bytes.
-

C3.1.3 JTAG port signals

The signal bundle between the JTAG Port Multiplexer and each implemented JTAG port includes:

- The standard IEEE 1149.1 JTAG signals.
- Port control and status signals.

Table C3-1 gives the full signal list, which applies to each implemented port.

Table C3-1 JTAG Access Port JTAG port signals

Signal	Direction ^a	Description	Notes
TCK	Out	Test Clock	JTAG IEEE 1149.1 standard signals.
TMS	Out	Test Mode Select	
TDI	Out	Test Data In	
TDO	In	Test Data Out	
TRST*	Out	Test Reset	Active-LOW JTAG IEEE 1149.1 standard signal.
nSRSTOUT	Out	Subsystem Reset	Active-LOW.
SRSTCONNECTED	In	Subsystem Reset Connected	Tie-off configuration signals to the JTAG Port Multiplexer.
PORTCONNECTED	In	Port Connected	
PORTENABLED	In	Port Enabled	Can be deasserted by the JTAG subsystem, for example when the connected TAP powers down.

a. Signal directions are given relative to the JTAG Port Multiplexer in the JTAG-AP.

C3.2 Operation of the JTAG-AP

The JTAG-AP communicates with the device using standard JTAG signals and scan chains. This operation is controlled by the JTAG Engine. The Engine includes a serializer that takes TDI data out of the Command FIFO and returns TDO data to the Response FIFO, see [Figure C3-2 on page C3-246](#).

The external debugger:

1. Encodes JTAG commands and data into the JTAG Engine Byte Command Protocol, which is described in [The JTAG Engine Byte Command Protocol on page C3-252](#).
2. Writes to the [BWFIFO1-BWFIFO4](#) registers to transfer the encoded JTAG Engine commands and data to the JTAG Command FIFO.
3. Reads from the [BRFIFO1-BRFIFO4](#) registers to collect JTAG TDO in response to the encoded JTAG Engine commands.
4. Decodes the actual TDO data from the response data.

The JTAG Engine provides the connection between stages 2 and 3 of this process.

———— **Note** —————

The JTAG-AP can connect to up to eight JTAG devices. The debugger must write to the [PSEL](#) register to select which JTAG port or ports the JTAG Port Multiplexer connects to the JTAG Engine.

The debugger can start reading data from TDO before completing writing data to TDI, as long as it has completed writing the command header. A debugger can take advantage of this principle to exchange data that exceeds the size of the command and response FIFOs.

For example:

1. The debugger writes two bytes to BWFIFO2, to specify:
 - a. A TDI_TDO scan, with 64 bits of TDI data.
 - b. The TDO data is to be returned to the debugger.
2. The debugger writes a word to BWFIFO4, containing the first 32 bits of TDI data.
3. The debugger reads a word from BRFIFO4, to obtain the first 32 bits of TDO data.
4. The debugger writes another word to BWFIFO4, with the next 32 bits of TDI data.
5. The debugger reads another word from BRFIFO4, to obtain the next 32 bits of TDO data.

This method provides an efficient encapsulation of the JTAG scan chain.

If the requested data is not available, a read of [BRFIFO1-BRFIFO4](#) stalls, as described in [Stalling accesses on page C3-250](#). To reduce the number of stalls that are caused by AP accesses to devices with a slow clock, the debugger can write several bytes of TDI data before attempting to read the first byte of TDO data.

Operation of the JTAG-AP is described in more detail in [The JTAG Engine Byte Command Protocol on page C3-252](#).

C3.2.1 Stalling accesses

AP accesses to JTAG engine FIFOs can be stalled.

As shown in [Figure C3-2 on page C3-246](#), the JTAG Engine FIFOs comprise the following registers:

- The Byte Response FIFO Registers, [BRFIFO1-BRFIFO4](#).
- The Byte Command FIFO Registers, [BWFIFO1-BWFIFO4](#).

The JTAG Engine FIFOs are described in [BRFIFO1-BRFIFO4](#) and can be used to access the JTAG state machine and JTAG scan chains as described in [The JTAG Engine Byte Command Protocol on page C3-252](#).

AP accesses to JTAG-AP registers that do not access the JTAG Engine FIFOs cannot be stalled. As shown in [Figure C3-2 on page C3-246](#), this rule applies to the following registers:

- [CSW](#)
- [PSEL](#)
- [PSTA](#)
- [IDR](#)

A JTAG-AP access can stall in the following situations:

Stalling read accesses

The JTAG-AP can stall read accesses to the Byte Response FIFO Registers, [BRFIFO1-BRFIFO4](#).

Depending which of these registers is targeted, a single register read transfers between 1 and 4 bytes of data from the byte Response FIFO. The register access stalls if the FIFO does not contain enough data. For example, if the Response FIFO only contains 2 bytes of data and a read access is performed to [BRFIFO4](#) to transfer 4 bytes of data, the access stalls and remains stalled until there are 4 bytes of data available in the Response FIFO.

[CSW.RFIFOCNT](#) can be read to find the number of bytes of data that are available in the Response FIFO. A read of the [CSW](#) always completes immediately.

Stalling write accesses

The JTAG-AP can stall write accesses to the Byte Command FIFO Registers, [BWFIFO1-BWFIFO4](#).

Depending which of these registers is targeted, a single register write transfers between 1 and 4 bytes of data into the byte Command FIFO. The register access stalls if the FIFO does not contain enough free space to accept all the write data. For example, if the Command FIFO only has 1 byte free and a write access to [BWFIFO3](#) is performed to transfer 3 bytes into the Command FIFO, the access stalls and remains stalled until the Command FIFO is able to accept the 3 bytes of data.

[CSW.WFIFOCNT](#) can be read to find the number of command bytes in the Command FIFO that are waiting to be processed by the JTAG Engine, which can be used to calculate the number of free bytes in the FIFO. A read of the [CSW](#) always completes immediately.

C3.2.2 Resetting connected JTAG devices or subsystems

Resets of JTAG devices or subsystems that are connected to the JTAG-AP can be triggered with the following signals:

- The [TRST*](#) signal for JTAG Test Resets.
- The [nSRSTOUT](#) signal for subsystem resets.

These signals are controlled by the [CSW.TRST_OUT](#) and [CSW.SRST_OUT](#) fields. A JTAG test reset might have to be clocked out for several [TCK](#) cycles with [TMS HIGH](#) to generate the reset. For more information see [CSW, Control/Status Word Register on page C3-271](#).

C3.2.3 Handling of an ABORT instruction

If a JTAG-AP that supports the ABORT mechanism receives an ABORT instruction while an input transaction that uses the JTAG-AP is in progress:

- The JTAG-AP must respond to the input transaction in finite time.
- If error responses are supported by the JTAG-AP, Arm recommends that an error response is reported when completing the input transaction.

Except for accesses to the [BRFIFO1-BRFIFO4](#) and [BWFIFO1-BWFIFO4](#) registers, Arm recommends that accesses to JTAG-AP registers always complete in a short finite time, because completion does not depend on other system resources.

After an abort, the JTAG-AP is in an UNKNOWN state and it is IMPLEMENTATION DEFINED which JTAG-AP registers are accessible.

Arm recommends that the registers in a JTAG-AP that are not directly related to an outstanding JTAG transaction remain accessible after an abort, to allow a debug agent to diagnose the cause of the problem that caused the abort.

If a JTAG-AP that supports the ABORT mechanism receives an ABORT instruction when no input transaction that uses the JTAG-AP is in progress, the JTAG-AP must ignore the ABORT instruction.

C3.2.4 Pushed transaction and transaction counter support

A JTAG-AP supports pushed transactions and sequences of transactions to the following registers only:

- [PSTA](#)
- [BRFIFO1-BRFIFO4](#)

For more information, see:

- [Pushed-compare and pushed-verify operations on page B1-46.](#)
- [The transaction counter on page B1-45.](#)

C3.3 The JTAG Engine Byte Command Protocol

All JTAG commands, including TMS and TDI data, are written to the JTAG-AP Command FIFO through the interface that is provided by the [BWFIFO1-BWFIFO4](#). To provide high command packing, the JTAG commands are encoded as a byte protocol, and depending on which of the Byte Write FIFO registers is written to, up to four bytes can be written to the FIFO in a single operation. See [BWFIFO1-BWFIFO4, Byte FIFO registers for write access](#) on page C3-265.

Data from the **TDO** signal from the JTAG Port Multiplexer is transferred to the JTAG-AP Response FIFO. The [BWFIFO1-BWFIFO4](#) registers provide an interface to the Response FIFO. See [BRFIFO1-BRFIFO4, Byte FIFO registers for read access](#) on page C3-263.

In the JTAG Engine Byte Command Protocol, all commands are 1 byte (8-bits). [Table C3-2](#) summarizes the commands, and the following sections describe them in more detail. Where appropriate, the command descriptions also describe the TDO data that is produced by the command, and how it is encoded in the Byte Read FIFOs.

Table C3-2 Summary of JTAG Engine Byte Command Protocol

Bits of the Command byte								Opcode	For description, see:
[7]	[6]	[5]	[4]	[3]	[2]	[1]	[0]		
0	Opcode payload							TMS	The encoding of the TMS packet.
1	0	0	Opcode payload					TDI_TDO	The encoding of the TDI_TDO packet on page C3-253.
1	0	1	X	X	X	X	X	Reserved	-
1	1	0	X	X	X	X	X	Reserved	-
1	1	1	X	X	X	X	X	Reserved	-

C3.3.1 The encoding of the TMS packet

The TMS packet is 1 byte. The payload of the packet holds:

- Between 1 and 5 data bits to be sent on **TMS**.
- An indication of whether **TDI** is held at 0 or at 1 while these bits are sent.

While a TMS packet is being executed, no response is captured from **TDO**. The normal use of TMS packets is to move around the JTAG state machine. See [The Debug TAP State Machine \(DBGTAPSM\)](#) on page B3-94.

[Table C3-3](#) shows the possible encodings of a TMS packet.

Table C3-3 TMS packet encodings

Command byte								Notes
[7]	[6]	[5]	[4]	[3]	[2]	[1]	[0]	
0	TDI	1	TMS[4]	TMS[3]	TMS[2]	TMS[1]	TMS[0]	5 bits of TMS data.
0	TDI	0	1	TMS[3]	TMS[2]	TMS[1]	TMS[0]	4 bits of TMS data.
0	TDI	0	0	1	TMS[2]	TMS[1]	TMS[0]	3 bits of TMS data.
0	TDI	0	0	0	1	TMS[1]	TMS[0]	2 bits of TMS data.
0	TDI	0	0	0	0	1	TMS[0]	1 bit of TMS data.

When the JTAG Engine decodes a TMS packet, **TDI** is held at the value indicated by bit [6] while all the TMS data bits are sent. If you have to send **TMS** bits with different **TDI** values, you must use multiple TMS packets.

The TMS data bits are sent LSB first, so in each row of [Table C3-3](#), TMS[0] is the first bit to be sent.

For example, the TMS packet that is used to send the **TMS** bit sequence 1-1-0-1, while keeping **TDI** at 1, is shown in [Figure C3-3](#). As the diagram shows, this sequence of **TMS** signals takes four **TCK** cycles.

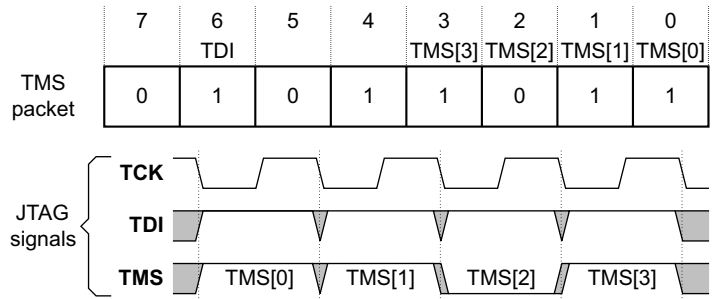

Figure C3-3 TMS packet example with TDI held at 1

To send **TMS** bit sequence 1-0, while keeping **TDI** at 0, the TMS packet is as shown in [Figure C3-4](#). As shown in the diagram, this sequence of **TMS** signals takes two **TCK** cycles.

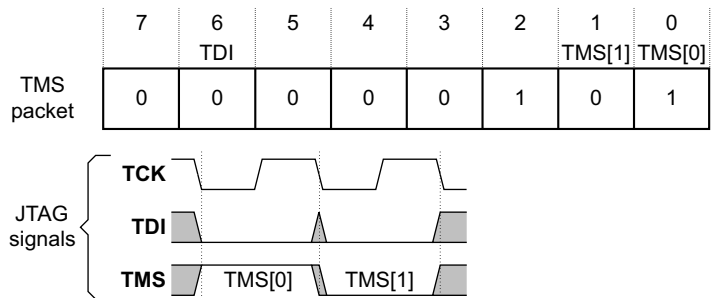

Figure C3-4 TMS packet example with TDI held at 0

C3.3.2 The encoding of the TDI_TDO packet

A **TDI_TDO** packet is a multi-byte packet that is at least 2 bytes long. It comprises:

- The **TDI_TDO** opcode byte.
- A second byte, that contains:
 - For short packets, of fewer than 7 **TDI** bits, the packed **TDI** bits.
 - Otherwise, the length of the packet.
- If required, between 1 and 16 extra bytes containing the **TDI** bits.

The following subsections describe these bytes.

The **TDI_TDO** opcode byte, the first byte of the packet

This byte is the packet header. It indicates the start of a **TDI_TDO** packet, and contains information about the command subtype. [Figure C3-5](#) shows the format of this byte.

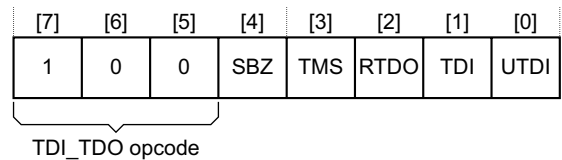

Figure C3-5 TDI_TDO first byte (opcode) format

Bits [3:0] are control bits that define the TDI_TDO subtype. [Table C3-4](#) describes all the bits of the TDI_TDO packet first byte.

Table C3-4 TDI_TDO first byte (opcode) format

Bit	Name	Value ^a	Description
[7]	TDI_TDO	0b1	The value of these bits indicates whether this byte is the first byte of a TDI_TDO packet
[6]		0b0	
[5]		0b0	
[4]	-	SBZ	Reserved, Should Be Zero.
[3]	TMS	-	<p>TMS value to use on the last cycle of the scan:</p> <p>0b0 = TMS LOW on last cycle</p> <p>0b1 = TMS HIGH on last cycle.</p> <p>For all earlier cycles of the scan:</p> <ul style="list-style-type: none"> If the previous TMS or TDI_TDO packet finished with TMS high for the last cycle, it is UNPREDICTABLE whether TMS is HIGH or LOW for this scan. In all other cases, TMS is LOW.
[2]	RTDO	-	<p>Read TDO. This bit determines whether TDO values returned during the scan are captured and placed in the Response FIFO:</p> <p>0b0 = Do not capture TDO</p> <p>0b1 = Capture TDO.</p> <p style="text-align: center;">Caution</p> <p>Do not set this bit to 0b1 if more than one JTAG port is selected and enabled. If you do, the TDO values captured are UNKNOWN.</p>
[1]	TDI	-	<p>TDI value to use throughout the scan if the UTDI bit is 0b1:</p> <p>0b0 = hold TDI signal LOW throughout the scan</p> <p>0b1 = hold TDI signal HIGH throughout the scan</p> <p>The value of the TDI bit is ignored if the UTDI is 0b0.</p>
[0]	UTDI	-	<p>Use TDI bit. This bit determines whether the TDI bits to be used during the scan are supplied in the other bytes of the TDI_TDO packet, or whether the TDI bit, bit [1], specifies the TDI signal to use throughout the scan:</p> <p>0b0 = TDI bits for the scan are supplied in the other bytes of the TDI_TDO packet.</p> <p>0b1 = The TDI bit, bit [1], determines the TDI signal to use throughout the scan.</p> <p>If this bit is 0b1, no TDI data is included in the TDI_TDO packet^b.</p>

- a. Given for bits that have a fixed value for the TDI_TDO first byte.
- b. When the Packed format is used for the second byte of the packet, certain bits of that byte are designated as TDI data bits. If UTDI = 0b1, however, the value of these bits is ignored, as described in *The TDI_TDO length byte, the second byte of the packet* on page C3-255. There is no advantage in using the packed format when UTDI = 0b1, but it is possible to do so.

The TDI_TDO length byte, the second byte of the packet

There are two alternative formats for the second byte of the TDI_TDO packet:

Normal If bit [7] of the TDI_TDO length byte is zero, the byte is in the normal length byte format, and specifies the length of the scan, which can be any value between 1 and 128 bits. Bits [6:0] of the byte give the length in bits of the required scan, minus one, as shown in [Figure C3-6](#).

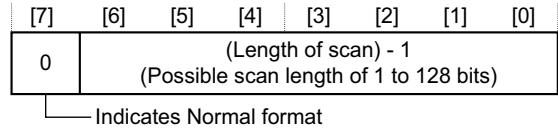

Figure C3-6 TDI_TDO second byte (length byte), normal format

When the TDI_TDO length byte is in the normal format:

- If the UTDI bit of the first byte of the TDI_TDO packet is 0b0, the TDI data for the scan is packed into extra bytes of the packet, that follow the length byte. See [The data bytes, the remaining byte or bytes of the packet on page C3-256](#) for more information.
- If the UTDI bit of the first byte of the TDI_TDO packet is 0b1, no TDI data is required for the scan, and the length byte is the last byte of the packet. If the UTDI bit is 0b1, the TDI_TDO packet is always 2 bytes long.

See [The TDI_TDO opcode byte, the first byte of the packet on page C3-253](#) for more information about the UTDI bit.

Packed If bit [7] of the second byte of the TDI_TDO packet is one, the byte is in the packed length byte format, and contains between 1 and 6 bits of TDI data:

- The length of the required scan is implied by the data in bits [6:0].
- If the UTDI bit of the first byte of the TDI_TDO packet is 0b0, the TDI data for the scan is packed into the least significant bits of the length byte.
- The second byte is the last byte of the TDI_TDO packet, meaning the packet is 2 bytes long.

———— **Note** —————

The packed format of the TDI_TDO length byte can only be used if the required scan contains 6 bits or less.

[Figure C3-7](#) shows the permitted contents of the length byte when the packed format is used.

	[7]	[6]	[5]	[4]	[3]	[2]	[1]	[0]
Scan length = 6 bits	1	1	TDI[5]	TDI[4]	TDI[3]	TDI[2]	TDI[1]	TDI[0]
Scan length = 5 bits	1	0	1	TDI[4]	TDI[3]	TDI[2]	TDI[1]	TDI[0]
Scan length = 4 bits	1	0	0	1	TDI[3]	TDI[2]	TDI[1]	TDI[0]
Scan length = 3 bits	1	0	0	0	1	TDI[2]	TDI[1]	TDI[0]
Scan length = 2 bits	1	0	0	0	0	1	TDI[1]	TDI[0]
Scan length = 1 bit	1	0	0	0	0	0	1	TDI[0]

└── Indicates Packed format

Figure C3-7 TDI_TDO second byte (length byte), packed format

The packed format for the TDI_TDO length byte is summarized in [Table C3-5 on page C3-256](#).

Table C3-5 TDI_TDO length byte, packed format

Scan length (bits)	Must be zero bits	Data start flag	TDI data for scan ^a
6	None	Bit [6] = 0b1	Bits [5:0]
5	Bit [6] = 0b0	Bit [5] = 0b1	Bits [4:0]
4	Bits [6:5] = 0b00	Bit [4] = 0b1	Bits [3:0]
3	Bits [6:4] = 0b000	Bit [3] = 0b1	Bits [2:0]
2	Bits [6:3] = 0b0000	Bit [2] = 0b1	Bits [1:0]
1	Bits [6:2] = 0b00000	Bit [1] = 0b1	Bit [0]

a. When the UTDI bit of the first byte of the TDI_TDO packet is 0b1, the values of these bits are ignored.

When the TDI_TDO length byte is in the packed format:

- If the UTDI bit of the first byte of the TDI_TDO packet is 0b0, the data that is packed into bits[5:0] of the length byte determines the value of the **TDI** signal during the scan. Bit[0] of the length byte always holds TDI[0], meaning that this bit determines the **TDI** signal value for the first **TCK** cycle of the scan.
- If the UTDI bit of the first byte of the TDI_TDO packet is 0b1, the data that is packed into bits[5:0] of the length byte only indicates the length of the required scan, and does not affect the value of the **TDI** signal during the scan. For example, if the complete length byte is 0b10001XXX, referring to [Figure C3-7 on page C3-255](#) shows that a scan of 3 bits is required. The **TDI** signal value, for all three bits, is the TDI value from the first byte of the packet, see [Table C3-3 on page C3-252](#).

See also [The TDI_TDO opcode byte, the first byte of the packet on page C3-253](#).

Note

The packed format can be used when the UTDI bit in the first byte of the packet is 0b1. However, there is no advantage in using the packed format when UTDI = 0b1, because the normal format is easier to use, and the TDI_TDO packet is two bytes long, whichever format is used.

The data bytes, the remaining byte or bytes of the packet

If the TDI_TDO opcode byte is 0x00, and the length byte is in the normal format, the TDI_TDO packet is more than 2 bytes long. In this case:

- Bits[6:0] of the length byte contain the required scan length minus one, in bits.
- The TDI data for the scan is packed into extra bytes of the packet.

The packing of TDI data uses as few bytes as possible, and the least significant bit of TDI data, TDI[0], is always bit[0] of the first data byte. TDI[0] is the **TDI** signal value for the first **TCK** cycle of the scan.

The number of data bytes required is the length of the scan divided by eight, rounded up to an integer value. In the last data byte, any bits that are not required for TDI data must be 0b0. For example, a scan of 21 cycles requires three data bytes, giving a total TDI_TDO packet size of five bytes. [Figure C3-8 on page C3-257](#) shows the formatting of the complete TDI_TDO packet for this example.

	[7]	[6]	[5]	[4]	[3]	[2]	[1]	[0]
TDI_TDO opcode, with TMS = 1 and RTDO = 1	1	0	0	0	1	1	0	0
Length byte, normal format (bit [7] = 0)	0	0	0	1	0	1	0	0
First data byte	TDI[7]	TDI[6]	TDI[5]	TDI[4]	TDI[3]	TDI[2]	TDI[1]	TDI[0]
Second data byte	TDI[15]	TDI[14]	TDI[13]	TDI[12]	TDI[11]	TDI[10]	TDI[9]	TDI[8]
Third data byte	0	0	0	TDI[20]	TDI[19]	TDI[18]	TDI[17]	TDI[16]

Figure C3-8 TDI_TDO formatting example. Complete packet for a scan of 21 TCK cycles

The bit assignments for the bytes shown in [Figure C3-8](#) are:

Byte 1, the opcode byte

- Bits[7:5]** The TDI_TDO opcode, 0b100.
- Bit[3]** The TMS bit. A value of 0b1 indicates that **TMS** must be HIGH for the last cycle of the scan.
- Bit[2]** The RTDO bit. A value of 0b1 indicates that TDO data must be captured during the scan.

Byte 2, the length byte

- Bit[7]** A value of 0b0 indicates that this length byte is in normal format.
- Bits[6:0]** The value of ((length of scan) - 1). This field has the value 0b0010100, which is 20, meaning the scan length is 21 bits.

Bytes 3 and 4, the first and second data bytes

These bytes contain TDI[15:0], the TDI data for the first 16 cycles of the scan.

Byte 5, the third data byte

This byte contains TDI[20:16], the TDI data for the final five cycles of the scan. Any bits that are not required for TDI data must be 0b0, so bits[7:5] = 0b000.

C3.3.3 Response bytes from a TDI_TDO packet

If the Read TDO (RTDO) bit, which is bit[2] of a TDI_TDO packet header, is 0b1, the value of the **TDO** signal is captured for each **TCK** cycle of the scan. This captured TDO data is packed into bytes, and each byte is inserted into the Response FIFO when it is completed.

[Figure C3-8](#) shows a TDI_TDO packet with RTDO = 0b1.

Note

If more than one JTAG port is selected and enabled, the returned TDO values are UNKNOWN.

The number of bytes of TDO data that is inserted in the Response FIFO is the scan length divided by eight, rounded up to an integer value. When the scan length is not an exact multiple of eight, the last byte of returned data is padded with bits having a value of 0b0.

The scan stalls if the Response FIFO is full when a byte of TDO data is ready for insertion.

[Figure C3-9 on page C3-258](#) shows the formatting of the TDO data bytes transferred to the Response FIFO for a scan of 21 **TCK** cycles where TDO capture is enabled.

	[7]	[6]	[5]	[4]	[3]	[2]	[1]	[0]
First data byte transferred to Response FIFO	TDO[7]	TDO[6]	TDO[5]	TDO[4]	TDO[3]	TDO[2]	TDO[1]	TDO[0]
Second data byte transferred to Response FIFO	TDO[15]	TDO[14]	TDO[13]	TDO[12]	TDO[11]	TDO[10]	TDO[9]	TDO[8]
Third data byte transferred to Response FIFO	0	0	0	TDO[20]	TDO[19]	TDO[18]	TDO[17]	TDO[16]

Figure C3-9 TDI_TDO response data formatting example. Scan of 21 TCK cycles

If the RTDO bit is 0b0, no response bytes are placed in the Response FIFO.

For details about the Read TDO (RTDO) bit, see [The TDI_TDO opcode byte, the first byte of the packet on page C3-253](#).

C3.4 JTAG-AP programmers' model

Table C3-6 shows the memory map of the JTAG-AP registers, and indicates where they are described in detail.

[Using the Debug Port to access Access Ports on page A1-28](#) explains how to access AP registers.

All the registers that are listed in Table C3-6 are required in every JTAG-AP APv2 implementation.

Table C3-6 JTAG-AP APv2 programmers' model

Offset	Type	Name	Description
Reserved area			
0x000-0xCFC	-	-	Reserved, RES0
JTAG control registers			
0xD00	RW	CSW	
0xD04	RW	PSEL	
0xD08	RW	PSTA	
0xD0C	-	-	Reserved, RES0
0xD10	RO		Read, single entry
	WO		Write, single entry
0xD14	RO	Read access: BRFIFO1-BRFIFO4	Read, two entries
	WO		Write access: BWFIFO1-BWFIFO4
0xD18	RO		Read, three entries
	WO		Write, three entries
0xD1C	RO		Read, four entries
	WO		Write, four entries
0xD20 - 0xDF8	RES0	-	Reserved
0xDFC	RO	IDR	
Reserved area			
0xE00-0xEFC	-	-	Reserved, RES0.
CoreSight management registers			
0xF00	RW	ITCTRL	See <i>ITCTRL, Integration Mode Control Register</i> on page C3-277.
0xF04-0xF9C	-	-	Reserved, RES0.
0xFA0	RW	CLAIMSET	See <i>CLAIMSET and CLAIMCLR, Claim Tag Set Register and Claim Tag Clear Register</i> on page C3-268.
0xFA4	RW	CLAIMCLR	
0xFA8	RO	DEVAFF0	See <i>DEVAFF0-DEVAFF1, Device Affinity Registers</i> on page C3-273.
0xFAC	RO	DEVAFF1	

Table C3-6 JTAG-AP APv2 programmers' model (continued)

Offset	Type	Name	Description
0xFB0	WO	LAR	See <i>LAR and LSR, Lock Access Register and Lock Status Register</i> on page C3-278.
0xFB4	RO	LSR	
0xFB8	RO	AUTHSTATUS	See <i>AUTHSTATUS, Authentication Status Register</i> on page C3-261.
0xFBC	RO	DEVARCH	See <i>DEVARCH, Device Architecture Register</i> on page C3-274.
0xFC0	RO	DEVID2	See <i>DEVID1-DEVID2, Device Configuration Registers</i> on page C3-275.
0xFC4	RO	DEVID1	
0xFC8	RO	DEVID	See <i>DEVID, Device Configuration Register</i> on page C3-275.
0xFCC	RO	DEVTYPE	See <i>DEVTYPE, Device Type Register</i> on page C3-276.
0xFD0-0xFDC	RO	PIDR4-PIDR7	See <i>PIDR0-PIDR7, Peripheral Identification Register</i> on page C3-279.
0xFE0-0xFEC	RO	PIDR0-PIDR3	
0xFF0-0xFFC	RO	CIDR0-CIDR3	See <i>CIDR0-CIDR3, Component Identification Registers</i> on page C3-267.

C3.5 JTAG-AP register descriptions

This section gives full descriptions of the JTAG-AP registers.

The registers are listed alphabetically by name.

C3.5.1 AUTHSTATUS, Authentication Status Register

The [AUTHSTATUS](#) characteristics are:

Purpose

Reports the required security level and status of the authentication interface. Where functionality changes on a given security level, the change in status must be reported in this register.

The effect of each debug level being enabled or disabled is specific to each AP.

Usage constraints

None.

[AUTHSTATUS](#) is accessible as follows:

Default

RO

Configurations

Included in all implementations.

Attributes

A 32-bit register.

Field Descriptions

The [AUTHSTATUS](#) bit assignments are:

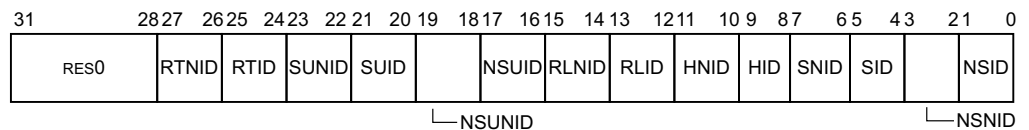

Bits[31:28]

RES0.

RTNID, bits[27:26]

See register descriptions in [AUTHSTATUS, Authentication Status Register](#) on page C1-153.

For a JTAG-AP, this field always takes the value 0b00.

RTID, bits[25:24]

See register descriptions in [AUTHSTATUS, Authentication Status Register](#) on page C1-153.

For a JTAG-AP, this field always takes the value 0b00.

SUNID, bits[23:22]

See register descriptions in [AUTHSTATUS, Authentication Status Register](#) on page C1-153.

For a JTAG-AP, this field always takes the value 0b00.

SUID, bits[21:20]

See register descriptions in [AUTHSTATUS, Authentication Status Register](#) on page C1-153.

For a JTAG-AP, this field always takes the value 0b00.

NSUNID, bits[19:18]

See register descriptions in [AUTHSTATUS, Authentication Status Register](#) on page C1-153.

For a JTAG-AP, this field always takes the value 0b00.

NSUID, bits[17:16]

See register descriptions in [AUTHSTATUS, Authentication Status Register](#) on page C1-153.

For a JTAG-AP, this field always takes the value 0b00.

RLNID, bits[15:14]

See register descriptions in [AUTHSTATUS, Authentication Status Register](#) on page C1-153.

For a JTAG-AP, this field always takes the value 0b00.

RLID, bits[13:12]

See register descriptions in [AUTHSTATUS, Authentication Status Register](#) on page C1-153.

For a JTAG-AP, this field always takes the value 0b00.

HNID, bits[11:10]

See register descriptions in [AUTHSTATUS, Authentication Status Register](#) on page C1-153.

For a JTAG-AP, this field always takes the value 0b00.

HID, bits[9:8]

See register descriptions in [AUTHSTATUS, Authentication Status Register](#) on page C1-153.

For a JTAG-AP, this field always takes the value 0b00.

SNID, bits[7:6]

See register descriptions in [AUTHSTATUS, Authentication Status Register](#) on page C1-153.

For a JTAG-AP, this field always takes the value 0b00.

SID, bits[5:4]

See register descriptions in [AUTHSTATUS, Authentication Status Register](#) on page C1-153.

For a JTAG-AP, this field always takes the value 0b00.

NSNID, bits[3:2]

See register descriptions in [AUTHSTATUS, Authentication Status Register](#) on page C1-153.

For a JTAG-AP, this field always takes the value 0b00.

NSID, bits[1:0]

See register descriptions in [AUTHSTATUS, Authentication Status Register](#) on page C1-153.

For a JTAG-AP, this field always takes the value 0b00.

Accessing AUTHSTATUS

[AUTHSTATUS](#) can be accessed at the following address:

Offset
0xFB8

C3.5.2 BRFIFO1-BRFIFO4, Byte FIFO registers for read access

The [BRFIFO1-BRFIFO4](#) characteristics are:

Purpose

Enable 1, 2, 3, or 4 bytes to be read in parallel from the Response FIFO.

Register	BRFIFO1	BRFIFO2	BRFIFO3	BRFIFO4
Address	0xD10	0xD14	0xD18	0xD1C
Number of bytes read from Response FIFO	1	2	3	4

The JTAG Engine Byte Command protocol that is used for the commands and responses is described in *The JTAG Engine Byte Command Protocol* on page C3-252.

Usage constraints

The [BRFIFO1-BRFIFO4](#) registers are mapped to the same JTAG-AP register addresses as the [BWFIFO1-BWFIFO4](#) registers. The AP accesses the BRFIFO registers on read operations, and the BWFIFO registers on write operations.

An AP transaction that reads more responses than are available in the Response FIFO stalls until enough data is available to match the request. To check the number of response bytes that are available, read the [CSW.RFIFOCNT](#) field before initiating an AP transaction to read from the Response FIFO.

[BRFIFO1-BRFIFO4](#) are accessible as follows:

Default
RO

Configurations

Included in all implementations.

Attributes

A set of four 32-bit RO registers.

Field Descriptions

The [BRFIFO1-BRFIFO4](#) bit assignments are:

BRFIFO1	31 RES0	24 23 RES0	16 15 RES0	8 7 Byte 1	0 0xD10
BRFIFO2	31 RES0	24 23 RES0	16 15 Byte 2	8 7 Byte 1	0 0xD14
BRFIFO3	31 RES0	24 23 Byte 3	16 15 Byte 2	8 7 Byte 1	0 0xD18
BRFIFO4	31 Byte 4	24 23 Byte 3	16 15 Byte 2	8 7 Byte 1	0 0xD1C

BRFIFO1 bits[31:8]

RES0.

Byte 1, BRFIFO1 bits[7:0]

The first byte to be read from the Response FIFO.

BRFIFO2 bits[31:16]

RAZ.

Byte 2, BRFIFO2 bits[15:8]

The second byte to be read from the Response FIFO.

Byte 1, BRFIFO2 bits[7:0]

The first byte to be read from the Response FIFO.

BRFIFO3 bits[31:24]

RAZ.

Byte 3, BRFIFO3 bits[23:16]

The third byte to be read from the Response FIFO.

Byte 2, BRFIFO3 bits[15:8]

The second byte to be read from the Response FIFO.

Byte 1, BRFIFO3 bits[7:0]

The first byte to be read from the Response FIFO.

Byte 4, BRFIFO4 bits[31:24]

The fourth byte to be read from the Response FIFO.

Byte 3, BRFIFO4 bits[23:16]

The third byte to be read from the Response FIFO.

Byte 2, BRFIFO4 bits[15:8]

The second byte to be read from the Response FIFO.

Byte 1, BRFIFO4 bits[7:0]

The first byte to be read from the Response FIFO.

Accessing BRFIFO1-BRFIFO4

BRFIFO1-BRFIFO4 can be accessed from the JTAG-AP register space:

Access	Offset			
	BRFIFO1	BRFIFO2	BRFIFO3	BRFIFO4
Read	0xD10	0xD14	0xD18	0xD1C
Number of bytes read	1	2	3	4

C3.5.3 BWFIFO1-BWFIFO4, Byte FIFO registers for write access

The BWFIFO1-BWFIFO4 characteristics are:

Purpose

Enable 1, 2, 3, or 4 bytes to be written in parallel to the Command FIFO.

Register	BWFIFO1	BWFIFO2	BWFIFO3	BWFIFO4
Address	0xD10	0xD14	0xD18	0xD1C
Number of bytes written to Command FIFO	1	2	3	4

The JTAG Engine Byte Command protocol that is used for the commands and responses is described in *The JTAG Engine Byte Command Protocol* on page C3-252.

Usage constraints

The BWFIFO1-BWFIFO4 registers are mapped to the same JTAG-AP register addresses as the BRFIFO1-BRFIFO4 registers. The AP accesses the BRFIFO n registers on read operations, and the BWFIFO n registers on write operations.

An AP transaction that writes more commands than there is space for in the Command FIFO stalls until there is enough space in the Command FIFO. Space in the Command FIFO is freed as commands are executed by the JTAG Engine. To check the number of commands already present in the Command FIFO, read the CSW.WFIFOCNT field before initiating an AP transaction to write to the Command FIFO. The number of additional commands you can write to the FIFO can be calculated by subtracting the return value from the size of the Command FIFO.

BWFIFO1-BWFIFO4 are accessible as follows:

Default

WO

Configurations

Included in all implementations.

Attributes

A set of four 32-bit WO registers.

Field Descriptions

The BWFIFO1-BWFIFO4 bit assignments are:

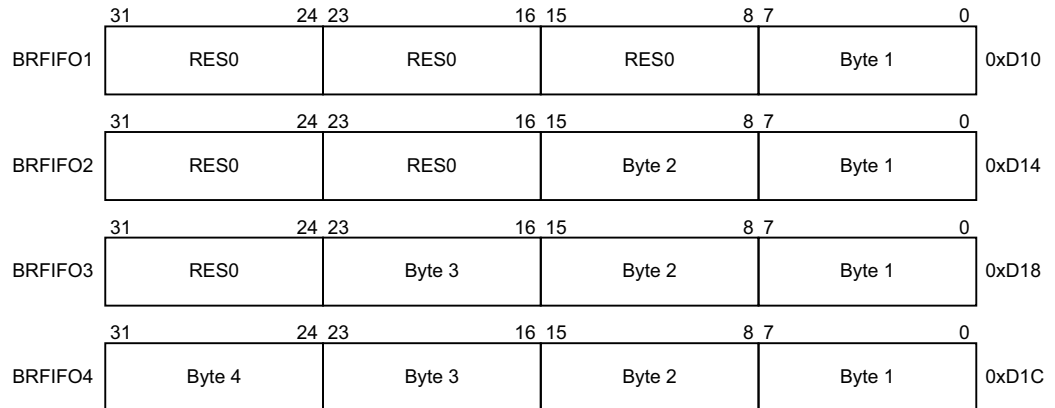

BWFIFO1 bits[31:8]

RES0.

Byte 1, BWFIFO1 bits[7:0]

The first byte to be written to the Command FIFO.

BWFIFO2 bits[31:16]

RES0.

Byte 2, BWFIFO2 bits[15:8]

The second byte to be written to the Command FIFO.

Byte 1, BWFIFO2 bits[7:0]

The first byte to be written to the Command FIFO.

BWFIFO3 bits[31:24]

RES0.

Byte 3, BWFIFO3 bits[23:16]

The third byte to be written to the Command FIFO.

Byte 2, BWFIFO3 bits[15:8]

The second byte to be written to the Command FIFO.

Byte 1, BWFIFO3 bits[7:0]

The first byte to be written to the Command FIFO.

Byte 4, BWFIFO4 bits[31:24]

The fourth byte to be written to the Command FIFO.

Byte 3, BWFIFO4 bits[23:16]

The third byte to be written to the Command FIFO.

Byte 2, BWFIFO4 bits[15:8]

The second byte to be written to the Command FIFO.

Byte 1, BWFIFO4 bits[7:0]

The first byte to be written to the Command FIFO.

Accessing BWFIFO1-BWFIFO4

BWFIFO1-BWFIFO4 can be accessed from the JTAG-AP register space:

Access	Offset			
	BWFIFO1	BWFIFO2	BWFIFO3	BWFIFO4
Write	0xD10	0xD14	0xD18	0xD1C
Number of bytes written	1	2	3	4

C3.5.4 CIDR0-CIDR3, Component Identification Registers

This section describes the bit assignments for JTAG AP components.

The [CIDR0-CIDR3](#) characteristics are:

Purpose

Provide information to identify a CoreSight component.

Usage constraints

[CIDR0-CIDR3](#) are accessible as follows:

Default
RO

Configurations

Included in all implementations.

Attributes

Four 32-bit management registers.

Field Descriptions

The [CIDR0-CIDR3](#) bit assignments are:

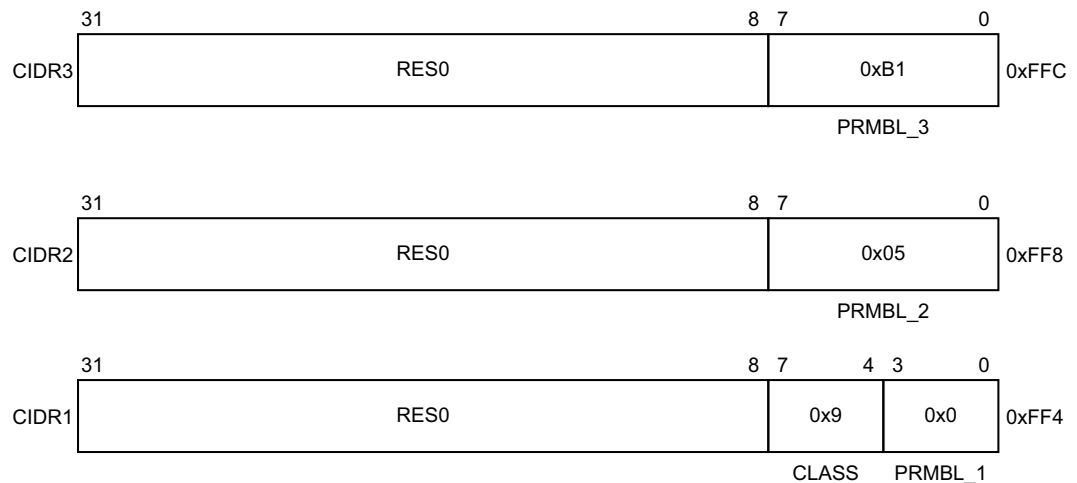

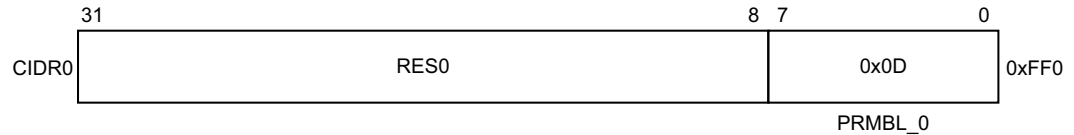

CIDR3 bits[31:8]

RES0.

PRMBL_3, CIDR3 bits[7:0]

0xB1.

CIDR2 bits[31:8]

RES0.

PRMBL_2, CIDR2 bits[7:0]

0x05.

CIDR1 bits[31:8]

RES0.

CLASS, CIDR1 bits[7:4]

0x9 CoreSight component.

PRMBL_1, CIDR1 bits[3:0]

0x0.

CIDR0 bits[31:8]

RES0.

PRMBL_0, CIDR0 bits[7:0]

0x0D.

Accessing CIDR

[CIDR0-CIDR3](#) can be accessed at the following address:

Offset			
CIDR0	CIDR1	CIDR2	CIDR3
0xFF0	0xFF4	0xFF8	0xFFC

C3.5.5 CLAIMSET and CLAIMCLR, Claim Tag Set Register and Claim Tag Clear Register

The [CLAIMSET](#) and [CLAIMCLR](#) characteristics are:

Purpose

[CLAIMSET](#) and [CLAIMCLR](#) are used to communicate between different debug agents and to claim usage of an APv2 AP. For detailed information, see [CLAIMSET and CLAIMCLR, Claim Tag Set Register and Claim Tag Clear Register](#) on page C1-156.

Usage constraints

CLAIMSET and CLAIMCLR are accessible as follows:

CLAIMSET	CLAIMCLR
RW	RW

Configurations

Included in all implementations.

Attributes

Two 32-bit registers.

Field Descriptions

The CLAIMSET and CLAIMCLR bit assignments are:

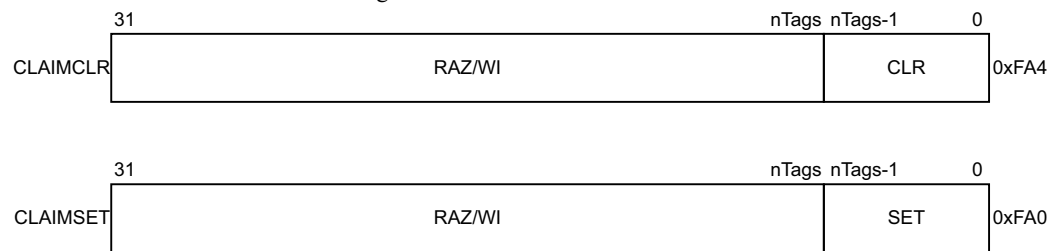

CLAIMCLR bits[31:nTags]

RAZ/WI

CLR, CLAIMCLR bits[nTags-1:0]

The size of this field, nTags, is IMPLEMENTATION DEFINED, and equals the number of bits set in CLAIMSET.

Allowed values of CLR[n] are:

- Write 0** No effect.
- Write 1** Clear the claim tag for bit[n].
- Read 0** The claim tag bit is not set.
- Read 1** The claim tag bit is set.

CLAIMSET bits[31:nTags]

RAZ/WI

SET, CLAIMSET bits[nTags-1:0]

The size of this field, nTags, is IMPLEMENTATION DEFINED, and equals the number of claim bits that are implemented.

Permitted values of SET[n] are:

- Write 0** No effect.
- Write 1** Set the claim tag for bit[n].
- Read 0** The claim tag that is represented by bit[n] is not implemented.
- Read 1** The claim tag that is represented by bit[n] is implemented.

Accessing CLAIMSET and CLAIMCLR

CLAIMSET and CLAIMCLR can be accessed at the following addresses:

Offset	
CLAIMSET	CLAIMCLR
0xFA0	0xFA4

C3.5.6 CSW, Control/Status Word Register

The CSW characteristics are:

Purpose

CSW configures and controls transfers through the JTAG interface.

Usage constraints

Several fields in the register are read-only, see *Field Descriptions*.

CSW is accessible as follows:

Default

RW

Configurations

Included in all implementations.

Attributes

A 32-bit read/write register.

Field Descriptions

The CSW bit assignments are:

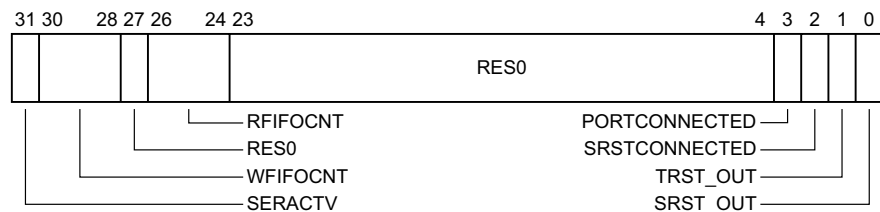

SERACTV, bit[31]

JTAG Engine active.

This read-only field can have one of the following values:

0b0 JTAG Engine is inactive, provided WFIFOCNT is also 0b0.

0b1 JTAG Engine is processing commands from the Command FIFO.

———— Note ————

The JTAG Engine is only guaranteed to be inactive if both SERACTV and WFIFOCNT are zero.

The reset value of this field is 0b0.

WFIFOCNT, bits[30:28]

Command FIFO outstanding byte count.

This read-only field returns the number of command bytes held in the Command FIFO that have yet to be processed by the JTAG Engine. The reset value is 0b000.

Bit[27]

Reserved, RES0.

RFIFOCNT, bits[26:24]

Response FIFO outstanding byte count.

This read-only field returns the number of bytes of response data available in the Response FIFO.
The reset value of this field is 0b000.

Bits[23:4]

Reserved, RES0.

PORTCONNECTED, bit[3]

Selected ports connected.

This read-only field returns the logical AND of the **PORTCONNECTED** signals from all ports that are currently selected.

This field is read-only. The reset value depends on the state of the connected signals when the register is read.

SRSTCONNECTED, bit[2]

Selected ports reset connected.

This read-only field returns the logical AND of the **SRSTCONNECTED** signals from all ports that are currently selected.

The reset value depends on the state of the connected signals when the register is read.

TRST_OUT, bit[1]

This field drives the **TRST*** signal for the currently selected port or ports.

0b0 Deassert **TRST*** HIGH.

0b1 Assert **TRST*** LOW.

———— Note —————

The **TRST*** signal is active LOW: when TRST_OUT has the value 0b1, the **TRST*** output is LOW.

TRST_OUT does not self-reset: it must be cleared to 0b0 by a software write. The reset value is 0b0.

Although TRST_OUT drives the **TRST*** signal, writing to this field only causes the field value to change. It might be necessary to clock the devices connected to the selected JTAG ports using **TCK**, to enable the devices to recognize the change on **TRST***:

1. Write 1 to the **CSW.TRST_OUT** bit, to specify that **TRST*** must be asserted LOW.
2. Drive a sequence of at least five **TMS = 1** clocks from the JTAG Engine by issuing the command 0b00111111 to the JTAG Engine. This sequence guarantees that the TAP enters the Test-Logic/Reset state, even if it has no **TRST*** connection.
3. Write 0b0 to **CSW.TRST_OUT**, to make sure that the **TRST*** signal is HIGH on subsequent **TCK** cycles.

If the JTAG connection is not clocked in this way while **TRST*** is asserted LOW, some or all TAPs might not reset.

SRST_OUT, bit[0]

This field drives the **nSRSTOUT** signal for the port or ports that are currently selected, and can have one of the following values:

0b0 Deassert **nSRSTOUT** HIGH.

0b1 Assert **nSRSTOUT** LOW.

———— Note —————

The **nSRSTOUT** signal is active LOW: when SRST_OUT has the value 0b1, the **nSRSTOUT** output is LOW.

SRST_OUT does not self-reset: it must be cleared to 0b0 by a software write. The reset value is 0b0.

Accessing CSW

CSW can be accessed from the JTAG-AP register space:

Offset
0xD00

C3.5.7 DEVAFF0-DEVAFF1, Device Affinity Registers

The DEVAFF0-DEVAFF1 characteristics are:

Purpose

Enables a debugger to determine whether two components have an affinity with each other.

Usage constraints

DEVAFF0-DEVAFF1 are accessible as follows:

Default
RO

Configurations

Included in all implementations.

Attributes

Two 32-bit registers.

Field Descriptions

The DEVAFF0-DEVAFF1 bit assignments are:



DEVAFF0, bits[31:0]

DEVAFF1, bits[31:0]

IMPLEMENTATION DEFINED.

Accessing DEVAFF0-DEVAFF1

DEVAFF0-DEVAFF1 can be accessed at the following addresses:

Offset	
DEVAFF0	DEVAFF1
0xFA8	0xFAC

C3.5.8 DEVARCH, Device Architecture Register

The **DEVARCH** characteristics are:

Purpose

Identifies the architect and architecture of a CoreSight component.

Usage constraints

DEVARCH is accessible as follows:

Default
RO

Configurations

Included in all implementations.

Attributes

A 32-bit register.

Field Descriptions

The **DEVARCH** bit assignments are:

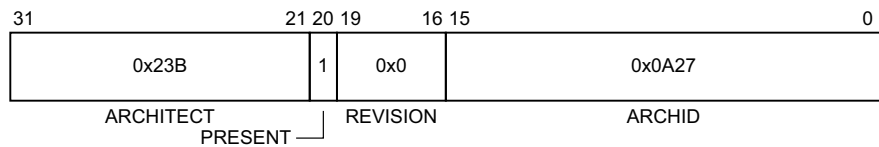

ARCHITECT, bits[31:21]

0x23B Arm.

PRESENT, bit[20]

0b1 Present.

REVISION, bits[19:16]

0x0 Revision 0.

ARCHID, bits[15:0]

For an APv2 JTAG-AP, this field has the following value:

0x0A27 JTAG-AP.

Accessing DEVARCH

DEVARCH can be accessed at the following address:

Offset
0xFBC

C3.5.9 DEVID, Device Configuration Register

The **DEVID** characteristics are:

Purpose

Indicates the capabilities of the component.

Usage constraints

DEVID is accessible as follows:

Default

RO

Configurations

Included in all implementations.

Attributes

A 32-bit register.

Field Descriptions

The **DEVID** bit assignments are:

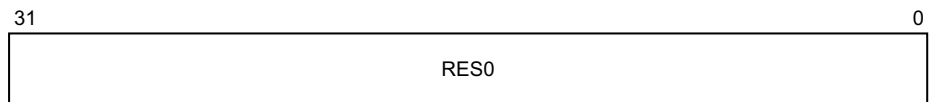

Bits[31:0]

RES0.

Accessing DEVID

DEVID can be accessed at the following address:

Offset

0xFC8

C3.5.10 DEVID1-DEVID2, Device Configuration Registers

The **DEVID1-DEVID2** characteristics are:

Purpose

Indicates the capabilities of the component.

Usage constraints

DEVID1-DEVID2 are accessible as follows:

Default

RO

Configurations

Included in all implementations.

Attributes

Two 32-bit registers.

Field Descriptions

The [DEVID1-DEVID2](#) bit assignments are:

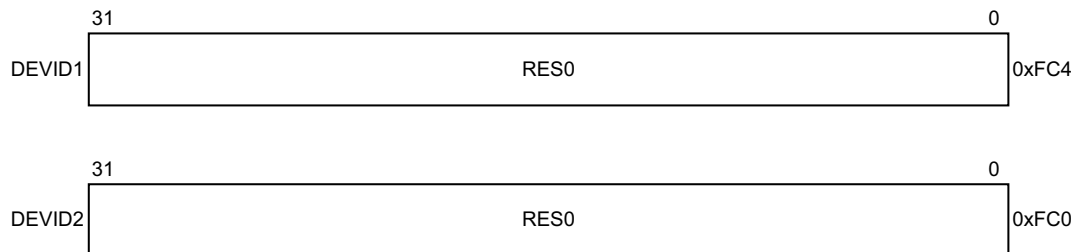

DEVID1, bits[31:0]

DEVID2, bits[31:0]

RES0.

Accessing DEVID1-DEVID2

[DEVID1-DEVID2](#) can be accessed at the following addresses:

Offset	
DEVID1	DEVID2
0xFC4	0xFC0

C3.5.11 DEVTYPE, Device Type Register

The [DEVTYPE](#) characteristics are:

Purpose

A debugger can use [DEVTYPE](#) to obtain information about a component that has an unrecognized Part number.

Usage constraints

[DEVTYPE](#) is accessible as follows:

Default
RO

Configurations

Included in all implementations.

Attributes

A 32-bit register.

Field Descriptions

The [DEVTYPE](#) bit assignments are:

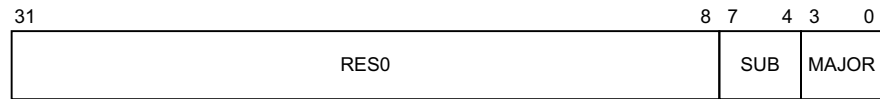

Bits[31:8]

RES0.

SUB, bits[7:4]

0x0 Other, undefined.

MAJOR, bits[3:0]

0x0 Miscellaneous.

Accessing DEVTYPE

[DEVTYPE](#) can be accessed at the following address:

Offset

0xFCC

C3.5.12 ITCTRL, Integration Mode Control Register

The [ITCTRL](#) characteristics are:

Purpose

A component can use [ITCTRL](#) to dynamically switch between functional mode and integration mode.

In integration mode, topology detection is enabled.

Usage constraints

After switching to integration mode and performing integration tests or topology detection, reset the system to ensure correct behavior of CoreSight and other connected system components.

[ITCTRL](#) is accessible as follows:

Default

RW

Configurations

Included in all implementations.

Attributes

A 32-bit register.

Field Descriptions

The [ITCTRL](#) bit assignments are:

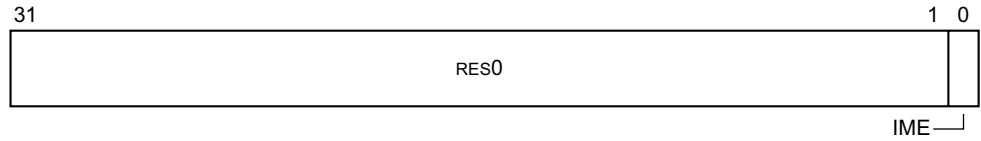

Bits[31:1]

RES0.

IME, bits[0]

Permitted values of IME are:

- 0 The component must enter functional mode.
 - 1 The component must enter integration mode and enable support for topology detection and integration testing.
- When no integration functionality is implemented, this field is RES0.

Accessing ITCTRL

[ITCTRL](#) can be accessed at the following address:

Offset
0xF00

C3.5.13 LAR and LSR, Lock Access Register and Lock Status Register

The [LAR](#) and [LSR](#) characteristics are:

Purpose

The Software Lock mechanism prevents accidental access to the registers of CoreSight components. For an AP, the lock mechanism is not implemented.

Usage constraints

[LAR](#) and [LSR](#) are accessible as follows:

LAR	LSR
WO	RO

Configurations

Included in all implementations.

Attributes

A set of 32-bit registers.

Field Descriptions

The **LAR** and **LSR** bit assignments are:

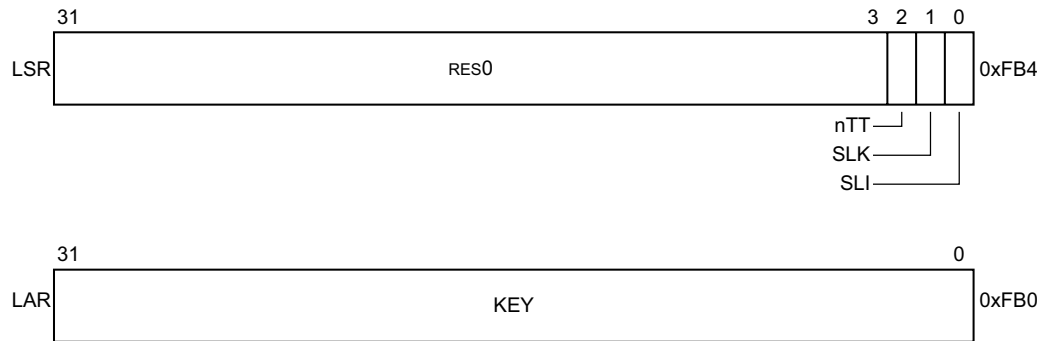

LSR, bits[31:3]

RES0.

nTT, LSR bit[2]

RAZ.

SLK, LSR bit[1]

RAZ.

SLI, LSR bit[0]

RAZ.

KEY, LAR bits[31:0]

WI.

Accessing LAR and LSR

LAR and **LSR** can be accessed at the following addresses:

Offset	
LAR	LSR
0xFB0	0xFB4

C3.5.14 PIDR0-PIDR7, Peripheral Identification Register

This section describes the bit assignments for JTAG AP components. For a full description of the PIDR registers, see [PIDR0-PIDR7, Peripheral Identification Register](#).

The **PIDR0-PIDR7** characteristics are:

Purpose

Provide information to identify a CoreSight component.

Usage constraints

PIDR0-PIDR7 are accessible as follows:

Default
RO

Configurations

Included in all implementations.

Attributes

Eight 32-bit management registers.

Field Descriptions

The [PIDR0-PIDR7](#) bit assignments are:

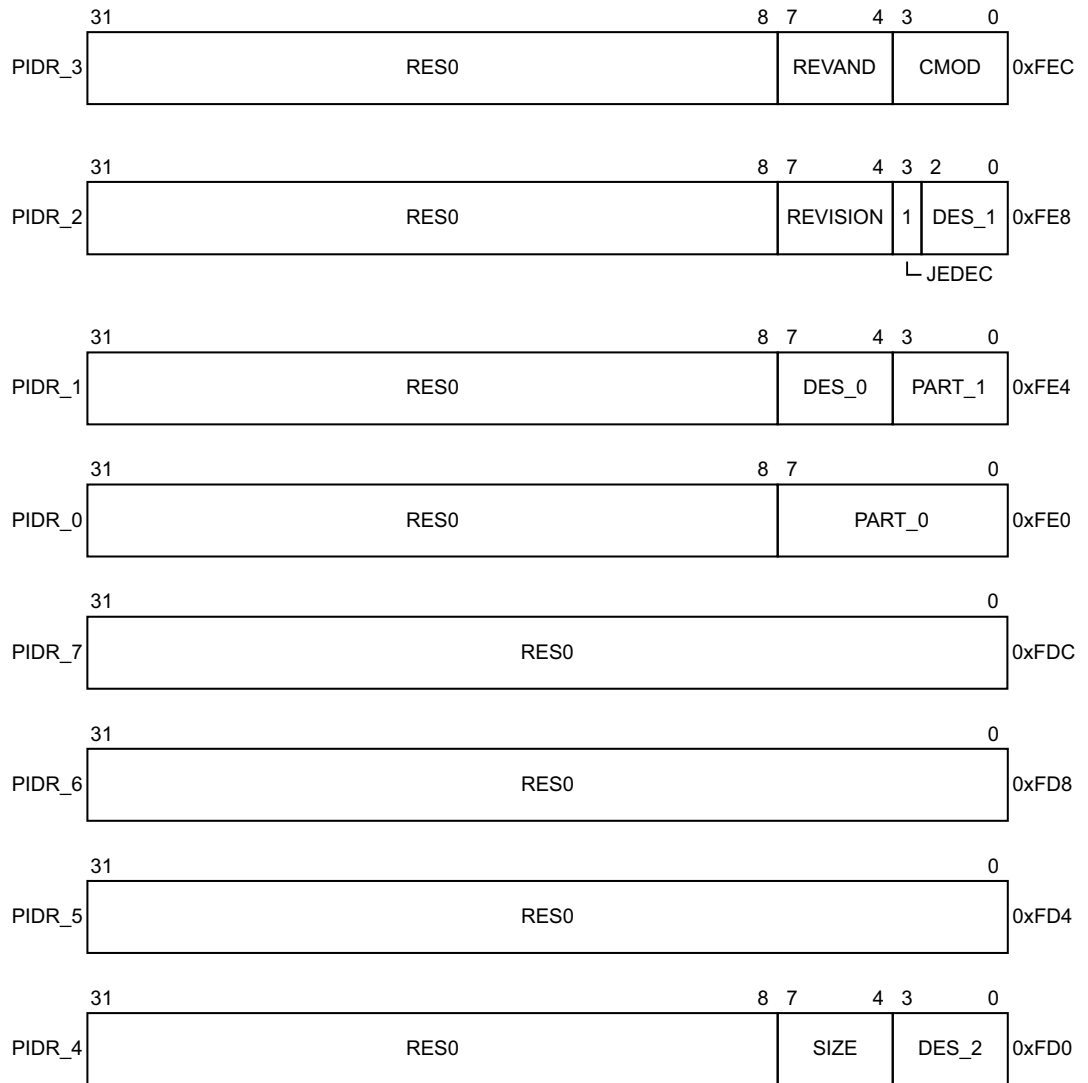

PIDR3 bits[31:8]

RES0.

REVAND, PIDR3 bits[7:4]

See register descriptions in PIDR0-PIDR7 in *Arm® CoreSight™ Architecture Specification*.

CMOD, PIDR3 bits[3:0]

See register descriptions in PIDR0-PIDR7 in *Arm® CoreSight™ Architecture Specification*.

PIDR2 bits[31:8]

RES0.

REVISION, PIDR2 bits[7:4]

See register descriptions in PIDR0-PIDR7 in *Arm® CoreSight™ Architecture Specification*.

JEDEC, PIDR2 bits[3]

0b1 A JEDEC value is used.

DES_1, PIDR2 bits[2:0]

See register descriptions in PIDR0-PIDR7 in *Arm® CoreSight™ Architecture Specification*.

PIDR1 bits[31:8]

RES0.

DES_0, PIDR1 bits[7:4]

See register descriptions in PIDR0-PIDR7 in *Arm® CoreSight™ Architecture Specification*.

PART_1, PIDR1 bits[3:0]

See register descriptions in PIDR0-PIDR7 in *Arm® CoreSight™ Architecture Specification*.

PIDR0 bits[31:8]

RES0.

PART_0, PIDR0 bits[7:0]

See register descriptions in PIDR0-PIDR7 in *Arm® CoreSight™ Architecture Specification*.

PIDR7 bits[31:0]

RES0.

PIDR6 bits[31:0]

RES0.

PIDR5 bits[31:0]

RES0.

PIDR4 bits[31:8]

RES0.

SIZE, PIDR4 bits[7:4]

See register descriptions in PIDR0-PIDR7 in *Arm® CoreSight™ Architecture Specification*.

DES_2, PIDR4 bits[3:0]

See register descriptions in PIDR0-PIDR7 in *Arm® CoreSight™ Architecture Specification*.

Accessing PIDR0-PIDR7

[PIDR0-PIDR7](#) can be accessed at the following address:

Offset							
PIDR0	PIDR1	PIDR2	PIDR3	PIDR4	PIDR5	PIDR6	PIDR7
0xFE0	0xFE4	0xFE8	0xFEC	0xFD0	0xFD4	0xFD8	0xFDC

C3.5.15 PSEL, Port Select register

The PSEL characteristics are:

Purpose

PSEL selects one or more JTAG ports to be driven by the JTAG Engine.

Usage constraints

PSEL must only be written to when the JTAG Engine is inactive and the WFIFO is empty. Writing PSEL at any other time has UNPREDICTABLE results, so before writing to PSEL you must read the JTAG-AP CSW and make sure that the SERACTV and WFIFOCNT fields are both zero.

The reset value of PSEL is UNKNOWN.

PSEL is accessible as follows:

Default
RW

Configurations

Available in all implementations.

Attributes

A 32-bit read/write register.

Field Descriptions

The PSEL bit assignments are:



Bits[31:8]

Reserved, RES0.

PSEL7-PSEL0, bits[7:0]

Select control for the JTAG ports.

The possible values of each of the PSEL_n fields are:

0b0 JTAG port *n* is not selected.

0b1 JTAG port *n* is selected.

If JTAG port *n* is not connected to the JTAG-AP, it is IMPLEMENTATION DEFINED whether PSEL_n is read/write or RES0.

Note

JTAG port *n* is enabled only if all the following are true:

- The port is connected to the JTAG-AP.
- PSEL_n is 0b1.
- The PORTENABLED signal from the port to the JTAG-AP is asserted HIGH.

When more than one JTAG port is selected in the PSEL Register:

- The same values for TDI, TMS, TRST*, and nSRSTOUT are driven to all selected ports.
- The return values from TDO are UNKNOWN.

Using the normal, serially connected model for JTAG, IR updates are always made in parallel, which enables updating multiple TAPs in parallel. This update mechanism can be useful, for example to provide synchronized behavior.

Because each JTAG port can contain multiple TAPs connected in series, the process for updating TAPs in parallel is as follows:

1. Scan each JTAG port in turn, by selecting each port in turn in the **PSEL** register. When scanning a port, leave the required TAP in the TAP Exit1 or Exit2 state.
2. When all ports have been scanned in this way, write to **PSEL** again to select all the required ports.
3. Scan through the TAP Update state. All the TAPs are updated synchronously.

Accessing PSEL

PSEL can be accessed from the JTAG-AP register space:

Offset

0xD04

C3.5.16 PSTA, Port Status Register

The **PSTA** characteristics are:

Purpose

PSTA indicates whether a connected and selected JTAG port has been disabled, even if it has been re-enabled.

Usage constraints

Writing a value with any non-zero bits to **PSTA** when the JTAG-AP engine is not idle is UNPREDICTABLE. The JTAG-AP Engine is idle when both **CSW.SERACTV** and **CSW.WFIFOCNT** are zero.

The reset value of **PSTA0-PSTA7** is **0b0**.

PSTA is accessible as follows:

Default
RW

Configurations

A JTAG-AP register.

Attributes

A 32-bit read/write register.

Field Descriptions

The **PSTA** bit assignments are:

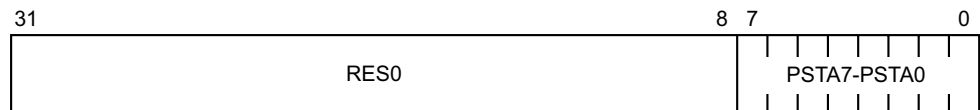

Bits[31:8]

RES0.

PSTA7-PSTA0, bits[7:0]

Each field **PSTAn** represents a sticky status flag for JTAG port *n*, and behaves as R/W1C.

PSTAn is set to **0b1** if all the following are true:

- JTAG port *n* is connected to the JTAG-AP.
- **PSEL.PSELn** is **0b1**.
- JTAG port *n* is disabled.

Once set to **0b1**, **PSTAn** remains set until it is written with the value **0b1**.

As long as **PSTAn** is **0b1**, JTAG port *n* remains disabled.

If JTAG port *n* is not connected to the JTAG-AP, **PSTAn** is RAZ.

Table C3-7 shows the behavior of $PSTA_n$ on reads and writes:

Table C3-7 Read and write behavior of $PSTA_n$

Value	Meaning on reads	Action on writes
0b0	Port has not been disabled, or port is not connected.	No action, write is ignored
0b1	Port has been disabled	Clear $PSTA_n$ to 0b0

Accessing PSTA

$PSTA$ can be accessed from the JTAG-AP register space:

Offset

0xD08

Part D

ROM Tables

Chapter D1

About ROM Tables

The chapter describes ROM Tables. It includes the following sections:

- *ROM Tables Overview* on page D1-290.
- *ROM Table Types* on page D1-291.
- *Component and Peripheral ID Registers for ROM Tables* on page D1-292.
- *The component address* on page D1-293.
- *Location of the ROM Table* on page D1-294.
- *ROM Table hierarchies* on page D1-295.

D1.1 ROM Tables Overview

ROM Tables hold information about debug components.

- If an implementation of the ADI connects to a single debug component, a ROM Table is not required. However, a designer might choose to implement such a system to include a ROM Table, as shown in [Figure A1-6 on page A1-33](#).
- If an implementation of the ADI connects to more than one debug component, the system must include at least one ROM Table.

A ROM Table connects to a bus controlled by a MEM-AP. In other words, the ROM Table is part of the address space of the memory system that is connected to a MEM-AP. More than one ROM Table can be connected to a single bus.

A ROM Table always occupies 4KB of memory.

D1.2 ROM Table Types

The following types of ROM Tables are permitted to be used with ADiv6:

Class 0x1 ROM Tables

In a Class 0x1 ROM Table implementation:

- The Component class field, [CIDR1.CLASS](#), is 0x1, which identifies the component as a Class 0x1 ROM Table.
- The [PIDR4.SIZE](#) field must be 0.
- A ROM Table must occupy a single 4KB block of memory.
- A Class 0x1 ROM Table is a read-only device.

For a detailed description of the Class 0x1 ROM Table entries and registers, see [Chapter D2 Class 0x1 ROM Tables](#).

Class 0x9 ROM Tables

In a Class 0x9 ROM Table implementation:

- The Component class field, [CIDR1.CLASS](#), is 0x9, which identifies the component as a CoreSight Component.
- The [DEVTYPE](#) and [DEVID](#) registers contain information about the ROM Table, as described in [Chapter D3 Class 0x9 ROM Tables](#).
- The [PIDR4.SIZE](#) field must be 0.
- A ROM Table must occupy a single 4KB block of memory.
- Class 0x9 ROM Table entries are 32 or 64 bits wide.

For a detailed description of the Class 0x9 ROM Table entries and registers, see [Chapter D3 Class 0x9 ROM Tables](#).

Note

Class 0x9 ROM Tables can be used alongside Class 0x1 ROM Tables, and both Class 0x9 and Class 0x1 ROM Tables might be present in systems with an ADiv6-compliant interface.

D1.3 Component and Peripheral ID Registers for ROM Tables

Any ROM Table must implement a set of Component and Peripheral ID Registers, that start at offset 0xFD0 in the ROM Table. *Arm® CoreSight™ Architecture Specification* describes these registers. This section only describes particular features of the registers when they relate to a ROM Table.

D1.3.1 Identifying the debug SoC, system, or subsystem

The Unique Component Identifier in a ROM table uniquely identifies the SoC, platform, or subsystem described by the ROM table. For example:

- A cluster of components grouped together with a ROM table hierarchy pointing to all the components is uniquely identified by the outermost ROM Table in the cluster.
- A subsystem of all components connected to a single MEM-AP is uniquely identified by the outermost ROM Table in the subsystem. This ROM Table is usually the first component pointed to by the MEM-AP.
- An SoC, consisting of multiple MEM-APs implementing the ADiv5, is uniquely identified by the collective Unique Component Identifiers from all of the outermost ROM Tables pointed to by each of the MEM-APs.
- An SoC, consisting of multiple MEM-APs implementing the ADiv6, is uniquely identified by the Unique Component Identifiers from the outermost ROM Table providing pointers to each of the MEM-APs. This ROM Table is usually the first component pointed to by the DP.

An SoC, system, or subsystem might be configurable when being built. For example, a cluster of processors might permit the number of processors to be configurable. The ROM Table, which describes such a collection of components, might have the same Unique Component Identifier for all configurations of the system. Although, this is only permitted when components are either included or excluded, and is not permitted to be the same when the location of any component in the address map changes or components significantly change in function. In effect, a ROM Table Unique Component Identifier uniquely identifies a superset configuration of the collection of components. ROM Tables with the same Unique Component Identifier might only describe a subset of this superset.

The DP [TARGETID](#) register also uniquely identifies the SoC or platform, and Arm deprecates use of the top-level ROM Table Peripheral ID registers as a unique identifier by tools.

———— **Note** —————

If SWJ-DP is implemented, it is not required that both the JTAG-DP and SW-DP implement the same DP architecture version, and therefore [TARGETID](#). Tools might be using a DP that does not implement DPv3.

Deprecation of the use of the top-level ROM Table peripheral ID registers by tools does not remove the requirement on implementations to provide a unique identifier in the top-level ROM Table peripheral ID registers. Future releases of this manual might remove this requirement.

D1.4 The component address

Each debug component occupies one or more 4KB blocks of address space. This block of address space is referred to as the Debug Register File for the component. For examples, see [Figure A1-3 on page A1-30](#), and other figures in [Chapter A1](#).

The Address offset field of a ROM Table entry, `ROMENTRY<n>.OFFSET`, points to the start of the 4KB block which contains the Peripheral ID and Component ID registers of component *n*. The base address of this 4KB block is calculated using the following equation:

$$\text{Component_n_Address} = \text{ROM_Base_Address} + (\text{ROMENTRY<n>.OFFSET} \ll 12)$$

In systems where the components and ROM tables exist in an address space which is larger than 32 bits, and the ROM table entry is a 32-bit value, the offset provided in the ROM table entry is sign-extended to the size of the address space, before being added to the `ROM_Base_Address`.

The Component and Peripheral ID Registers for component *n* start at `Component_n_Address + 0xFD0`.

For a component that occupies more than one 4KB block, the size of the component and the base address of the component are IMPLEMENTATION DEFINED, and might be determined by a combination of the values in the Peripheral ID registers and other IMPLEMENTATION DEFINED registers.

———— Note ————

For a component which occupies more than 4KB, the ROM Table entry always points to the 4KB block which contains the Peripheral ID and Component ID registers, and this 4KB might occupy any 4KB block in the Debug Register File of the component.

Previous versions of this specification used the `PIDR4.SIZE` field to define the size and base address of the component. The use of the `PIDR4.SIZE` field is deprecated, and Arm recommends that for all components:

- Debuggers ignore the value of `PIDR4.SIZE`.
- New components set `PIDR4.SIZE` to zero.

Previous versions of this specification required the Peripheral ID and Component ID registers to occupy the highest 4KB block of the Debug Register File. This requirement is removed.

In general, the ROM Table indicates all the valid addresses in the memory map of the connection from the ADI to the system being debugged. For more information about accesses to addresses that are not pointed to by the ROM Table, see [MEMTYPE, Memory Type Register on page D2-306](#).

Arm recommends that the debug component base address is aligned to the largest translation granule supported by any PE that can access the component, which is up to 64KB for an Armv8 or Armv9 PE.

For more information about the Component and Peripheral ID Registers, see *Arm® CoreSight™ Architecture Specification*.

D1.5 Location of the ROM Table

This section describes how to provide a pointer to the top-level ROM Table.

While entries in a ROM Table are always relative addresses, the top-level pointer to a ROM Table always takes the form of an absolute address.

From an AP or a DP

Each MEM-AP contains a **BASE** register that indicates one of the following:

- The base address of a ROM Table.
- The address of a debug component, which must be the only debug component that is accessible from that AP. The memory system that is accessed by this MEM-AP does not contain a ROM Table.
- No debug components are accessible from this AP, which is indicated by **BASE.P** having the value `0b0`.

Each DP contains the **BASEPTR0-BASEPTR1** registers that indicate one of the following:

- The base address of a ROM Table.
- The address of a debug component, which is the only debug component that is directly accessible from this DP. The debug component might be an AP that provides indirect access to more debug components.
- No debug components are accessible from this DP, which is indicated by **BASEPTR0.VALID** having the value `0b0`.

From processor cores

The operating system or debug monitor must be aware of the memory map of the system to find the ROM Table and debug components.

D1.6 ROM Table hierarchies

Normally, each ROM Table entry, ROMENTRY<n>, points to the memory space of a debug component. The Component and Peripheral ID Registers for that component start at offset 0xFD0 in a 4KB section of the memory space of the component. The Component class field CIDR1.CLASS, bits [7:4] of the Component ID1 Register, identifies the type of the component. This field is described in CIDR0-CIDR3 in *Arm® CoreSight™ Architecture Specification*.

ROMENTRY<n> can point to another ROM Table, which is referred to as a lower-level ROM Table.

A ROM Table can include more than one entry that points to lower-level ROM Tables, and a hierarchy of ROM Tables can exist. All ROM Tables within that hierarchy must be scanned to discover all the debug components in the system.

A system with an interface that is compliant with ADIV6 can contain both Class 0x1 and Class 0x9 ROM Tables in a single implementation.

When identifying Class 0x1 ROM Tables, DEVARCH and DEVTYPE are treated as having a value of 0.

If more than the maximum number of ROM Table entries are required, the ROM Table must be expanded by creating a ROM Table hierarchy which contains as many ROM Table entries as necessary.

The MEM-AP BASE register must point to the top-level ROM Table in the hierarchy.

Figure D1-1 shows an example of a ROM Table hierarchy.

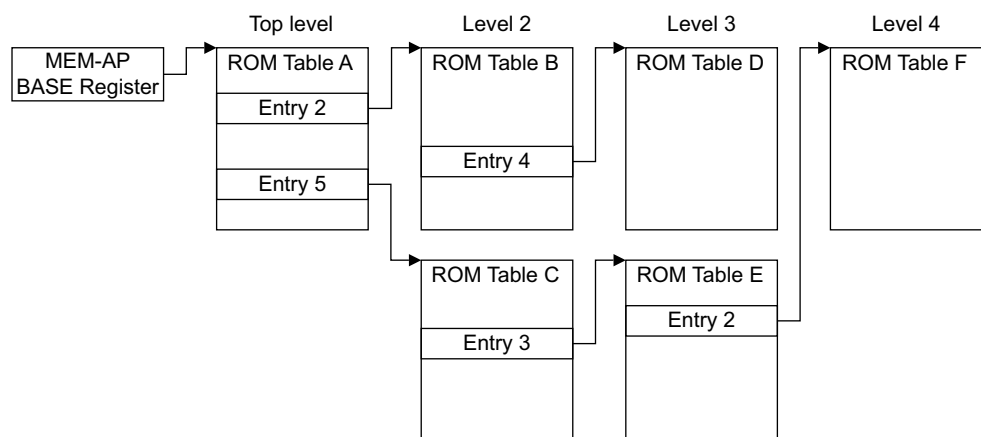

Figure D1-1 ROM Table hierarchy example

A hierarchy of ROM Tables might increase the total number of ROM Table entries in the system.

A hierarchy might be implemented for some other reason, for example to reflect the logical organization of the debug components of the system. There might be only a few entries in each ROM Table within a hierarchy.

D1.6.1 Peripheral ID Registers in lower-level ROM Tables

The Peripheral ID value that is obtained from the Peripheral ID Registers of any ROM Table that is not a top-level ROM Table is used to identify the subsystem described by the ROM Table. It is not used to identify the SoC or platform.

D1.6.2 Component Revision Numbers

When a component is changed, the revision number that is contained in the Unique Component Identifier of that component must be changed to ensure that debug tools can differentiate the versions of the component, which usually involves changing one or more of PIDR2.REVISION and PIDR3.REVAND. For details about the Unique Component Identifier, see the *Arm® CoreSight™ Architecture Specification v3.0*.

In systems that are designed as multiple subsystems of components, each subsystem has a ROM table that indicates the locations of the components in the subsystem. When changing the revision of a component in a subsystem:

- The revision of the subsystem that the component is part of may or may not change.
- The revision number of the ROM table describing that subsystem may or may not change.

As a result, debug tools must inspect the revision of each component within a subsystem to uniquely identify the revision of those components and must not rely on the revision of the ROM table to uniquely identify the revision of all the components within the subsystem.

For example, if the revision number of a trace macrocell that is part of a subsystem with a ROM table that describes the layout of the subsystem changes, the revision of the ROM table might not change, and multiple instances of the subsystem with the same revision number could exist in the ROM table, even though the components making up the subsystems have different revision numbers for each subsystem.

D1.6.3 Prohibited ROM Table references

Every debug component within a system must appear only once in the ROM Table, or ROM Table hierarchy, that is visible to an external debugger. Figure D1-2 shows a prohibited case, where entries in ROM Tables B and C both point to ROM Table D.

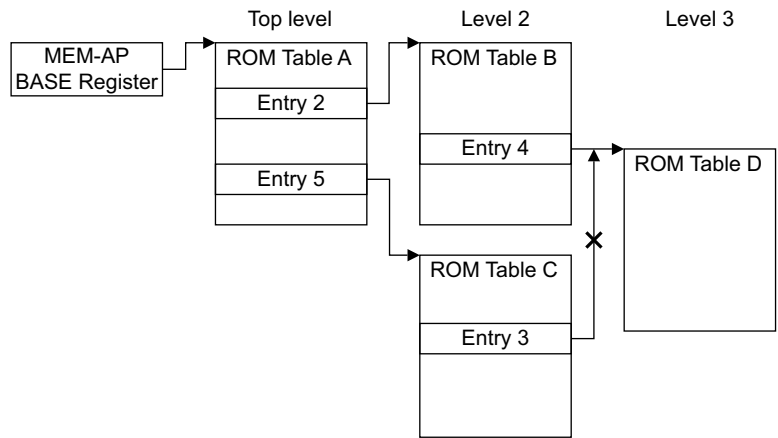

Figure D1-2 Prohibited duplicate ROM Table reference from ROM Table

Figure D1-3 shows a similar prohibited case, where entries in ROM Table A and MEM-AP 2 both point to ROM Table B.

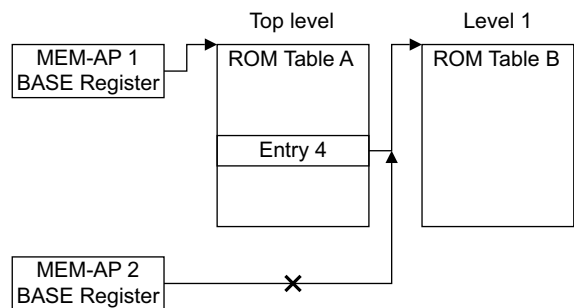

Figure D1-3 Prohibited duplicate ROM Table reference from MEM-AP

In addition, circular ROM Table references are prohibited. A ROM Table entry must not point to a ROM Table that directly or indirectly points to itself. In particular, ROM Table entries must not point back to the top-level ROM Table, as is shown in Figure D1-4 on page D1-297, where both ROM Table B and ROM Table C have prohibited links back to ROM Table A.

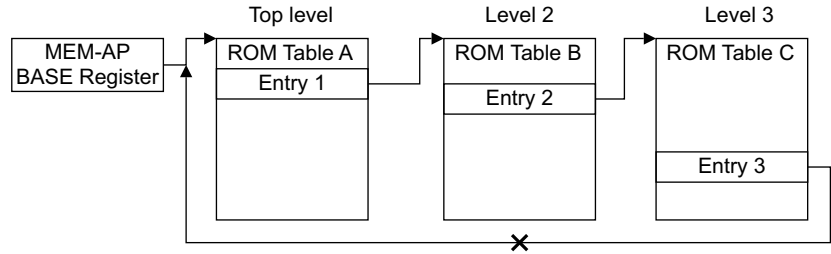

Figure D1-4 Prohibited circular ROM Table references

There is no requirement that components in separate ROM Table hierarchies must be in separate systems, which includes multiple APs in a single ADI implementation, and multiple ADI implementations. For example, if MEM-AP 1 in ADI implementation 1 points to a hierarchy of ROM Tables which includes a pointer to trace macrocell A, and MEM-AP 2 in ADI implementation 2 points to a hierarchy of ROM Tables which includes a pointer to trace sink B, then trace from trace macrocell A can be collected by trace sink B, as shown in Figure D1-5.

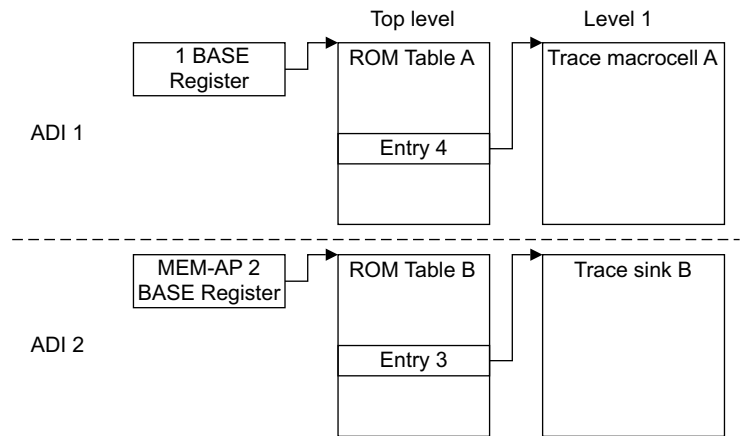

Figure D1-5 Components in separate ROM Table hierarchies

Chapter D2

Class 0x1 ROM Tables

The chapter describes Class 0x1 ROM Tables. It includes the following sections:

- *About Class 0x1 ROM Tables* on page D2-300.
- *Class 0x1 ROM Table summary* on page D2-301.
- *Use of power domain IDs* on page D2-303.
- *Register Descriptions* on page D2-305.

D2.1 About Class 0x1 ROM Tables

In a Class 0x1 ROM Table implementation:

- The Component class field, [CIDR1.CLASS](#), is 0x1, which identifies the component as a Class 0x1 ROM Table.
- The [PIDR4.SIZE](#) field must be 0, because a ROM Table must occupy a single 4KB block of memory.

Class 0x1 ROM Tables can be used alongside Class 0x9 ROM Tables, and both Class 0x1 and Class 0x9 ROM Tables might be present in systems with an ADIV6-compliant interface.

See also:

- For general information about ROM Tables, see [Chapter D1 About ROM Tables](#).
- For information about the Component and Peripheral ID Registers, see *Arm® CoreSight™ Architecture Specification*. The class configuration is described in the field description of the [CIDR1.CLASS](#) field, in section [CIDR0-CIDR3](#) in *Arm® CoreSight™ Architecture Specification*.
- For information about Class 0x9 ROM Tables, see [Chapter D3 Class 0x9 ROM Tables](#).

D2.2 Class 0x1 ROM Table summary

This section summarizes the characteristics of Class 0x1 ROM Tables.

D2.2.1 Class 0x1 ROM Table Layout

A Class 0x1 ROM Table:

- Occupies a single 4KB block of memory, and starts at offset 0x000 in this block.
- Has a series of entries, each of which is a register.
- Has a final entry, which is one of the following:
 - A marker with the value 0x00000000, which signals the end of the ROM Table.
 - A regular entry at offset 0xEFC. A ROM Table entry at this offset is always the final entry, even if it does not have the value 0x00000000.
- Almost always has an unused area between the entry that marks the end of the ROM Table entries and the start of the reserved area at offset 0xF00. This unused area is reserved, RES0. If a ROM Table contains 960 entries, there is no unused area.

Table D2-1 shows the Class 0x1 ROM Table registers, in order of their address offset in the 4KB block where the programmers' model resides. For detailed descriptions of each register, see [Register Descriptions on page D2-305](#).

Table D2-1 ROM Table register summary

Offset	Type	Name	Description
ROM Entries, including any unused area			
0x000 to (N-1)×4	RO	ROMENTRY<n>	Up to 960 ROM Table entries ^a . The end of the area that contains ROM Table entries is IMPLEMENTATION DEFINED, and depends on the number of ROM Table entries, which is denoted N.
N×4	RO	ROMENTRY<n> with value 0x00000000	Marker that indicates the final entry in a ROM Table with fewer than 960 entries. The offset of this entry depends on the number of ROM Table entries, which is denoted N. See also <i>ROM Table entries that are marked not present</i> on page D2-302.
(N+1)×4 to 0xEFC	-	Unused area of the ROM Table.	RES0. The offset depends on the number of ROM Table entries, which is denoted N. This area is not present if N is 960.
Reserved area			
0xF00 - 0xFC8	-	Reserved area of the ROM Table.	RES0.
MEMTYPE and ID registers			
0xFCC	RO	MEMTYPE	Memory Type Register.
0xFD0 - 0xFDC	RO	PIDR4-PIDR7	Peripheral Identification Registers.
0xFE0 - 0xFEC	RO	PIDR0-CIDR3	
0xFF0 - 0xFFC	RO	CIDR0-CIDR3	Component Identification Registers.

a. An implementation is unlikely to require more than the maximum number of entries in a ROM Table. However, [ROM Table hierarchies on page D1-295](#) describes how larger ROM Tables can be constructed.

D2.2.2 ROM Table entries that are marked *not present*

The descriptions of the debug components are stored in sequential locations in the ROM Table, starting at the ROM Table base address. However, a ROM Table entry can be marked not present by setting the PRESENT field of the entry to a value that indicates that the entry is not present.

When scanning the ROM Table, an entry that is marked as not present must be skipped. Unless the entry has the value 0x00000000, however, it must not be assumed that an entry that is marked not present represents the end of the ROM Table. For example, a ROM Table might be generated using static configuration tie-offs that indicate the presence or absence of particular devices, giving not present entries in the ROM Table.

D2.3 Use of power domain IDs

If the following conditions are met, a Class 0x1 ROM Table entry, `ROMENTRY<n>`, has a valid power domain ID m :

- `ROMENTRY<n>.PRESENT` is 0b1, indicating that the ROM Table entry is present.
- `ROMENTRY<n>.POWERIDVALID` is 0b1, indicating that the power ID is valid.
- `ROMENTRY<n>.POWERID` is m , the power domain ID.

If any of the `ROMENTRY<n>` has a valid power domain ID, the ROM Table must include a valid entry that points to a power requester that enables a debugger to request power to the power domains that are specified in the ROM Table. The power requester must comply with the following rules:

- The power requester must not have a valid power domain ID.
- The power requester must be in the same power domain as the ROM Table.

For any component with a valid power domain ID, Arm recommends that, before accessing any register in a component, the debugger first accesses the power requester to request that power is applied to the component. Otherwise the component might not be powered, or it might be powered down at any time.

D2.3.1 Power domain entries

The power domain ID is specific to components identified by the Class 0x1 ROM Table, which enables hierarchies of power domains to be constructed with each level enabling access to a level below.

Figure D2-1 shows an example Class 0x1 ROM Table that indicates the locations of three components.

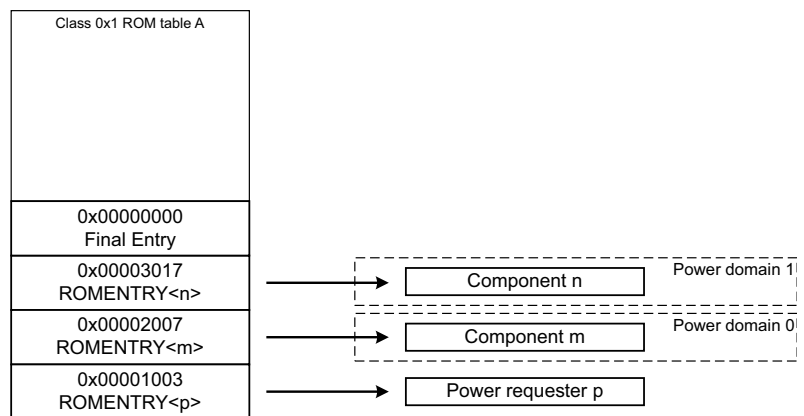

Figure D2-1 Single Class 0x1 ROM Table with power domain IDs

In Figure D2-1, the first component, p , has no valid power domain ID and is the power requester. The other two components, m and n , have power domain IDs of 0 and 1 respectively. The debugger requests power for these components, by using the power requester p .

Figure D2-2 on page D2-304 shows an example system with nested power domains.

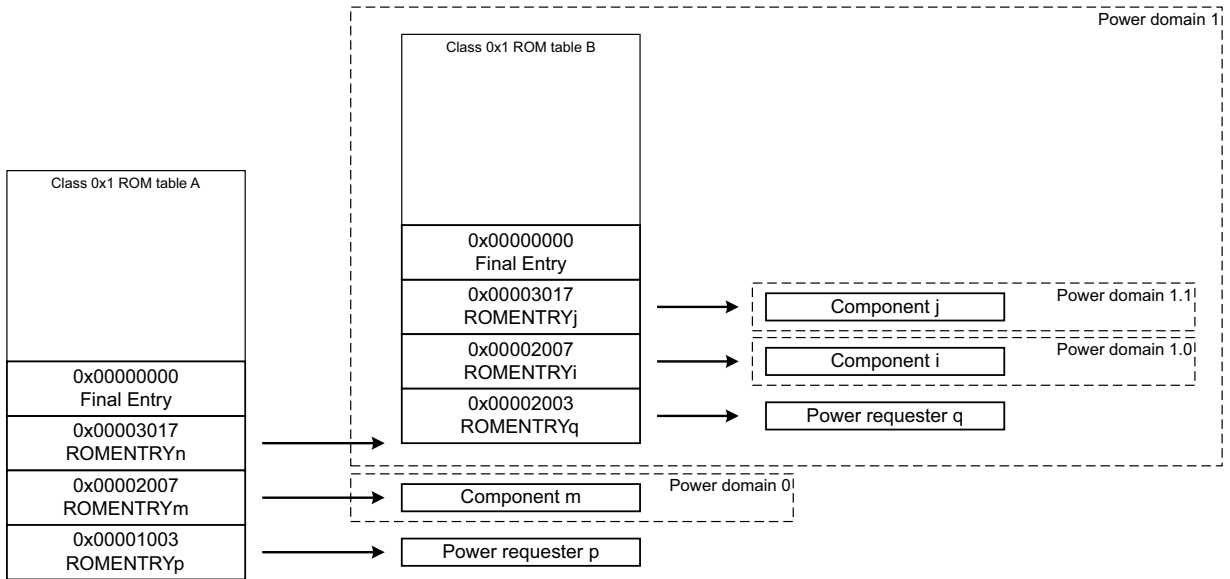

Figure D2-2 Multiple ROM Tables with nested power domain IDs

In [Figure D2-2](#), ROM Table A is the top-level ROM Table and indicates the presence of:

- Power requester p , which must be in the same power domain as the ROM.
- Component m , which is in power domain 0.
- ROM Table B, which is in power domain 1.

ROM Table B indicates the presence of power requester q and components i and j , so power for components i and j is requested through power requester q . Because power requester q is in power domain 1, the power domains it controls are subdomains of power domain 1, and are labeled 1.0 and 1.1.

The power domain IDs indicated by ROM Table B are different from the power domain IDs indicated by ROM Table A and are nested within power domain 1.

D2.3.2 Algorithm to discover power domain IDs

Inspect each Class 0x1 ROM Table in the system, starting at the top-level ROM Table. For each valid Class 0x1 ROM Table entry `ROMENTRY<n>`:

1. If `ROMENTRY<n>.POWERIDVALID` is `0b1`, the power domain ID information is present. To request power for this entry, use the `ROMENTRY<n>.POWERID` field, bits[8:4], to program the power Requester.
2. If `ROMENTRY<n>.POWERIDVALID` is `0b0`, no power domain ID information is present.
 - Inspect the component and determine if it is a power Requester. Power Requester components have no power domain ID. Make a note of whether a power Requester is detected.
 - If the component is not a power Requester, the absence of a power domain ID value indicates that it is powered, and no power requests are required to power this component.

———— **Note** ————

If no power Requester is indicated in this ROM Table, all entries in this ROM Table must not have valid power domain IDs.

If there are Class 0x9 ROM Tables in the system, use the algorithm that is described in [Chapter D3 Class 0x9 ROM Tables](#), section [Algorithm to discover power domain IDs](#) to discover power domains in them.

D2.4 Register Descriptions

This section provides detailed descriptions of the registers in a Class 0x1 ROM Table, in alphabetical order.

D2.4.1 CIDR0-CIDR3, Component Identification Registers

This section describes the bit assignments for ROM Table components. For a full description of the CIDR, see CIDR0-CIDR3 in *Arm® CoreSight™ Architecture Specification*.

The [CIDR0-CIDR3](#) characteristics are:

Purpose

Provide information to identify a CoreSight component.

Usage constraints

[CIDR0-CIDR3](#) are accessible as follows:

Default

RO

Configurations

Included in all implementations.

Attributes

Four 32-bit management registers.

Field Descriptions

The [CIDR0-CIDR3](#) bit assignments are:

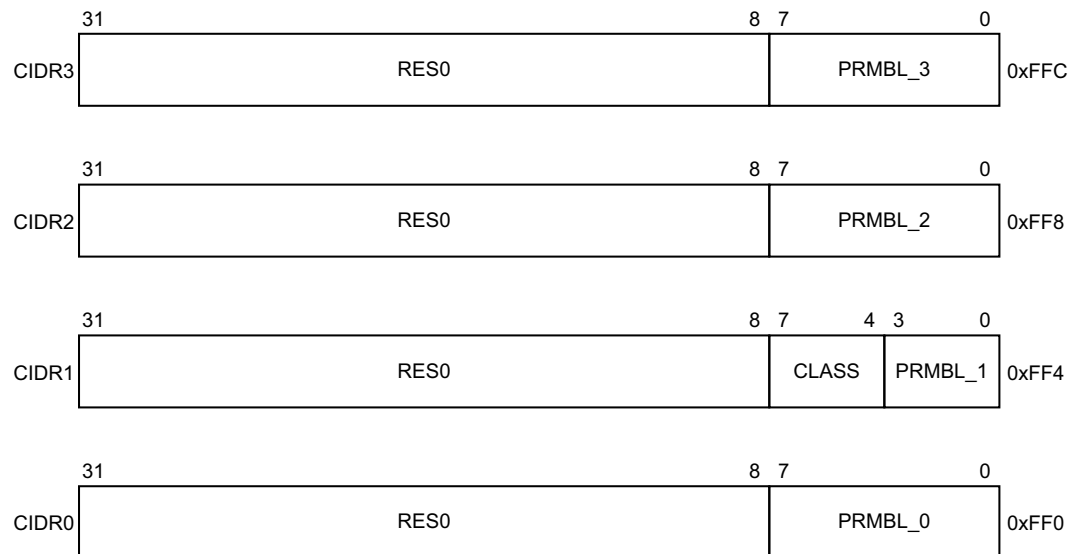

CIDR3 bits[31:8]

RES0.

PRMBL_3, CIDR3 bits[7:0]

0xB1.

CIDR2 bits[31:8]
RES0.

PRMBL_2, CIDR2 bits[7:0]
0x05.

CIDR1 bits[31:8]
RES0.

CLASS, CIDR1 bits[7:4]
0x1.

PRMBL_1, CIDR1 bits[3:0]
0x0.

CIDR0 bits[31:8]
RES0.

PRMBL_0, CIDR0 bits[7:0]
0x00.

Accessing CIDR0-CIDR3

[CIDR0-CIDR3](#) can be accessed at the following address:

Component	Offset			
	CIDR0	CIDR1	CIDR2	CIDR3
ROM Table	0xFF0	0xFF4	0xFF8	0xFFC

D2.4.2 MEMTYPE, Memory Type Register

The [MEMTYPE](#) characteristics are:

Purpose

Identifies the type of memory present on the bus that connects to the ROM Table. In particular, it identifies whether system memory is connected to the bus.

Usage constraints

[MEMTYPE](#) is accessible as follows:

Default
R0

Configurations

Included in all implementations.

Attributes

A 32-bit register.

Field Descriptions

The **MEMTYPE** bit assignments are:

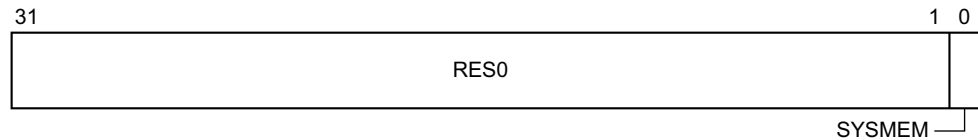

Bits [31:1]

Reserved, RES0.

SYSTEMEM, bit [0]

System memory present. Indicates whether system memory is present on the bus that connects to the ROM Table. The possible values are:

- 0b0 System memory not present on bus. This value indicates that the bus is a dedicated debug bus.
- 0b1 System memory is also present on this bus.

Use of SYSTEMEM by software is deprecated, and debuggers should ignore the value of this field.

Setting SYSTEMEM to 0b1 is deprecated, and SYSTEMEM is permitted to have the value 0b0 in systems where there are other valid addresses in the memory system.

MEMTYPE.SYSTEMEM indicates the memory accesses that can be performed:

When SYSTEMEM is 0b0

The ROM Table indicates all the valid addresses in the memory system, and the result of accessing any other address is UNPREDICTABLE. For more information, see [The component address on page D1-293](#).

When SYSTEMEM is 0b1

There might be other valid addresses in the memory system. The result of accessing these addresses is IMPLEMENTATION DEFINED, and:

- The ADI specification does not include any mechanism that can be used to discover what addresses it can access, other than the addresses that are listed in the ROM Table.
- If accesses are performed to addresses that are not in the ROM Table, there can be side effects on the system.

Accessing MEMTYPE

MEMTYPE can be accessed at the following address:

Component	Offset
ROM Table	0xFCC

D2.4.3 PIDR0-PIDR7, Peripheral Identification Register

This section describes the bit assignments for ROM Table components. For a full description of the PIDR, see PIDR0-PIDR7 in *Arm® CoreSight™ Architecture Specification*.

The **PIDR0-PIDR7** characteristics are:

Purpose

Provide information to identify a CoreSight component.

Usage constraints

PIDR0-PIDR7 are accessible as follows:

Default

RO

Configurations

Included in all implementations.

Attributes

Eight 32-bit management registers.

Field Descriptions

The PIDR0-PIDR7 bit assignments are:

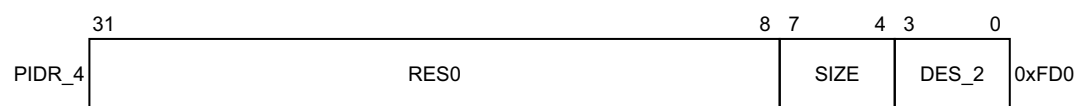
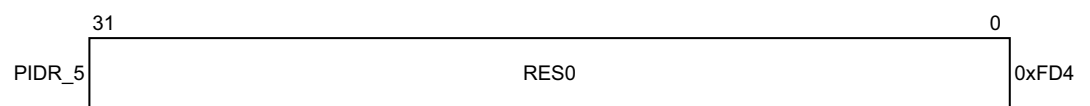
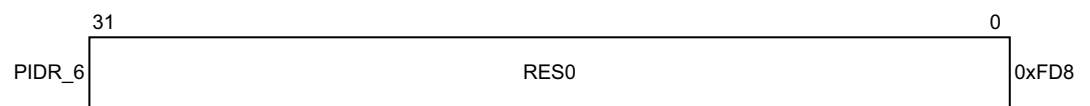
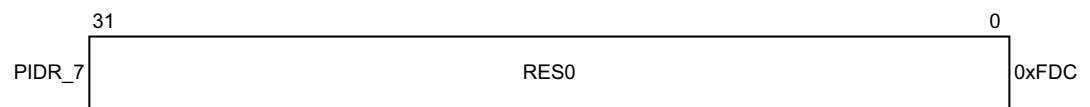
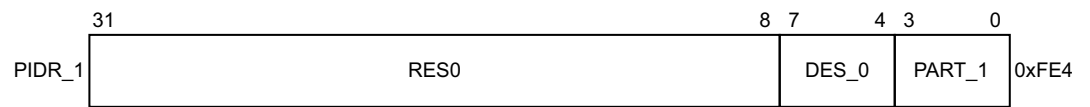
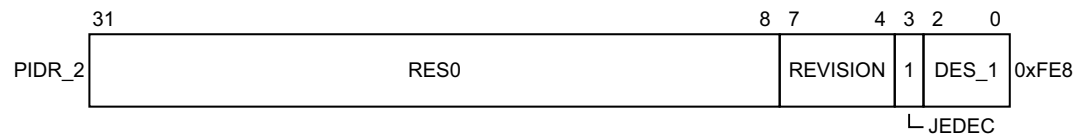
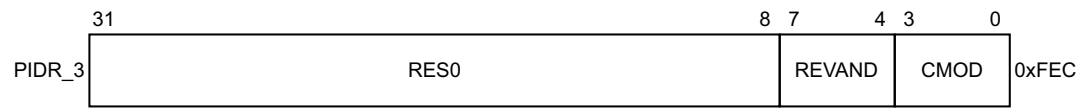

PIDR3 bits[31:8]

RES0.

REVAND, PIDR3 bits[7:4]

See register descriptions in PIDR0-PIDR7 in *Arm® CoreSight™ Architecture Specification*.

CMOD, PIDR3 bits[3:0]

See register descriptions in PIDR0-PIDR7 in *Arm® CoreSight™ Architecture Specification...*

PIDR2 bits[31:8]

RES0.

REVISION, PIDR2 bits[7:4]

See register descriptions in PIDR0-PIDR7 in *Arm® CoreSight™ Architecture Specification*.

JEDEC, PIDR2 bits[3]

0b1

DES_1, PIDR2 bits[2:0]

See register descriptions in PIDR0-PIDR7 in *Arm® CoreSight™ Architecture Specification*.

PIDR1 bits[31:8]

RES0.

DES_0, PIDR1 bits[7:4]

See register descriptions in PIDR0-PIDR7 in *Arm® CoreSight™ Architecture Specification*.

PART_1, PIDR1 bits[3:0]

See register descriptions in PIDR0-PIDR7 in *Arm® CoreSight™ Architecture Specification*.

PIDR0 bits[31:8]

RES0.

PART_0, PIDR0 bits[7:0]

See register descriptions in PIDR0-PIDR7 in *Arm® CoreSight™ Architecture Specification*.

PIDR7 bits[31:0]

RES0.

PIDR6 bits[31:0]

RES0.

PIDR5 bits[31:0]

RES0.

PIDR4 bits[31:8]

RES0.

SIZE, PIDR4 bits[7:4]

0x0 A ROM Table occupies a single 4KB block of memory.

DES_2, PIDR4 bits[3:0]

See register descriptions in PIDR0-PIDR7 in *Arm® CoreSight™ Architecture Specification*.

Accessing PIDR0-PIDR7

[PIDR0-PIDR7](#) can be accessed at the following address:

Component	Offset							
	PIDR0	PIDR1	PIDR2	PIDR3	PIDR4	PIDR5	PIDR6	PIDR7
ROM Table	0xFE0	0xFE4	0xFE8	0xFEC	0xFD0	0xFD4	0xFD8	0xFDC

D2.4.4 ROMENTRY<n>, Class 0x1 ROM Table entries

A Class 0x1 ROM Table contains up to 960 ROM Table entries. Each entry that is present, [ROMENTRY<n>](#), describes a single component, component *n*.

The series of ROM Table entries start at the base address of the ROM Table. The value of a [ROMENTRY<n>](#) depends on the subsystem that is implemented.

The [ROMENTRY<n>](#) characteristics are:

Purpose

Describes a single debug component within the system.

Usage constraints

[ROMENTRY<n>](#) registers are accessible as follows:

Default
RO

Configurations

Included in all implementations. For details, see [The component address on page D1-293](#).

Attributes

Up to 512 32-bit registers.

Field Descriptions

The [ROMENTRY<n>](#) bit assignments are:

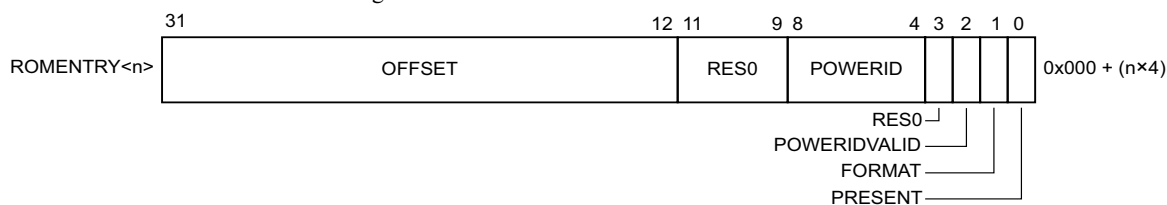

OFFSET, bits[31:12]

The address of the component, relative to the base address of this ROM Table.

Negative values are permitted, using two's complement.

Note

If **FORMAT** and **PRESENT** both have a value that is not equal to $0b0$, **OFFSET** must not be zero, because a zero address offset points back to the ROM Table that contains this [ROMENTRY<n>](#).

For more information, see [The component address on page D1-293](#).

Bits[11:9]

RES0.

POWERID, bits[8:4]

The Power domain ID of the component. This field:

- Supports up to 32 Power domains using values 0x00 to 0x1F.
- Is only valid if the POWERIDVALID field, which consists of bit[2] of the same ROM Table entry, is 0b1, otherwise this field must be RAZ.

For more information about Power domains, see the *Arm® CoreSight™ Architecture Specification*.

Bit[3]

RES0.

POWERIDVALID, bit[2]

Indicates if the Power domain ID field contains a Power domain ID:

- 0b0 A Power domain ID is not provided.
- 0b1 The POWERID field, which consists of bits[8:4] of the same ROM Table entry, provides a Power domain ID.

FORMAT, bit[1]

Indicates the format of the ROM Table. This field has the following value:

- RAO 32-bit ROM Table format.

PRESENT, bit[0]

Indicates whether an entry is present at this location in the ROM Table. This field can have one of the following values:

- 0b0 The ROM entry is not present.
- 0b1 The ROM entry is present.

For more information, see *ROM Table entries that are marked not present on page D2-302*.

Accessing the ROMENTRY<n>

The [ROMENTRY<n>](#) for component *n* can be accessed at the following address:

Component	Offset
ROM Table	0x000 + <i>n</i> ×4

Chapter D3

Class 0x9 ROM Tables

The chapter describes Class 0x9 ROM Tables. It includes the following sections:

- *About Class 0x9 ROM Tables* on page D3-314.
- *Class 0x9 ROM Table summary* on page D3-315.
- *Use of power domain IDs* on page D3-319
- *Reset control* on page D3-325
- *Register descriptions* on page D3-328.

D3.1 About Class 0x9 ROM Tables

In a Class 0x9 ROM Table implementation:

- The Component class field, CIDR1.CLASS, is 0x9, identifying the component as a CoreSight component.
- The Device Architecture Register, [DEVARCH](#), identifies the component as a Class 0x9 ROM Table.

Class 0x9 ROM Tables can be used alongside Class 0x1 ROM Tables, and both Class 0x9 and Class 0x1 ROM Tables might be present in systems with an ADIV6-compliant interface.

See also:

- For general information about ROM Tables, see [Chapter D1 About ROM Tables](#).
- For information about the Component and Peripheral ID Registers, see *Arm® CoreSight™ Architecture Specification*. The class configuration is described in the field description of the CIDR1.CLASS field, in section CIDR0-CIDR3 in *Arm® CoreSight™ Architecture Specification*.
- For information about Class 0x1 ROM Tables, see [Chapter D2 Class 0x1 ROM Tables](#).

The COM Port function can be included in a Class 0x9 ROM table. For more information, see the *Advanced Communications Channel Architecture Specification*. One reason to include the COM Port function in a ROM table is to provide means to enable debug access to the components indicated in the ROM table.

D3.2 Class 0x9 ROM Table summary

This section summarizes the characteristics of Class 0x9 ROM Tables.

D3.2.1 Class 0x9 ROM Table Layout

Table D3-1 shows the Class 0x9 ROM Table registers, in order of their address offset in the 4KB block where the programmers' model resides. For detailed descriptions of each register, see [Register descriptions on page D3-328](#).

A Class 0x9 ROM Table:

- Occupies a single 4KB block of memory, and starts at offset 0x000 in this block.
- Has a series of entries, each of which is a register.
- Has a final entry, which is one of the following:
 - A marker that signals the end of the ROM Table, which has an entry that is all zeros.
 - A regular entry at offset 0x7FC. A ROM Table entry at this offset is always the final entry, even if its PRESENT field does not have the value 0b00.
- Almost always has an unused area between the final entry of the ROM Table and the start of the reserved area at offset 0x800. This unused area is RES0. If a ROM Table contains the maximum number of entries, there is no unused area.

Table D3-1 ROM Table register summary

Offset	Type	Name	Description
ROM Entries, including any unused area			The number of ROM entries is denoted N . The number of bytes making up a ROM entry, w , and the maximum number of ROM entries, N_{\max} , depend on the configuration of the DEVID register: If DEVID.FORMAT == 0x0, $w = 4$ and $N_{\max} = 512$. If DEVID.FORMAT == 0x1, $w = 8$ and $N_{\max} = 256$.
0x000 to $(N-1) \times w$	RO	ROMENTRY<n>	Up to N ROM entries ^a . The end of the area that contains ROM entries is IMPLEMENTATION DEFINED, and depends on N .
$N \times w$	RO	ROMENTRY<n> with all bits having a value of 0b0.	Marker that indicates the final entry in a ROM Table with fewer than N entries. The offset of this entry depends on N . See also ROM Table entries that are marked not present on page D3-318 .
$(N+1) \times w$ to 0x7FC	-	Unused area of the ROM Table.	RES0. The offset depends on N . This area is not present if N is equal to the maximum number of ROM entries, N_{\max} . See also ROM Table entries that are marked not present on page D3-318 .
Reserved area			
0x800 - 0x9FC	-	Reserved.	RES0.
Power and reset registers			
0xA00 - 0xA7C	RW	DBGPCR<n>	Debug Power Control Registers.
0xA80 - 0xAFC	RW	DBGPSR<n>	Debug Power Status Registers.
0xB00 - 0xB7C	RW	SYSPCR<n>	System Power Control Registers.

Table D3-1 ROM Table register summary (continued)

Offset	Type	Name	Description
0xB80 - 0xBFC	RW	SYSPSR<n>	System Power Status Registers.
0xC00	RO	PRIDR0	Power Request Identification Register 0.
0xC04 - 0xC0C	-	-	RES0.
0xC10	RW	DBGRRSTR	Debug Reset Request Register.
0xC14	RO	DBGRRSTAR	Debug Reset Acknowledge Register.
0xC18	RW	SYSRRSTR	System Reset Request Register.
0xC1C	RO	SYSRRSTAR	System Reset Acknowledge Register.
0xC20 - 0xCFC	-	-	RES0.
COM port			
0xD00 - 0xD7C	-	-	COM Port programmers' model. For more information, see the <i>Advanced Communications Channel Architecture Specification</i> .
Reserved area			
0xD80 - 0xEFC	-	-	RES0.
CoreSight management registers			
0xF00	RW	ITCTRL	Integration Mode Control Register.
0xF04 - 0xF9C	-	-	RES0.
0xFA0	RW	CLAIMSET	Claim Tag Registers.
0xFA4	RW	CLAIMCLR	
0xFA8	RO	DEVAFF0	Device Affinity Registers.
0xFAC	RO	DEVAFF1	
0xFB0	WO	LAR	Lock Access and Lock Status Registers.
0xFB4	RO	LSR	
0xFB8	RO	AUTHSTATUS	Authentication Status Register.
0xFBC	RO	DEVARCH	Device Architecture Register.
0xFC0	RO	DEVID2	Device ID Registers.
0xFC4	RO	DEVID1	
0xFC8	RO	DEVID	Device ID Register.
0xFCC	RO	DEVTYPE	Device Type Register.
0xFD0 - 0xFDC	RO	PIDR4-PIDR7	Peripheral Identification Registers.
0xFE0 - 0xFEC	RO	PIDR0-PIDR3	
0xFF0 - 0xFFC	RO	CIDR0-CIDR3	Component Identification Registers.

- a. An implementation is unlikely to require more than the maximum number of entries in a ROM Table. However, [ROM Table hierarchies on page D1-295](#) describes how larger ROM Tables can be constructed.

D3.2.2 ROM Table entries that are marked *not present*

The descriptions of the debug components are stored in sequential locations in the ROM Table, starting at the ROM Table base address. However, a ROM Table entry can be marked not present by setting the PRESENT field of the entry to a value that indicates that the entry is not present:

- If `ROMENTRY<n>.PRESENT` has the value `0b10`, it is not present and must be skipped. Do not assume that the entry represents the end of the ROM Table when scanning the ROM Table. For example, a ROM Table might be generated using static configuration tie-offs that indicate the presence or absence of particular devices, giving not present entries in the ROM Table.
- If `ROMENTRY<n>.PRESENT` has the value `0b00`, it is not present and indicates the end of the ROM Table.

D3.3 Use of power domain IDs

If the following conditions are met, a Class 0x9 ROM Table entry, `ROMENTRY<n>`, has a valid power domain ID m :

- `ROMENTRY<n>.PRESENT` is `0b11`, indicating that the ROM Table entry is present.
- `ROMENTRY<n>.POWERIDVALID` is `0b1`, indicating that the power ID is valid.
- `ROMENTRY<n>.POWERID` is m , the power domain ID.

The mechanism to power up power domain m can be one of the following:

- If `DBGPCR<m>.PRESENT` reads as `0b1`, the power request mechanism for `DBGPCR<m>.PR` is implemented, and can be used to request power for power domain m , as described in the field descriptions for the `DBGPCR<n>` register.
- If `DBGPCR<m>.PRESENT` reads as `0b0`, the power request mechanism for power domain m is IMPLEMENTATION DEFINED.

Arm recommends that debug tools do not attempt accesses to any component with a valid power domain ID without first powering up the component.

D3.3.1 Power domain entries

The power domain ID is specific to components identified by the Class 0x9 ROM Table, which enables hierarchies of power domains to be constructed with each level enabling access to a level below.

Figure D3-1 shows an example Class 0x9 ROM Table that indicates the locations of two components, m and n . Components m and n are in debug power domain 0 and 1, respectively. The debugger requests power for these power domains through the power and reset registers in the programmers' model of ROM Table A.

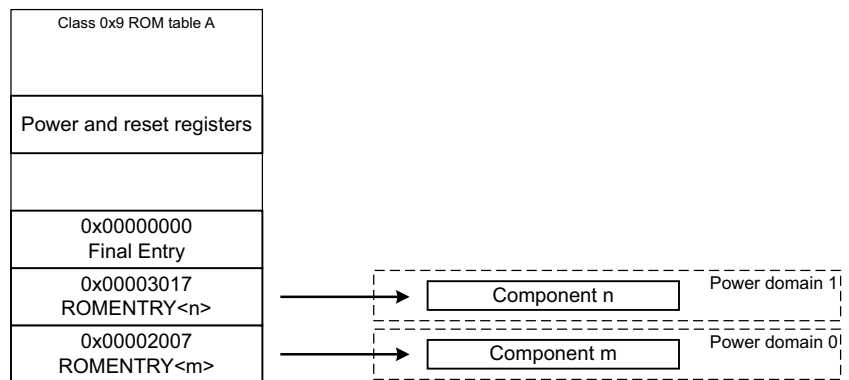

Figure D3-1 Single ROM Table with power domain IDs

Figure D3-2 shows an example system with nested power domains.

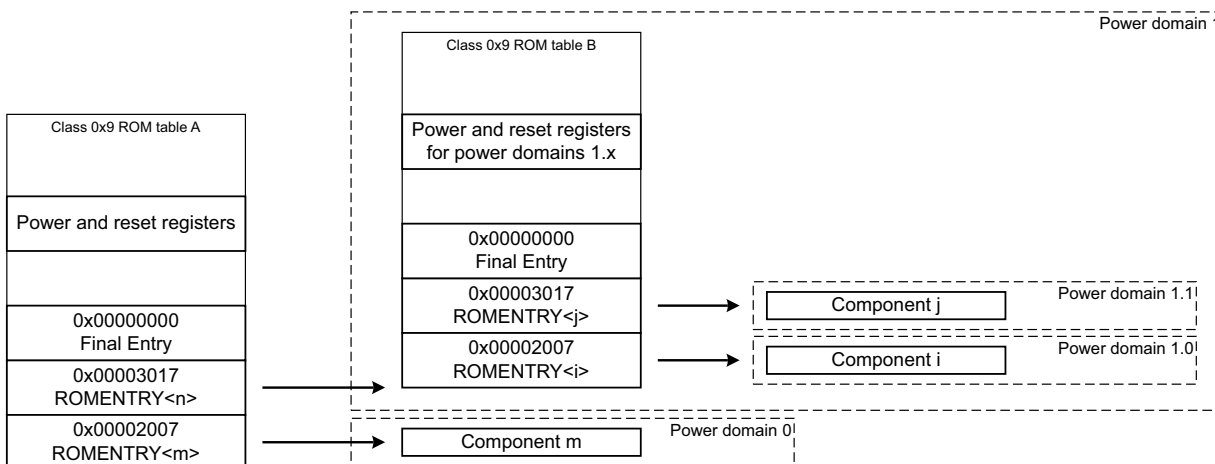

Figure D3-2 Multiple ROM Tables with nested power domain IDs

In Figure D3-2, ROM Table A is the top-level ROM Table and indicates the presence of:

- Component *m*, which is in debug power domain ID 0.
- Component *n*, which is a Class 0x9 ROM Table, ROM Table B, in debug power domain 1.

ROM Table B indicates the presence of components *i* and *j*, and power for these components is requested through the power and reset registers in the programmers' model of ROM Table B. Because ROM Table B is in power domain 1, these power domains are subdomains of power domain 1, and are labeled 1.0 and 1.1.

The power domain IDs indicated by ROM Table B are different from the power domain IDs indicated by ROM Table A and are nested within power domain 1.

D3.3.2 Algorithm to discover power domain IDs

Inspect each Class 0x9 ROM Table in the system, starting at the top-level ROM Table. For each valid Class 0x9 ROM Table entry `ROMENTRY<n>`:

1. If `ROMENTRY<n>.POWERIDVALID` is `0b1`, the power domain ID information is present. To request power for this entry, use the `DBGPCR<m>` register in the programmers' model of the ROM Table, using the value of *m* that is described in `ROMENTRY<n>.POWERID`.
2. If `ROMENTRY<n>.POWERIDVALID` is `0b0`, no power domain ID information is present, so the component is powered.

If there are Class 0x1 ROM Tables in the system, use the algorithm that is described in Chapter D2 *Class 0x1 ROM Tables*, section *Algorithm to discover power domain IDs* to discover power domains in them.

D3.3.3 Debug power requests

If access to a component is needed and the ROM entry for that component has a valid power domain ID, the debugger must request power to that component before attempting to access it.

The process for issuing a power request for a debug component is shown in Figure D3-3.

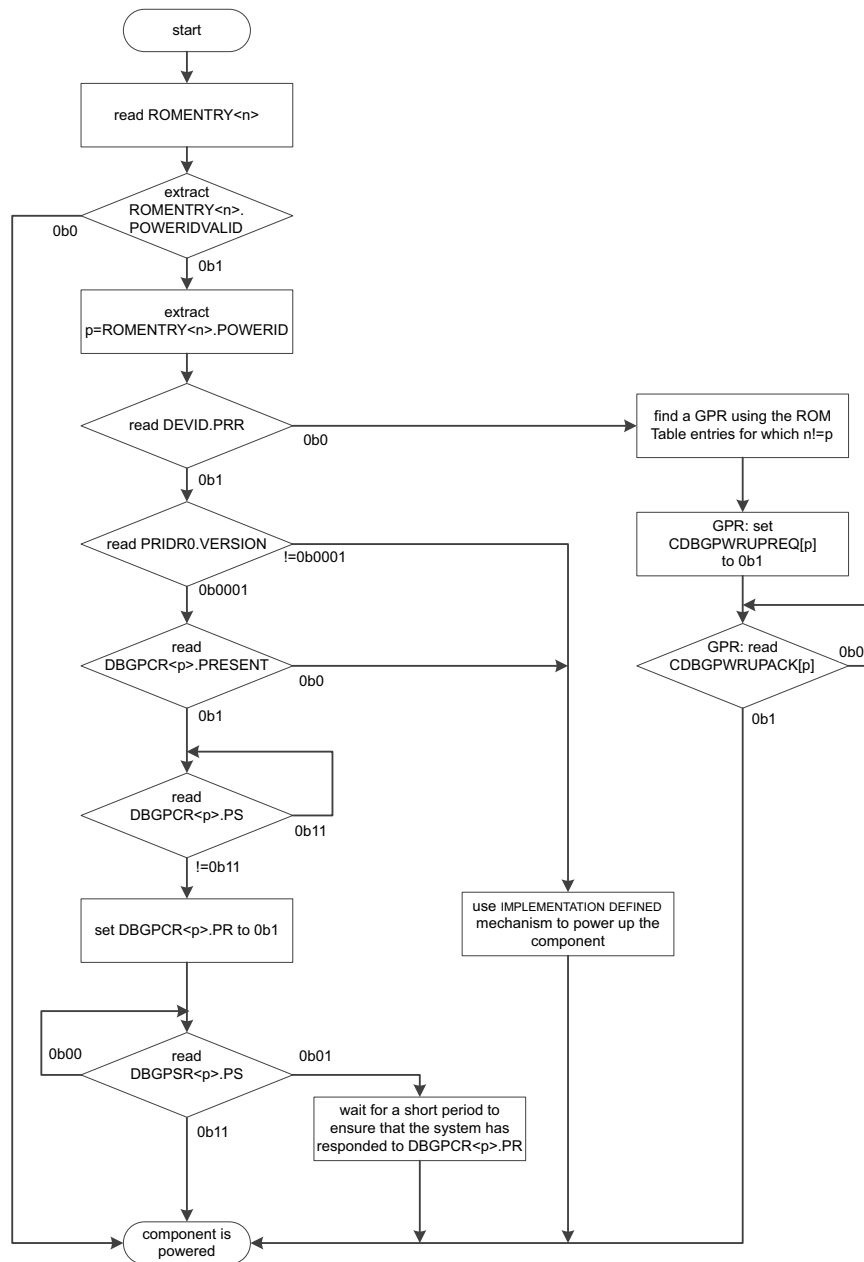

Figure D3-3 Debug power request process

A power request for a component must be removed if one of the following applies:

- The component is no longer in use. Removing the power request allows the system to consider removing power to the power domain that includes the component.
- A mechanism to preserve the component state after it is powered down is in place, for example an automated save and restore mechanism.

The process for removing a power request for a debug component is shown in Figure D3-4.

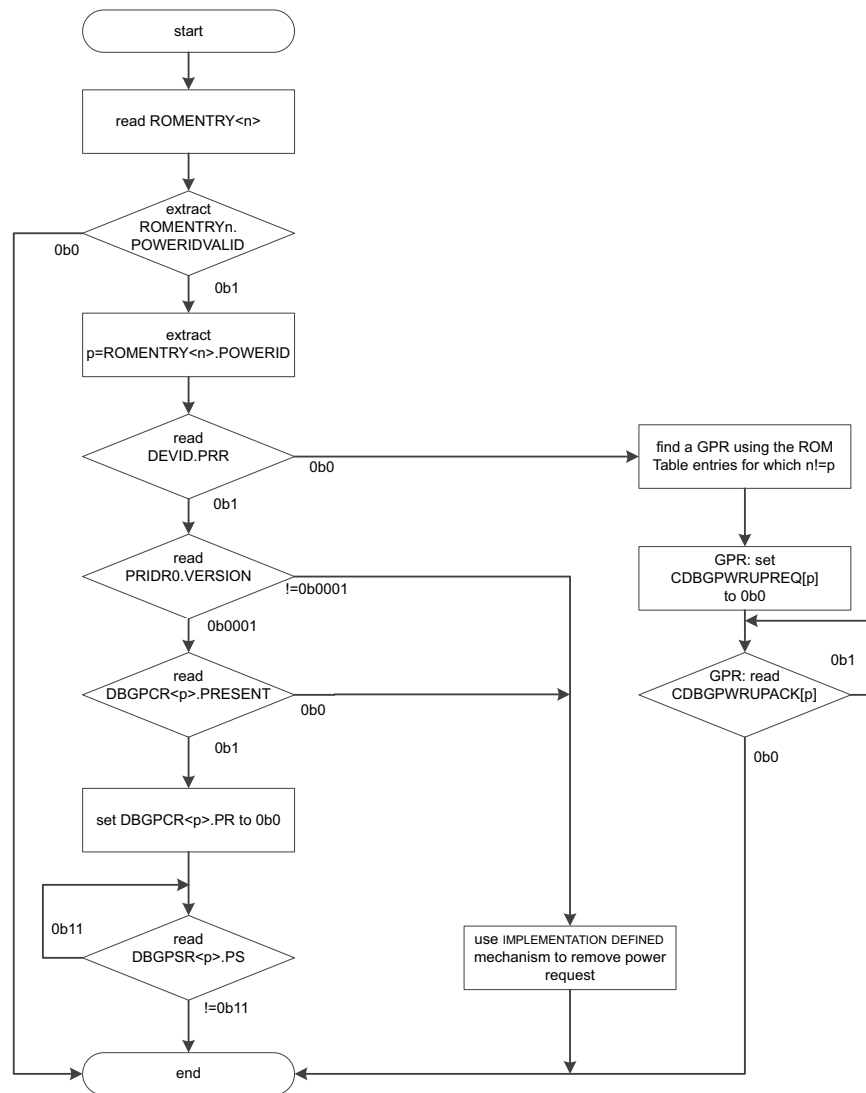

Figure D3-4 Debug power request removal process

It is IMPLEMENTATION DEFINED whether powerup requests using `DBGPCR<n>` registers are affected by the authentication interface, and one of the following applies:

- The powerup requests are considered Non-invasive debug functions, and are ignored when all debug is disabled. This is the Arm recommended behavior.
- The powerup requests are considered Non-secure invasive debug functions, and are ignored when all invasive debug is disabled.
- The powerup requests are considered Root invasive debug functions, and are ignored when Root invasive debug is disabled.
- The powerup requests are considered Secure invasive debug functions and are ignored when Secure invasive debug is disabled.
- The powerup requests are not affected by the authentication interface.

———— **Note** ————

Arm® Realm Management Extension (RME) System Architecture places requirements on power state transitions to ensure the RME security guarantees. These requirements apply to powerup requests from a Class 0x9 ROM Table.

D3.3.4 System power requests

A debugger might need to access power domains that are supported by the system, but for which no power domain IDs are defined in the ROM Table. Examples include power domains for the system interconnect, and normal system memory. The power request functionality for these systems might include optional system power request controls.

It is IMPLEMENTATION DEFINED which system power domains are associated with a system power request.

The process for issuing a power request for a system component is shown in Figure D3-5.

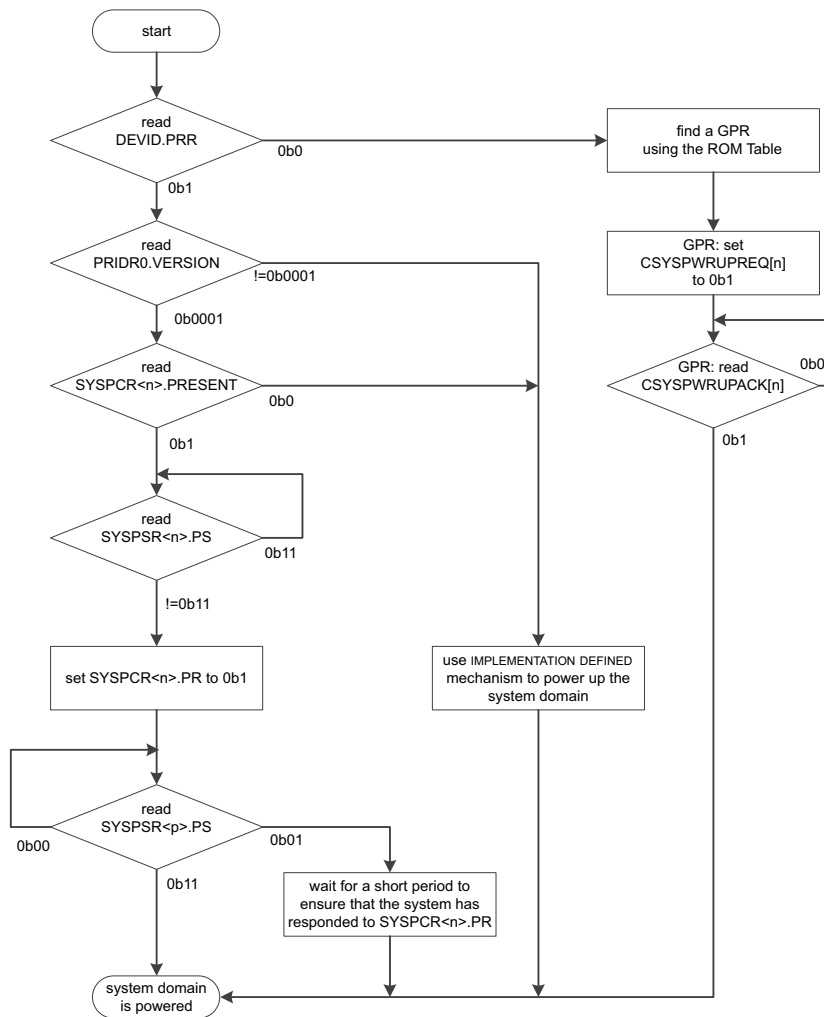

Figure D3-5 System power request process

The process for removing a power request for a system component is shown in Figure D3-6.

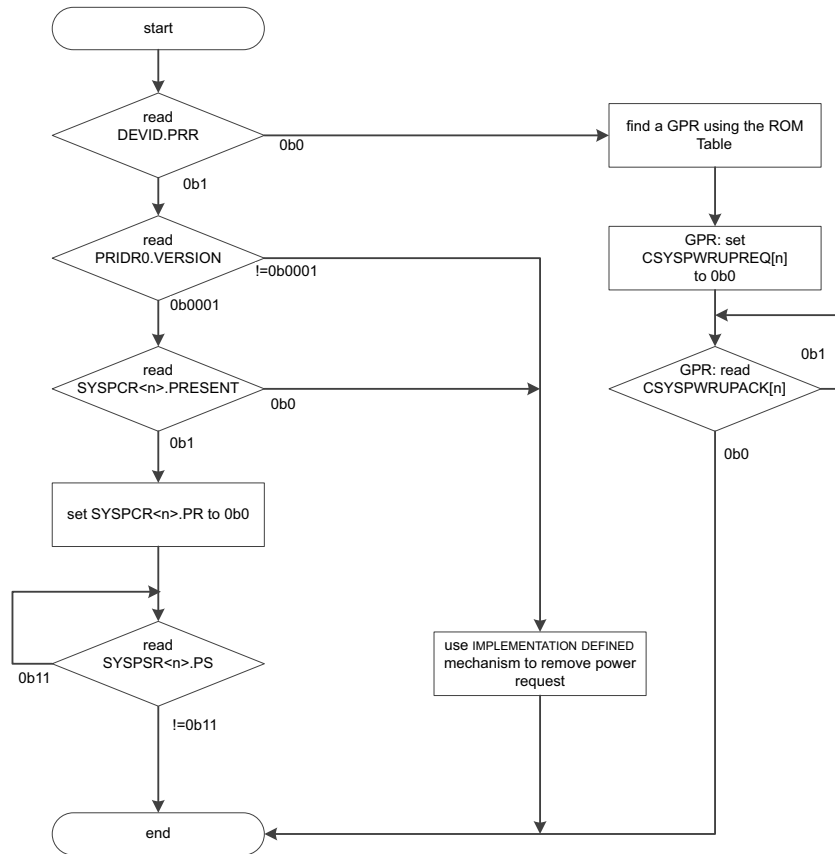

Figure D3-6 System power request removal process

It is IMPLEMENTATION DEFINED whether powerup requests using SYSPCR<n> registers are affected by the authentication interface. One of the following applies for powerup request considerations:

- The powerup requests are considered Non-invasive debug functions, and are ignored when all debug is disabled. This is the Arm recommended behavior.
- The powerup requests are considered Non-secure invasive debug functions, and are ignored when all invasive debug is disabled.
- The powerup requests are considered Root invasive debug functions, and are ignored when Root invasive debug is disabled.
- The powerup requests are considered Secure invasive debug functions and are ignored when Secure invasive debug is disabled.
- The powerup requests are not affected by the authentication interface.

———— **Note** ————

Arm® Realm Management Extension (RME) System Architecture places requirements on power state transitions to ensure the RME security guarantees. These requirements apply to powerup requests from a Class 0x9 ROM Table.

D3.4 Reset control

The reset control registers in the ROM Table can be used to issue reset requests:

- The debug power control registers, [DBGRSTRR](#) and [DBGRSTAR](#), can be used to manage a reset request for a debug reset domain, as described in [Debug reset control](#).
- The system power control registers, [SYSRSTRR](#) and [SYSRSTAR](#), can be used to manage a reset request for a system reset domain, as described in [System reset control](#) on page D3-326.

For detailed descriptions of the ROM Table registers, see [Register descriptions](#) on page D3-328.

D3.4.1 Debug reset control

The [DBGRSTRR](#) in a Class 0x9 ROM Table provides a debug logic reset request function.

The process for issuing a reset request for a debug component is shown in [Figure D3-7](#). When performing a debug reset request, the debugger must proceed through each step of this process.

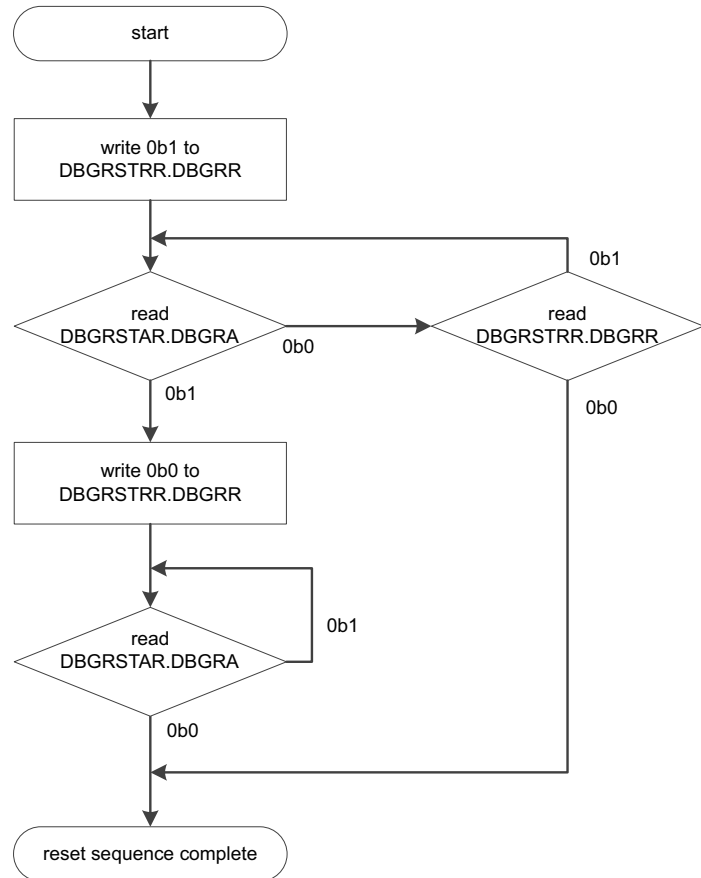

Figure D3-7 Debug reset request process

When a debug reset request is issued using [DBGRRSTRR.DBGRR](#) and the debug reset is performed, it is IMPLEMENTATION DEFINED how long the debug logic is held in reset, and is one of the following:

- [DBGRRSTAR.DBGRA](#) takes the value 0b1 in response to the debug reset starting. The debug logic is held in reset for the entire period that [DBGRRSTRR.DBGRR](#) == 0b1 and [DBGRRSTAR.DBGRA](#) == 0b1. When [DBGRRSTRR.DBGRR](#) becomes 0b0, either due to being explicitly written or due to being reset by the debug reset, [DBGRRSTAR.DBGRA](#) becomes 0b0 after the debug logic has been released from reset.
- The debug logic is reset in response to a rising edge on [DBGRRSTRR.DBGRR](#) and is released from reset without waiting for [DBGRRSTRR.DBGRR](#) to become 0b0. [DBGRRSTAR.DBGRA](#) takes the value 0b1 in response to the debug logic being released from reset. When [DBGRRSTRR.DBGRR](#) becomes 0b0, either due to being explicitly written or due to being reset by the debug reset, [DBGRRSTAR.DBGRA](#) becomes 0b0 in response to the deassertion of [DBGRRSTRR.DBGRR](#).

If the Realm Management Extension is implemented and not disabled, reset requests using [DBGRRSTRR](#) registers are considered to be Root invasive debug functions. When Root invasive debug is disabled, debug reset requests are ignored and it is IMPLEMENTATION DEFINED whether writes to [DBGRRSTRR](#) are also ignored.

If the Realm Management Extension is not implemented or is disabled, and if the system implements separate Secure and Non-secure functionality, reset requests using [DBGRRSTRR](#) registers are considered to be Secure invasive debug functions. When Secure invasive debug is disabled, debug reset requests are ignored and it is IMPLEMENTATION DEFINED whether writes to [DBGRRSTRR](#) are also ignored.

If the system does not implement separate Secure and Non-secure functionality, reset requests using [DBGRRSTRR](#) registers are considered to be invasive debug functions. When invasive debug is disabled, debug reset requests are ignored and it is IMPLEMENTATION DEFINED whether writes to [DBGRRSTRR](#) are also ignored.

D3.4.2 System reset control

The [SYSRRSTRR](#) and [SYSRRSTAR](#) in a Class 0x9 ROM Table provide a system reset request function.

When [SYSRRSTRR.SYSRR](#) is 0b1, the system must be held in reset. When [SYSRRSTRR.SYSRR](#) is 0b1, a reset of any debug logic, for example the debug interface and logic on a processor, is permitted to happen, but the debug logic must be released from reset as soon as it has been reset. Releasing the debug logic allows a debugger to configure the debug logic while holding the system in reset, resulting in the debug logic being programmed and operating immediately after the system reset is released.

———— **Note** —————

If [SYSRRSTRR.SYSRR](#) is reset by either a system reset or a debug reset, the system is not held in reset.

This function is similar to the **nSRST** function provided on some physical debug ports, see [System reset control behavior](#) on page B2-89.

The process for issuing a system reset request is shown in [Figure D3-8](#) on page D3-327. When performing a system reset request, the debugger must proceed through each step of this process.

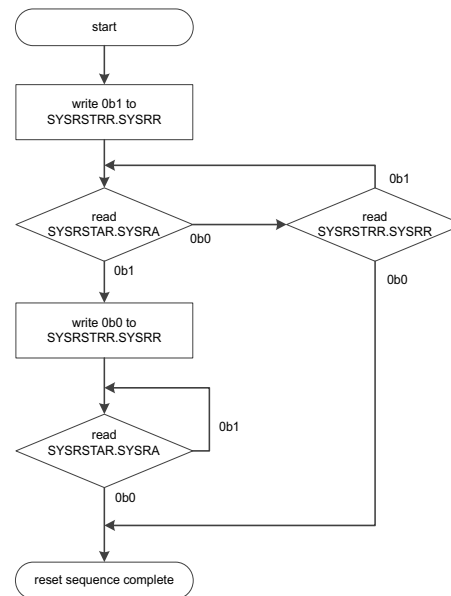

Figure D3-8 System reset request process

If the Realm Management Extension is implemented and not disabled, reset requests using **SYSRSTRR** registers are considered to be Root invasive debug functions. When Root invasive debug is disabled, system reset requests are ignored and it is IMPLEMENTATION DEFINED whether writes to **SYSRSTRR** are also ignored.

If the Realm Management Extension is not implemented or is disabled, and if the system implements separate Secure and Non-secure functionality, reset requests using **SYSRSTRR** registers are considered to be Secure invasive debug functions. When Secure invasive debug is disabled, system reset requests are ignored and it is IMPLEMENTATION DEFINED whether writes to **SYSRSTRR** are also ignored.

If the system does not implement separate Secure and Non-secure functionality, reset requests using **SYSRSTRR** registers are considered to be invasive debug functions. When invasive debug is disabled, system reset requests are ignored and it is IMPLEMENTATION DEFINED whether writes to **SYSRSTRR** are also ignored.

D3.5 Register descriptions

D3.5.1 AUTHSTATUS, Authentication Status Register

The **AUTHSTATUS** characteristics are:

Purpose

AUTHSTATUS indicates whether certain functions are enabled.

Usage constraints

If any field in **AUTHSTATUS** indicates that a level of debug is not enabled, access to one or more components indicated by the ROM table contents might not be possible. Debug tools might need to use a mechanism to enable access to the components.

Note

If power requests are not affected by the authentication interface and the ROM table does not support reset requests, this means that the ROM table does not need an authentication interface and all the fields in **AUTHSTATUS** are permitted to have the value 0b00.

AUTHSTATUS is accessible as follows:

Default

RO

Configurations

Included in all implementations.

Attributes

A 32-bit register.

Field Descriptions

The **AUTHSTATUS** bit assignments are:

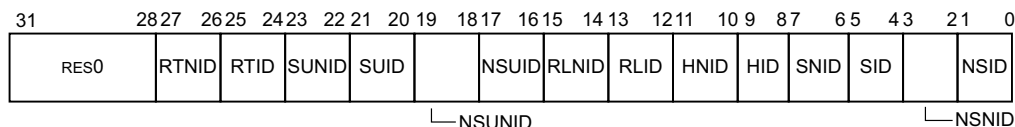

Bits[31:28]

RES0. For more information, see *Arm® Coresight™ Architecture Specification*.

RTNID, bits[27:26]

Root non-invasive debug. For more information, see *Arm® Coresight™ Architecture Specification*.

RTID, bits[25:24]

Root invasive debug. For more information, see *Arm® Coresight™ Architecture Specification*.

SUNID, bits[23:22]

Secure Unprivileged non-invasive debug.

This field always takes the value 0b00, indicating this level of debug is not supported.

SUID, bits[21:20]

Secure Unprivileged invasive debug.

This field always takes the value 0b00, indicating this level of debug is not supported.

NSUNID, bits[19:18]

Non-secure Unprivileged non-invasive debug.

This field always takes the value 0b00, indicating this level of debug is not supported.

NSUID, bits[17:16]

Non-secure Unprivileged invasive debug.

This field always takes the value 0b00, indicating this level of debug is not supported.

RLNID, bits[15:14]

Realm non-invasive debug. For more information, see *Arm® Coresight™ Architecture Specification*.

RLID, bits[13:12]

Realm invasive debug. For more information, see *Arm® Coresight™ Architecture Specification*.

HNID, bits[11:10]

Hypervisor non-invasive debug.

This field always takes the value 0b00, indicating this level of debug is not supported.

HID, bits[9:8]

Hypervisor invasive debug.

This field always takes the value 0b00, indicating this level of debug is not supported.

SNID, bits[7:6]

Secure noninvasive debug. For more information, see *Arm® Coresight™ Architecture Specification*.

SID, bits[5:4]

Secure invasive debug. For more information, see *Arm® Coresight™ Architecture Specification*.

NSNID, bits[3:2]

Non-secure noninvasive debug. For more information, see *Arm® Coresight™ Architecture Specification*.

NSID, bits[1:0]

Non-secure invasive debug. For more information, see *Arm® Coresight™ Architecture Specification*.

Accessing AUTHSTATUS

[AUTHSTATUS](#) can be accessed at the following address:

Component	Offset
ROM Table	0xFB8

D3.5.2 CIDR0-CIDR3, Component Identification Registers

This section describes the bit assignments for ROM Table components.

The **CIDR0-CIDR3** characteristics are:

Purpose

Provide information to identify a CoreSight component.

Usage constraints

CIDR0-CIDR3 are accessible as follows:

Default
RO

Configurations

Included in all implementations.

Attributes

Four 32-bit management registers.

Field Descriptions

The **CIDR0-CIDR3** bit assignments are:

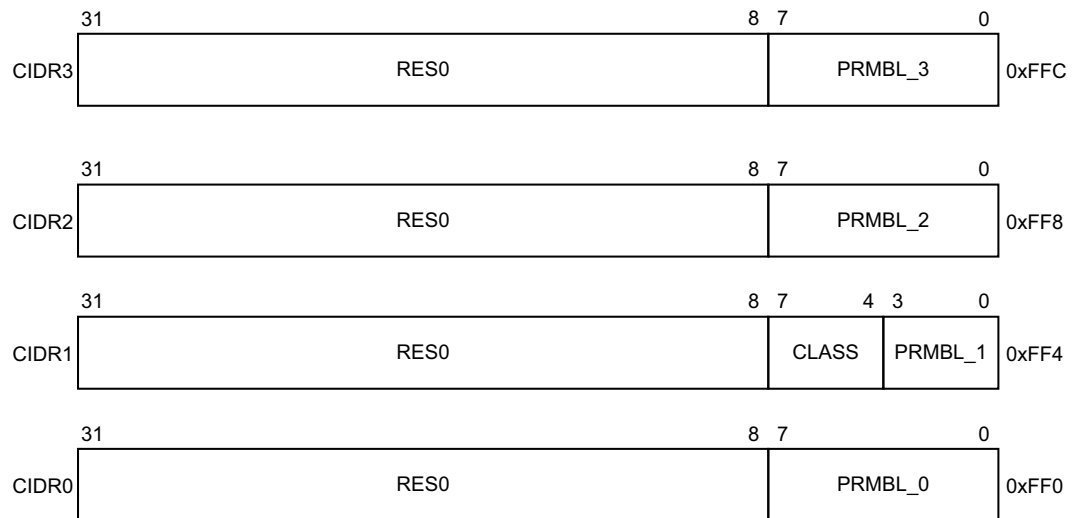

CIDR3 bits[31:8]

RES0.

PRMBL_3, CIDR3 bits[7:0]

0xB1.

CIDR2 bits[31:8]

RES0.

PRMBL_2, CIDR2 bits[7:0]

0x05.

CIDR1 bits[31:8]

RES0.

CLASS, CIDR1 bits[7:4]

0x9 CoreSight component.

PRMBL_1, CIDR1 bits[3:0]

0x0.

CIDR0 bits[31:8]

RES0.

PRMBL_0, CIDR0 bits[7:0]

0x0D.

Accessing CIDR0-CIDR3

CIDR0-CIDR3 can be accessed at the following address:

Component	Offset			
	CIDR0	CIDR1	CIDR2	CIDR3
ROM Table	0xFF0	0xFF4	0xFF8	0xFFC

D3.5.3 CLAIMSET and CLAIMCLR, Claim Tag Set Register and Claim Tag Clear Register

The CLAIMSET and CLAIMCLR characteristics are:

Purpose

CLAIMSET and CLAIMCLR provide various bits that can be separately set and cleared to indicate whether functionality is in use by a debug agent.

For a Class 0x9 ROM Table, no claim tags are implemented.

Usage constraints

CLAIMSET and CLAIMCLR are accessible as follows:

CLAIMSET	CLAIMCLR
RW	RW

Configurations

Included in all implementations.

Attributes

A set of 32-bit registers.

Field Descriptions

The CLAIMSET and CLAIMCLR bit assignments are:

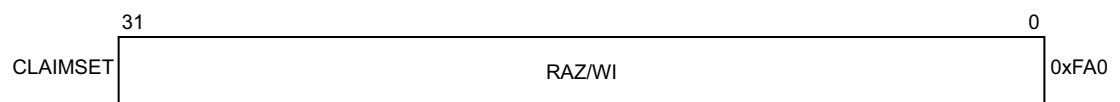
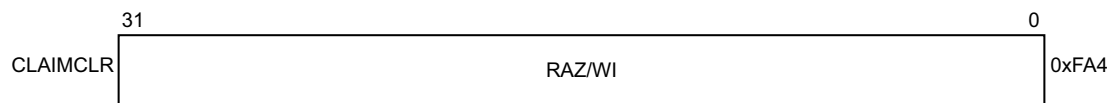

CLAIMCLR, bits[31:0]

RAZ/WI, which corresponds to 0 claim tags being used.

CLAIMSET, bits[31:0]

RAZ/WI, which corresponds to 0 claim tags being used.

Accessing CLAIMSET-CLAIMCLR

CLAIMSET and CLAIMCLR can be accessed at the following addresses:

Component	Offset	
	CLAIMSET	CLAIMCLR
ROM Table	0xFA0	0xFA4

D3.5.4 DBGPCR<n>, Debug Power Control Registers

The DBGPCR<n> characteristics are:

Purpose

Power request version 0 supports up to 32 debug power domains, with separate registers for each debug domain that provide controls for power requests.

The register that controls power requests for debug power domain *n* is DBGPCR<n>. DBGPCR<n> is used for the following purposes:

- To indicate whether a power request mechanism is implemented for debug power domain *n*.
- To request power to debug power domain *n*.

Usage constraints

Debug power requests can be ignored in some scenarios. For details, see [Debug power requests on page D3-320](#).

When debug power requests are ignored, then it is IMPLEMENTATION DEFINED whether writes to DBGPCR<n> are also ignored.

DBGPCR<n>are accessible as follows:

Default
RW

Configurations

Only implemented if PRIDR0.VERSION indicates it is implemented.

Attributes

Up to 32 32-bit registers.

Field Descriptions

The DBGPCR<n> bit assignments are:

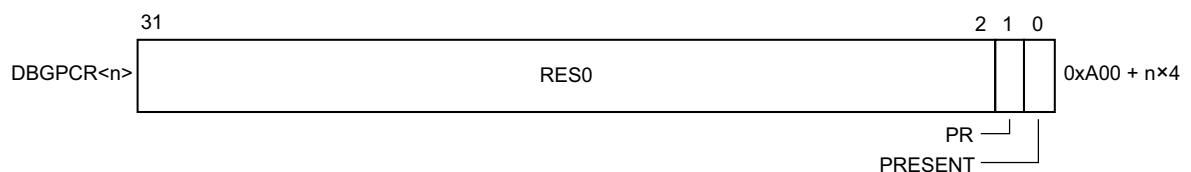

Bits[31:2]

RES0.

PR, bit[1]

Power request. This field can have one of the following values:

0b0 Power is not requested for debug power domain *n*.

0b1 Power is requested for debug power domain *n*.

This field is reserved if **DBGPCR<n>.PRESENT** is 0b0, which indicates that power requests are not implemented for debug power domain *n*.

PRESENT, bit[0]

This RO field is IMPLEMENTATION DEFINED, and indicates whether the power request for debug power domain *n* is implemented. PRESENT can have one of the following values:

0b0 Power request for debug power domain *n* is not implemented.

0b1 Power request for debug power domain *n* is implemented, and therefore **DBGPCR<n>.PR** and **DBGPSR<n>** are also implemented.

If, for a **ROMENTRY<m>** with a **POWERIDVALID** value of 0b1 and a **POWERID** value of *n*, a read of **DBGPCR<n>.PRESENT** returns a value of 0b0, the mechanism to power up the debug power domain with the ID *n* is IMPLEMENTATION DEFINED.

Arm recommends that debug tools do not attempt accesses to components where **ROMENTRY<m>.POWERIDVALID** is 0b1 without first powering up the component using either the **DBGPCR<n>** register or an IMPLEMENTATION DEFINED method.

Accessing the DBGPCR<n>

The **DBGPCR<n>** for debug power domain *n* can be accessed at the following address:

Component	Offset
ROM Table	0xA00 + <i>n</i> ×4

D3.5.5 DBGPSR<n>, Debug Power Status Registers

The **DBGPSR<n>** characteristics are:

Purpose

Power request version 0 supports up to 32 debug power domains, with separate registers for each domain providing controls for power requests.

The register that indicates the current power status for debug power domain *n* is **DBGPSR<n>**.

Usage constraints

DBGPSR<n> are accessible as follows:

Default
RO

Configurations

Only implemented if **DBGPCR<n>.PRESENT** is 1.

Attributes

Up to 32 32-bit registers.

Field Descriptions

The `DBGPSR<n>` bit assignments are:

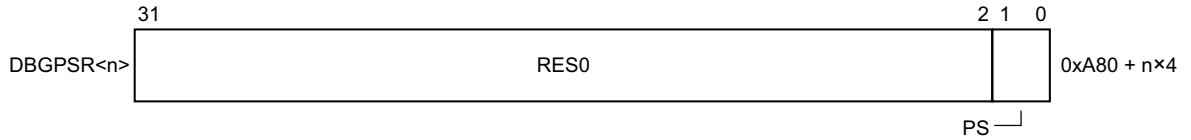

Bits[31:2]

RES0.

PS, bits[1:0]

Power status of debug power domain n . This field can have one of the following values:

- 0b00 Debug power domain n might not be powered.
- 0b01 Debug power domain n is powered.
- 0b10 Reserved.
- 0b11 Debug power domain n is powered and must remain powered until `DBGPCR<n>.PR` is set to 0b0.

An implementation of the power request mechanism is not expected to be capable of indicating both the 0b01 and 0b11 values of `DBGPSR<n>.PS`:

- When `DBGPSR<n>.PS` reads as 0b01, power is applied to debug power domain n . If `DBGPCR<n>.PR` is 0b1, Arm recommends that power to debug power domain n is continually maintained until `DBGPCR<n>.PR` is set to 0b0, to ensure that debug-related programmed state is not lost during a debug session.
- When `DBGPSR<n>.PS` can read as 0b11, the four-phase handshake with `DBGPCR<n>.PR`, shown in Figure D3-9, guarantees that debug power domain n is powered when required.

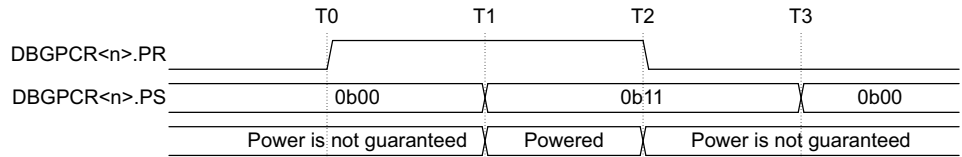

Figure D3-9 Power handshake

The steps in Figure D3-9 are:

- At T_0 , `DBGPCR<n>.PR` is written with 0b1 to request power.
- At T_1 , `DBGPSR<n>.PS` is set to 0b11 to indicate that the power request has been seen and power has been provided and is maintained.
- At T_2 , `DBGPCR<n>.PR` is written with 0b0 to clear the power request.
- At T_3 , `DBGPSR<n>.PS` is cleared to 0b00 to acknowledge that the power request has been removed.

Between T_1 and T_2 , power must be supplied to power domain n , and must not be removed. If T_1 is never reached because the system cannot power up the domain, `DBGPSR<n>.PS` must remain 0b00. The debugger might choose to remove the power request by writing 0b0 to `DBGPCR<n>.PR`, although this practice is not recommended.

`DBGPCR<n>.PR` must not be used to initiate a power request when `DBGPSR<n>.PS` reads as 0b11, because this value indicates that the handshake from a previous request is still completing.

Accessing the DBGPSR<n>

The [DBGPSR<n>](#) for debug power domain n can be accessed at the following address:

Component	Offset
ROM Table	$0xA80 + n \times 4$

D3.5.6 DBGRSTAR, Debug Reset Acknowledge Register

The [DBGRSTAR](#) characteristics are:

Purpose

Used to indicate that a debug reset has been completed, as an acknowledgment to a request that was made by using [DBGRSTRR](#).

Usage constraints

[DBGRSTAR](#) is accessible as follows:

Default
RO

Configurations

[PRIDR0](#).DBGRR indicates whether this register is implemented.

Attributes

A 32-bit register.

Field Descriptions

The [DBGRSTAR](#) bit assignments are:

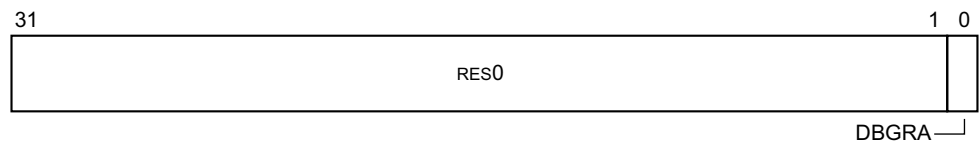

Bits[31:1]

RES0.

DBGRA, bit[0]

Debug Reset Acknowledge:

0b0 The debug reset request has not initiated, or has been completed in response to [DBGRSTRR](#).DBGRR being deasserted.

0b1 The debug reset request has been initiated.

After a power-on reset, this field is set to 0b0.

Accessing DBGRSTAR

[DBGRSTAR](#) can be accessed at the following address:

Component	Offset
ROM Table	0xC14

D3.5.7 DBGRSTRR, Debug Reset Request Register

The [DBGRSTRR](#) characteristics are:

Purpose

[DBGRSTRR](#) is used to request a reset of debug functionality.

[DBGRSTRR](#) is used with [DBGRSTAR](#) in a handshake mechanism that indicates when a reset has been completed.

Usage constraints [PRIDR0.DBGRR](#) indicates whether this register is implemented.

When debug reset requests are ignored, then it is IMPLEMENTATION DEFINED whether writes to [DBGRSTRR](#) are also ignored. See *Debug reset control on page D3-325*.

The [DBGRSTRR](#) register is accessible as follows:

Default

RW

Configurations

[PRIDR0.DBGRR](#) indicates whether this register is implemented.

Attributes

A 32-bit register.

Field Descriptions

The [DBGRSTRR](#) bit assignments are:

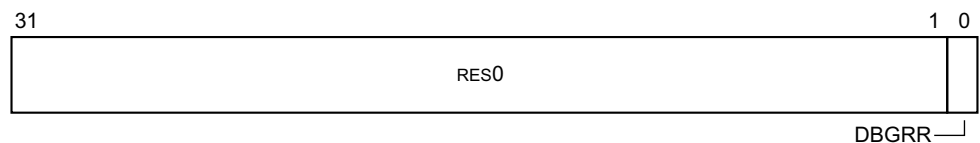

Bits[31:1]

RES0.

DBGRR, bit[0]

Debug Reset Request:

0b0 A debug reset is not requested.

0b1 A debug reset is requested. The request remains asserted until this field is explicitly overwritten with the value 0b0.

After a power-on reset, this field is set to 0b0.

Whether a debug reset request also resets [DBGRSTRR](#) is IMPLEMENTATION DEFINED. If [DBGRSTRR](#) is reset by a debug reset, [DBGRR](#) is reset to 0b0, and the reset process is complete.

Setting [DBGRSTRR.DBGRR](#) to 0b0 when [DBGRSTAR.DBGRA](#) is not 0b1 results in UNPREDICTABLE behavior, and a debug reset might or might not occur.

Accessing DBGRSTRR

DBGRSTRR can be accessed at the following address:

Component	Offset
ROM Table	0xC10

D3.5.8 DEVAFF0-DEVAFF1, Device Affinity Registers

The DEVAFF0-DEVAFF1 characteristics are:

Purpose

Enables a debugger to determine whether two components have an affinity with each other.

Usage constraints

DEVAFF0-DEVAFF1 are accessible as follows:

Default
RO

Configurations

Included in all implementations.

Attributes

Two 32-bit registers. A component might have an affinity with a group of components, for example where a single component is shared between multiple PEs. DEVAFF0-DEVAFF1 can be used to indicate the affinity with a group of components. See the relevant *Arm® Architecture Reference Manual* for examples of how affinity with groups of PEs is indicated. However, indicating affinity with one component or group of components is optional. When affinity is not indicated, these fields are RAZ.

Field Descriptions

The DEVAFF0-DEVAFF1 bit assignments are:



DEVAFF0, bits[31:0]

DEVAFF1, bits[31:0]

IMPLEMENTATION DEFINED.

Accessing DEVAFF0-DEVAFF1

DEVAFF0-DEVAFF1 can be accessed at the following addresses:

Component	Offset	
	DEVAFF0	DEVAFF1
ROM Table	0xFA8	0xFAC

D3.5.9 DEVARCH, Device Architecture Register

The DEVARCH characteristics are:

Purpose

Identifies the architect and architecture of a CoreSight component.

Usage constraints

DEVARCH is accessible as follows:

Default

RO

Configurations

Included in all implementations.

Attributes

A 32-bit register.

Field Descriptions

The DEVARCH bit assignments are:

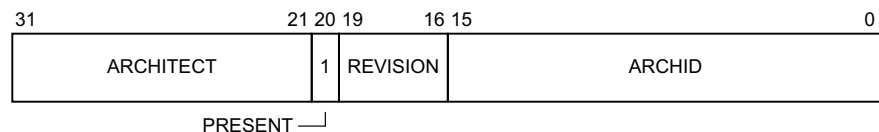

ARCHITECT, bits[31:21]

0x23B Arm.

PRESENT, bit[20]

0b1 Present.

REVISION, bits[19:16]

0x0 Revision 0.

ARCHID, bits[15:0]

0x0AF7 ROM Table v0. If this value of ARCHID is found, the debug tool must inspect DEVTYPER and DEVID to determine further information about the ROM Table.

Accessing DEVARCH

DEVARCH can be accessed at the following address:

Component	Offset
ROM Table	0xFBC

D3.5.10 DEVID, Device Configuration Register

The DEVID characteristics are:

Purpose

Indicates the capabilities of the component.

Usage constraints

DEVID is accessible as follows:

Default
RO

Configurations

Included in all implementations.

Attributes

A 32-bit register.

Field Descriptions

The DEVID bit assignments are:

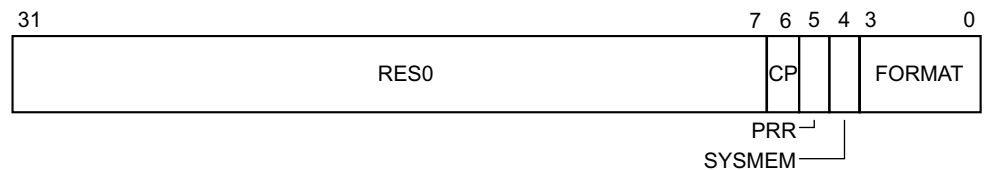

Bits[31:7]

RES0.

CP[6]

- 0b0 COM Port functionality is not present. Offset range 0xD00-0xD7C is RES0.
- 0b1 COM Port functionality is present. Offset range 0xD00-0xD7C contain COM Port functionality. Offset 0xD00 indicates the COM Port programmers' model.

PRR, bit[5]

Power Request functionality included. This field can have one of the following values:

- 0b0 Power Request functionality not included.
If any ROM Table entries contain power domain IDs, a GPR must be present, and pointed to by the ROM Table. The GPR provides functionality to control the power domains.
PRIDR0 is not implemented.
- 0b1 Power Request functionality included.

If any ROM Table entries contain power domain IDs, they are controlled by the Power Request functionality in the ROM Table.

[PRIDR0](#) is implemented.

See also [PRIDR0, Power Request ID Register 0](#) on page D3-346.

SYSTEMEM, bit[4]

System memory present. Indicates whether system memory is present on the bus that connects to the ROM Table. The possible values are:

0b0 System memory not present on bus. This value indicates that the bus is a dedicated debug bus.

0b1 System memory is also present on this bus.

Use of SYSTEMEM by software is deprecated, and debuggers should ignore the value of this field.

Setting SYSTEMEM to 0b1 is deprecated, and SYSTEMEM is permitted to have the value 0b0 in systems where there are other valid addresses in the memory system.

MEMTYPE.SYSTEMEM indicates the memory accesses that can be performed:

When SYSTEMEM is 0b0

The ROM Table indicates all the valid addresses in the memory system, and the result of accessing any other address is UNPREDICTABLE. For more information, see [The component address](#) on page D1-293.

When SYSTEMEM is 0b1

There might be other valid addresses in the memory system. The result of accessing these addresses is IMPLEMENTATION DEFINED, and:

- The ADI specification does not include any mechanism that can be used to discover what addresses it can access, other than the addresses that are listed in the ROM Table.
- If accesses are performed to addresses that are not in the ROM Table, there can be side effects on the system.

FORMAT, bits[3:0]

ROM format. This field can have one of the following values:

0x0 32-bit format 0.

0x1 64-bit format 1.

Values 0x2-0xF are reserved.

Accessing DEVID

[DEVID](#) can be accessed at the following address:

Component	Offset
ROM Table	0xFC8

D3.5.11 DEVID1-DEVID2, Device Configuration Registers

The [DEVID1-DEVID2](#) characteristics are:

Purpose

Indicates the capabilities of the component.

Usage constraints

[DEVID1-DEVID2](#) are accessible as follows:

Default

RO

Configurations

Included in all implementations.

Attributes

Two 32-bit registers.

Field Descriptions

The [DEVID1-DEVID2](#) bit assignments are:

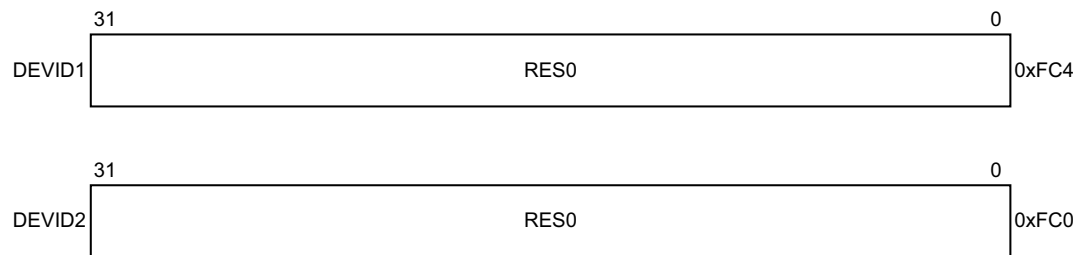

DEVID1, bits[31:0]

DEVID2, bits[31:0]

RES0.

Accessing DEVID1-DEVID2

[DEVID1-DEVID2](#) can be accessed at the following addresses:

Component	Offset	
	DEVID1	DEVID2
ROM Table	0xFC4	0xFC0

D3.5.12 DEVTYPE, Device Type Register

The [DEVTYPE](#) characteristics are:

Purpose

A debugger can use [DEVTYPE](#) to obtain information about a component that has an unrecognized Part number.

Usage constraints

[DEVTYPE](#) is accessible as follows:

Default

RO

Configurations

Included in all implementations.

Attributes

A 32-bit register.

Field Descriptions

The **DEVTYPE** bit assignments are:

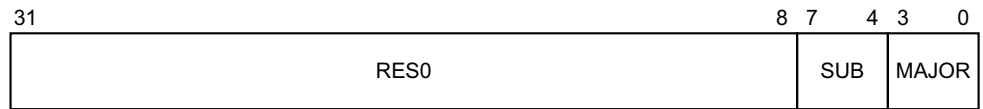

Bits[31:8]

RES0.

SUB, bits[7:4]

0x0 Other, undefined.

MAJOR, bits[3:0]

0x0 Miscellaneous.

Accessing DEVTYPE

DEVTYPE can be accessed at the following address:

Component	Offset
ROM Table	0xFCC

D3.5.13 ITCTRL, Integration Mode Control Register

The **ITCTRL** characteristics are:

Purpose

A component can use **ITCTRL** to dynamically switch between functional mode and integration mode.

For a Class 0x9 ROM Table, this mechanism is not implemented.

Usage constraints

ITCTRL is accessible as follows:

Default
RW

Configurations

Included in all implementations.

Attributes

A 32-bit register.

Field Descriptions

The [ITCTRL](#) bit assignments are:

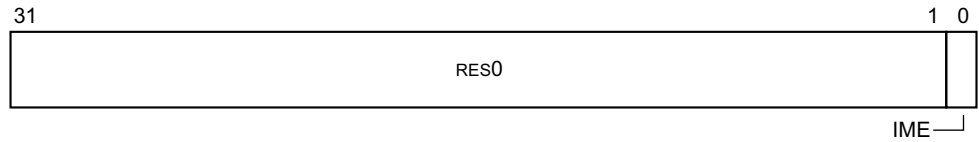

Bits[31:1]

RES0.

IME, bit[0]

RES0, which indicates that no integration functionality is implemented.

Accessing ITCTRL

[ITCTRL](#) can be accessed at the following address:

Component	Offset
ROM Table	0xF00

D3.5.14 LAR and LSR, Software Lock Access Register and Software Lock Status Register

The [LAR](#) and [LSR](#) characteristics are:

Purpose

The Software lock mechanism prevents accidental access to the registers of CoreSight components. For a Class 0x9 ROM Table, the lock mechanism is not implemented.

Usage constraints

[LAR](#) and [LSR](#) are accessible as follows:

LAR	LSR
WO	RO

Configurations

Included in all implementations.

Attributes

A set of 32-bit registers.

Field Descriptions

The [LAR](#) and [LSR](#) bit assignments are:

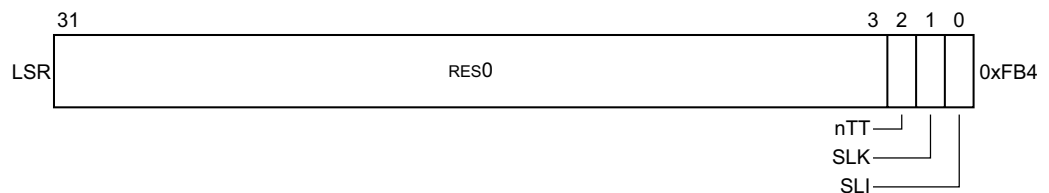

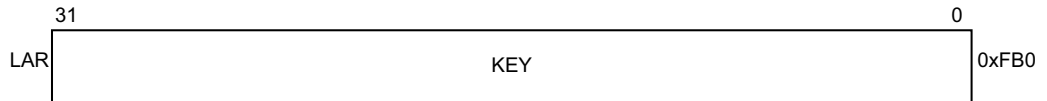

LSR, bits[31:3]

RES0.

nTT, LSR bit[2]

RAZ.

SLK, LSR bit[1]

RAZ.

SLI, LSR bit[0]

RAZ.

KEY, LAR bits[31:0]

WI.

Accessing LAR and LSR

LAR and LSR can be accessed at the following addresses:

Component	Offset	
	LAR	LSR
ROM Table	0xFB0	0xFB4

D3.5.15 PIDR0-PIDR7, Peripheral Identification Register

This section describes the bit assignments for ROM Table components.

The [PIDR0-PIDR7](#) characteristics are:

Purpose

Provide information to identify a CoreSight component.

Usage constraints

[PIDR0-PIDR7](#) are accessible as follows:

Default
RO

Configurations

Included in all implementations.

Attributes

Eight 32-bit management registers.

Field Descriptions

The [PIDR0-PIDR7](#) bit assignments are:

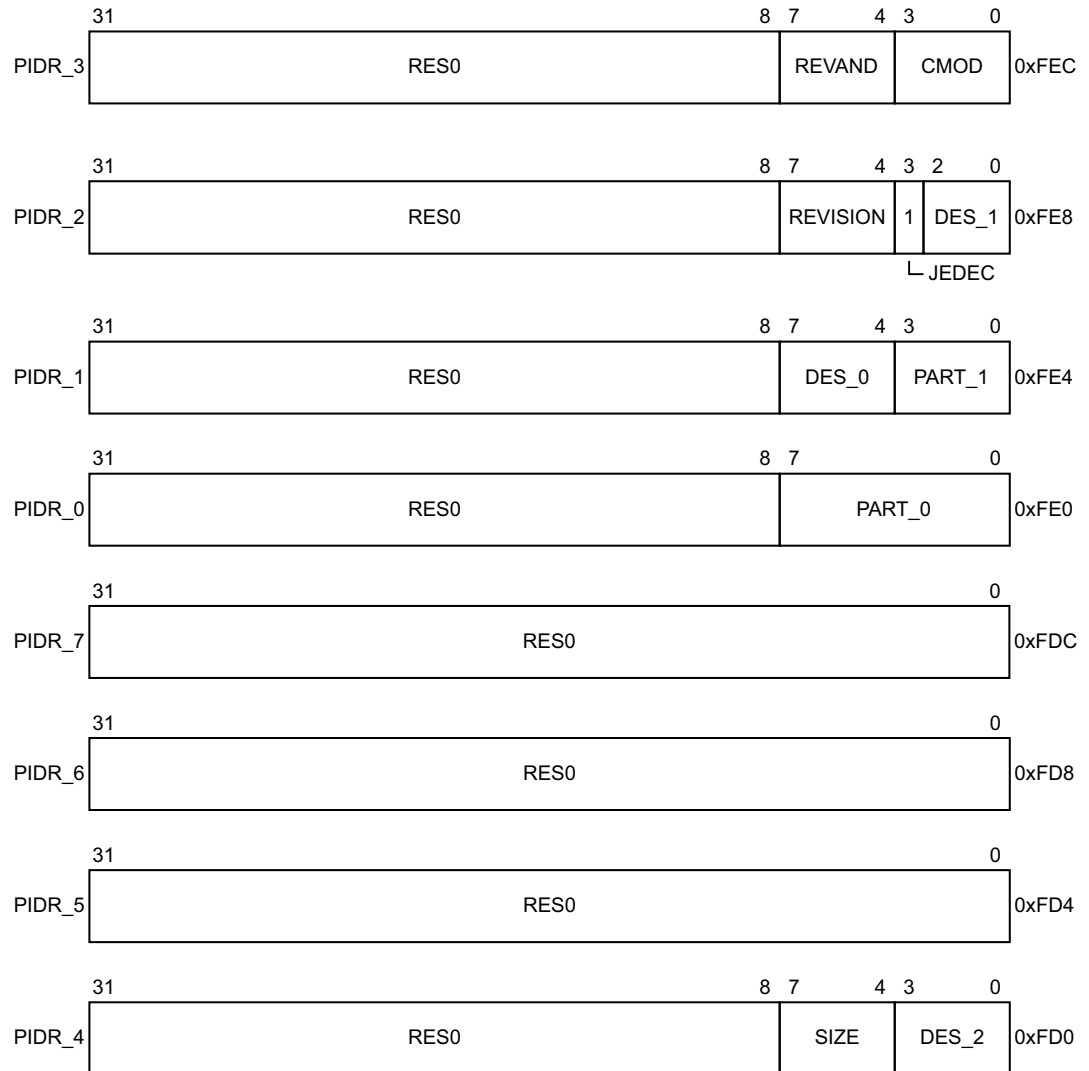

PIDR3 bits[31:8]

RES0.

REVAND, PIDR3 bits[7:4]

See register descriptions in PIDR0-PIDR7 in *Arm® CoreSight™ Architecture Specification*.

CMOD, PIDR3 bits[3:0]

See register descriptions in PIDR0-PIDR7 in *Arm® CoreSight™ Architecture Specification*.

PIDR2 bits[31:8]

RES0.

REVISION, PIDR2 bits[7:4]

See register descriptions in PIDR0-PIDR7 in *Arm® CoreSight™ Architecture Specification*.

JEDEC, PIDR2 bits[3]

0b1 A JEDEC value is used.

DES_1, PIDR2 bits[2:0]

See register descriptions in PIDR0-PIDR7 in *Arm® CoreSight™ Architecture Specification*.

PIDR1 bits[31:8]

RES0.

DES_0, PIDR1 bits[7:4]

See register descriptions in PIDR0-PIDR7 in *Arm® CoreSight™ Architecture Specification*.

PART_1, PIDR1 bits[3:0]

See register descriptions in PIDR0-PIDR7 in *Arm® CoreSight™ Architecture Specification*.

PIDR0 bits[31:8]

RES0.

PART_0, PIDR0 bits[7:0]

See register descriptions in PIDR0-PIDR7 in *Arm® CoreSight™ Architecture Specification*.

PIDR7 bits[31:0]

RES0.

PIDR6 bits[31:0]

RES0.

PIDR5 bits[31:0]

RES0.

PIDR4 bits[31:8]

RES0.

SIZE, PIDR4 bits[7:4]

0x0 A ROM Table occupies a single 4KB block of memory.

DES_2, PIDR4 bits[3:0]

See register descriptions in PIDR0-PIDR7 in *Arm® CoreSight™ Architecture Specification*.

Accessing PIDR0-PIDR7

[PIDR0-PIDR7](#) can be accessed at the following address:

Component	Offset							
	PIDR0	PIDR1	PIDR2	PIDR3	PIDR4	PIDR5	PIDR6	PIDR7
ROM Table	0xFE0	0xFE4	0xFE8	0xFEC	0xFD0	0xFD4	0xFD8	0xFDC

D3.5.16 PRIDR0, Power Request ID Register 0

The [PRIDR0](#) characteristics are:

Purpose

Indicates the features of the power request functionality.

Usage constraints

PRIDR0 is accessible as follows:

Default
RO

Configurations

Only implemented if DEVID.PRR indicates it is implemented.

Attributes

PA 32-bit register.

Field Descriptions

The PRIDR0 bit assignments are:

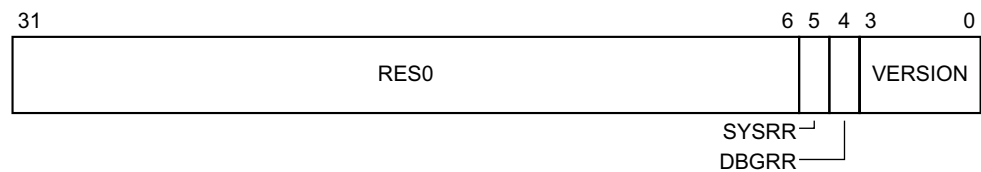

Bits[31:6]

RES0.

SYSRR, bit[5]

Indicates whether the system reset request functionality is present. This field can have one of the following values:

- 0b0 The system reset request functionality is not implemented.
- 0b1 The system reset request functionality, and [SYSRSTRR](#) and [SYSRSTAR](#), which provide status information for system resets, are implemented.

DBGRR, bit[4]

Indicates whether the debug reset request functionality is present. This field can have one of the following values:

- 0b0 The debug reset request functionality is not implemented.
- 0b1 The system reset request functionality, and [DBGRSTRR](#) and [DBGRSTAR](#), which provide status information for debug resets, are implemented.

VERSION, bits[3:0]

Indicates the version of the power request functionality. This field can have one of the following values:

- 0b0000 The power request functionality is not implemented.
- 0b0001 The power request functionality version 0, and [DBGPCR<n>](#), [DBGPSR<n>](#), [SYSPCR<n>](#), and [SYSPSR<n>](#), which provide controls for power requests, are implemented.

Values 0b0010-0b1111 are reserved.

Accessing PRIDR0

PRIDR0 can be accessed at the following address:

Component	Offset
ROM Table	0xC00

D3.5.17 ROMENTRY<n>, Class 0x9 ROM Table entries

The ROMENTRY<n> characteristics are:

Purpose

A Class 0x9 ROM Table contains up to 512 ROM Table entries. Each entry that is present, ROMENTRY<n>, describes a single component, component *n*.

The series of ROM Table entries starts at the base address of the Class 0x9 ROM Table:

- The first entry, entry 0, has offset 0x000.
- For a ROM table with DEVID.FORMAT == 0x0, each entry is 32 bits:
 - ROMENTRY<n> has the offset 0x000 + $n \times 4$, where $0 \leq n \leq 511$.
 - If the number of components, *N*, is lower than the maximum supported number, 512, the offsets of the ROM Table entries are in the following range:
 - ROM Table entries representing components have offsets from 0x000 to $(N-1) \times 4$.
 - The ROMENTRY<n> at offset $N \times 4$, which has a PRESENT field with the value 0b00, indicates the end of the ROM Table.
 - If the number of components is equal to the maximum supported number, the ROM Table entries have offsets from 0x000 to 0x7FC. If a ROM Table entry is present at offset 0x7FC, its PRESENT field must have a value of either 0b00 or 0b11, and it must be interpreted as the final entry of the ROM Table, even if its PRESENT field has the value 0b11.
 - OFFSET[31:12] of ROMENTRY<n> is located in the 32-bit word at offset 0x000 + $(n \times 4)$
- For a ROM table with DEVID.FORMAT == 0x1, each entry is 64 bits:
 - ROMENTRY<n> has the offset 0x000 + $n \times 8$, where $0 \leq n \leq 255$.
 - If the number of components, *N*, is lower than the maximum supported number, 256, the offsets of the ROM Table entries are in the following range:
 - ROM Table entries representing components have offsets from 0x000 to $(N-1) \times 8$.
 - The ROMENTRY<n> at offset $N \times 8$, which has a PRESENT field with the value 0b00, indicates the end of the ROM Table.
 - If the number of components is equal to the maximum supported number, the ROM Table entries have offsets from 0x000 to 0x7F8. If a ROM Table entry is present at offset 0x7F8, its PRESENT field must have a value of either 0b00 or 0b11, and it must be interpreted as the final entry of the ROM Table, even if its PRESENT field has the value 0b11.
 - OFFSET[31:12] of ROMENTRY<n> is located in the 32-bit word at offset 0x000 + $(n \times 8)$
 - OFFSET[63:32] of ROMENTRY<n> is located in the 32-bit word at offset 0x000 + $(n \times 8) + 0x4$

Usage constraints

ROMENTRY<n> registers are accessible as follows:

Default

RO

Configurations

Included in all implementations. For more information, see [The component address on page D1-293](#).

Attributes

Depend on the configuration of the CoreSight DEVID register:

- If DEVID.FORMAT has the value 0x0, the ROMENTRY<n> are 512 32-bit registers.
- If DEVID.FORMAT has the value 0x1, the ROMENTRY<n> are 256 64-bit registers.

Field Descriptions

The ROMENTRY<n> bit assignments are:

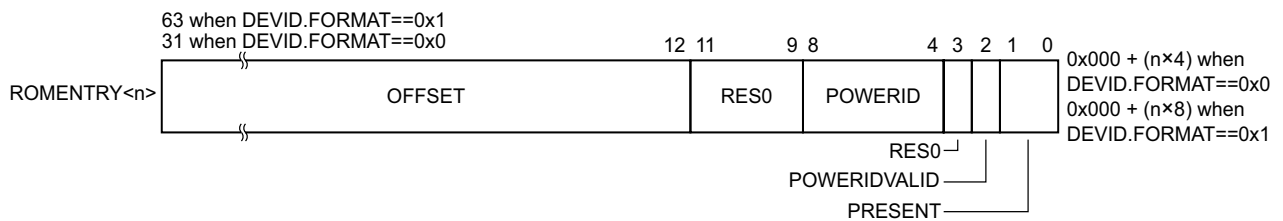

OFFSET, bits[31:12] when DEVID.FORMAT has the value 0x0

OFFSET, bits[63:12] when DEVID.FORMAT has the value 0x1

The component address, relative to the base address of this ROM Table. See [The component address on page D1-293](#) for full details on calculating the component address.

———— **Note** ————

If PRESENT are not 0b00, the OFFSET field of the ROM Table entry must not be zero. A zero address offset points back to this ROM Table.

Bits[11:9]

RES0.

POWERID, bits[8:4]

The power domain ID of the component. This field:

- Supports up to 32 power domains using values 0x00 to 0x1F.
- Is only valid if the POWERIDVALID field, which consists of bit[2] of the same ROMENTRY<n>, is 0b1, otherwise this field must be RES0.

Bit[3]

RES0.

POWERIDVALID, bit[2]

Indicates if the Power domain ID field contains a Power domain ID:

- 0b0 A power domain ID is not provided.
- 0b1 The POWERID field, which consists of bits[8:4] of the same ROMENTRY<n>, provides a power domain ID.

PRESENT, bits[1:0]

Indicates whether an entry is present at this location in the ROM Table. This field can have one of the following values:

0b00	The ROM entry is not present, and this ROMENTRY<n> is the final entry in the ROM Table. If PRESENT has this value, all other fields in this ROMENTRY<n> must be zero.
0b01	Reserved.
0b10	The ROM entry is not present, and this ROMENTRY<n> is not the final entry in a ROM Table with fewer than the maximum number of entries. If PRESENT has this value, all other fields in this entry are UNKNOWN.
0b11	The ROM Entry is present.

If the number of components is equal to the maximum number of ROM Table entries, the last ROM Table entry is not required to have a PRESENT field with the value 0b00.

Accessing the ROMENTRY<n>

The [ROMENTRY<n>](#) for component *n* can be accessed at the following address:

Component	Offset	
	DEVID.FORMAT == 0x0	DEVID.FORMAT == 0x1
ROM Table	0x000+n×4	0x000+n×8

D3.5.18 SYSPCR<n>, Debug Power Control Registers

The [SYSPCR<n>](#) characteristics are:

Purpose

Power request version 0 supports up to 32 system power domains, with separate registers for each domain providing controls for power requests.

The register that controls power requests for system power domain *n* is [SYSPCR<n>](#). [SYSPCR<n>](#) is used for the following purposes:

- To indicate whether a power request mechanism is implemented for system power domain *n*.
- To request power to system power domain *n*.

Usage constraints

System power requests might be ignored in certain scenarios. For more information, see [System power requests on page D3-323](#).

The [SYSPCR<n>](#) are accessible as follows:

Default

RW

Configurations

Only implemented if [PRIDR0.VERSION](#) indicates it is implemented.

Attributes

Up to 32 32-bit registers.

Field Descriptions

The `SYSPCR<n>` bit assignments are:

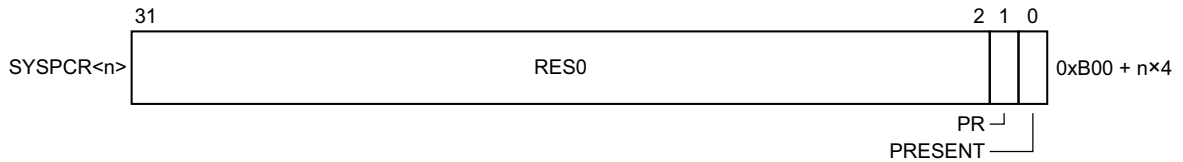

Bits[31:2]

RES0.

PR, bit[1]

Power request. This field can have one of the following values:

- 0b0 Power is not requested for system power domain *n*.
- 0b1 Power is requested for system power domain *n*.

This field is reserved if power requests are not implemented for system power domain *n*, which is the case if `SYSPCR<n>.PRESENT` has the value 0b0.

PRESENT, bit[0]

This RO field indicates whether the power request for system power domain *n* is implemented. PRESENT can have one of the following values:

- 0b0 Power request for system power domain *n* is not implemented.
- 0b1 Power request for system power domain *n* is implemented, and therefore `SYSPCR<n>.PR` and `SYSPSR<n>` are also implemented.

Accessing the SYSPCR<n>

The `SYSPCR<n>` for system power domain *n* can be accessed at the following address:

Component	Offset
ROM Table	<code>0xB00+n*4</code>

D3.5.19 SYSPSR<n>, System Power Status Registers

The `SYSPSR<n>` characteristics are:

Purpose

Power request version 0 supports up to 32 system power domains, with separate registers for each domain providing controls for power requests.

The register that indicates the current power status for system power domain *n* is `SYSPSR<n>`.

Usage constraints

`SYSPSR<n>` registers are accessible as follows:

Default
RO

Configurations

Only implemented if `SYSPCR<n>.PRESENT` is 1.

Attributes

Up to 32 32-bit registers.

Field Descriptions

The `SYSPSR<n>` bit assignments are:



Bits[31:2]

RES0.

PS, bits[1:0]

Power status of system power domain n . This field can have one of the following values:

- 0b00 System power domain n might not be powered.
- 0b01 System power domain n is powered.
- 0b10 Reserved.
- 0b11 System power domain n is powered and must remain powered until `SYSPCR<n>.PR` is set to 0b0.

An implementation of the power request mechanism is not expected to be capable of indicating both the 0b01 and 0b11 values of `SYSPSR<n>.PS`.

- When `SYSPSR<n>.PS` reads as 0b01, power is applied to system power domain n . If `SYSPCR<n>.PR` is 0b1, Arm recommends that power to system power domain n is continually maintained until `SYSPCR<n>.PR` is set to 0b0, to ensure that system-related programmed state is not lost during a debug session.
- When `SYSPSR<n>.PS` can read as 0b11, the four-phase handshake with `SYSPCR<n>.PR`, shown in Figure D3-10, guarantees that system power domain n is powered when required.

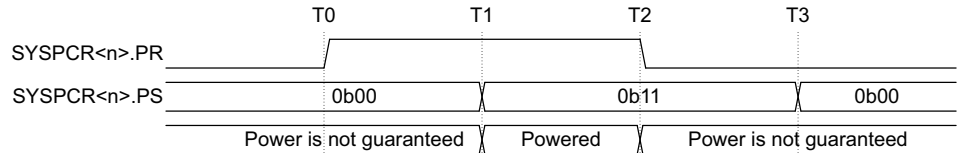

Figure D3-10 Power handshake

The steps in Figure D3-10 are:

- At T0, `SYSPCR<n>.PR` is written with 0b1 to request power.
- At T1, `SYSPSR<n>.PS` is set to 0b11 to indicate that the power request has been seen and power has been provided and is maintained.
- At T2, `SYSPCR<n>.PR` is written with 0b0 to clear the power request.
- At T3, `SYSPSR<n>.PS` is cleared to 0b00 to acknowledge that the power request has been removed.

Between T1 and T2, power must be supplied to power domain n , and must not be removed. If T1 is never reached because the system cannot power up the domain, `SYSPSR<n>.PS` must remain 0b00. The debugger might choose to remove the power request by writing 0b0 to `SYSPCR<n>.PR`, although this practice is not recommended.

`SYSPCR<n>.PR` must not be used to initiate a power request when `SYSPSR<n>.PS` reads as 0b11, because this value indicates that the handshake from a previous request is still completing.

Accessing the SYSPSR<n>

The SYSPSR<n> for system power domain *n* can be accessed at the following address:

Component	Offset
ROM Table	0xB80+n×4

D3.5.20 SYRSTAR, System Reset Acknowledge Register

The SYRSTAR characteristics are:

Purpose

Used to indicate that a system reset has been completed, as an acknowledgment to a request that was made by using SYRSTRR.

Usage constraints

SYRSTAR is accessible as follows:

Default
RO

Configurations

PRIDR0.SYSRR indicates whether this register is implemented.

Attributes

A 32-bit register.

Field Descriptions

The SYRSTAR bit assignments are:

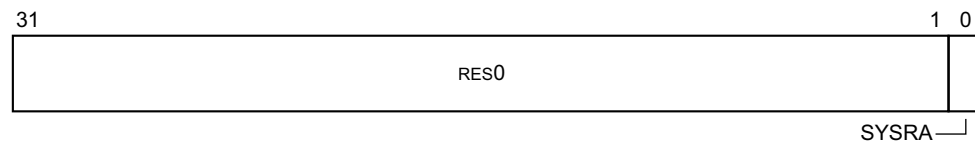

Bits[31:1]

RES0.

SYSRA, bit[0]

System Reset Acknowledge:

0b0 The system reset request has not initiated, or has been completed in response to SYRSTRR.SYSRR being deasserted.

0b1 The system reset request has been initiated.

After a power-on reset, this field is set to 0b0.

Accessing SYSRSTAR

[SYSRSTAR](#) can be accessed at the following address:

Component	Offset
ROM Table	0xC1C

D3.5.21 SYSRSTRR, System Reset Request Register

The [SYSRSTRR](#) characteristics are:

Purpose

[SYSRSTRR](#) is used to request a reset of the entire system or subsystem. The scope of this reset is IMPLEMENTATION DEFINED.

[SYSRSTRR](#) is used with [SYSRSTAR](#) in a handshake mechanism that indicates when a reset has been completed.

Usage constraints

System reset requests can be ignored in certain scenarios. See [System reset control on page D3-326](#).

When system reset requests are ignored, then it is IMPLEMENTATION DEFINED whether writes to [SYSRSTRR](#) are also ignored.

[SYSRSTRR](#) is accessible as follows:

Default
RW

Configurations

[PRIDR0.SYSRR](#) indicates whether this register is implemented.

Attributes

A 32-bit register.

Field Descriptions

The [SYSRSTRR](#) bit assignments are:

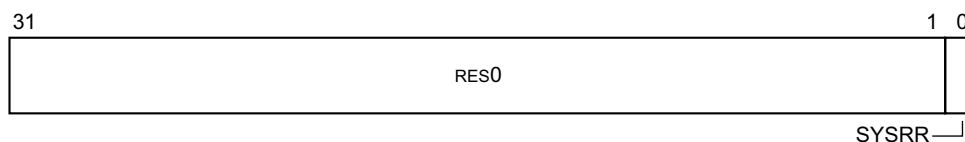

Bits[31:1]

RES0.

SYSRR, bit[0]

System Reset Request:

0b0 A system reset is not requested.

0b1 A system reset is requested. The request remains asserted until this field is explicitly overwritten with the value 0b0.

After a power-on reset, this field is set to 0b0.

Accessing SYSRSTR

[SYSRSTR](#) can be accessed at the following address:

Component	Offset
ROM Table	0xC18

Part E

Appendixes

Appendix E1

Standard Memory Access Port Definitions

This appendix provides information on implementing the Memory Access Port (MEM-AP). It contains the following sections:

- [Introduction](#) on page E1-360.
- [AMBA AXI3 and AXI4](#) on page E1-361.
- [AMBA AXI4 with ACE-Lite](#) on page E1-363.
- [AMBA AXI5](#) on page E1-366.
- [AMBA AHB3](#) on page E1-370.
- [AMBA AHB5](#) on page E1-373.
- [AMBA AHB5 with enhanced HPROT control](#) on page E1-375.
- [AMBA APB2 and APB3](#) on page E1-377.

E1.1 Introduction

The *Memory Access Port* (MEM-AP) programmers' model includes IMPLEMENTATION DEFINED features. This appendix provides reference implementation options for implementers and users of MEM-APs when connecting to standard memory interfaces. In particular, it provides the recommended interpretations of the following fields:

- [CSW.Prot.](#)
- [CSW.SDeviceEn.](#)

———— **Note** —————

CSW.SDeviceEn uses the same position as CSW.SPIDEN in ADIV5 and before, and has the same meaning. The field name is changed from SPIDEN to SDeviceEn to avoid confusing the field with the **SPIDEN** signal on the authentication interface.

- [CSW.Type.](#)
- [CSW.AddrInc.](#)
- [CSW.Size.](#)

E1.2 AMBA AXI3 and AXI4

This section describes the implementation of the **CSW** register for AMBA AXI3 and AXI4 implementations. For more information, see *AMBA® AXI™ and ACE™ Protocol Specification AXI3™, AXI4™, and AXI4-Lite™, ACE and ACE-Lite™*.

E1.2.1 CSW register implementation

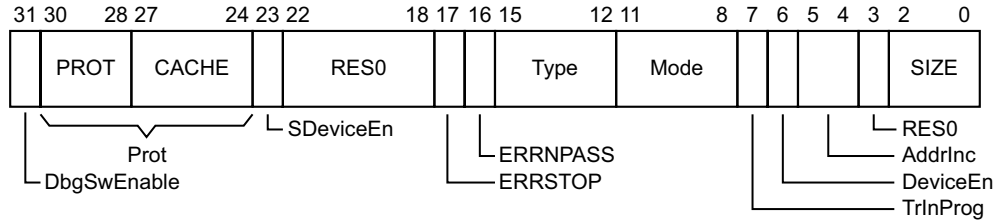

DbgSwEnable, bit[31]

See *CSW, Control/Status Word register* on page C2-216.

Prot, bits[30:24]

For reads, the **CSW.Prot** field drives the AXI **ARCACHE** and **ARPROT** signals.
For writes, the **CSW.Prot** field drives the AXI **AWCACHE** and **AWPROT** signals.
The settings for the **CSW.Prot** field are:

PROT[2:0], bits[30:28]

Drives **AxPROT[2:0]**, where **x** is **R** for reads and **W** for writes, see [Table E1-1](#).

Table E1-1 CSW.Prot mapping to ARPROT or AWPROT

Bit	ARPROT signal	AWPROT signal	Description
30	ARPROT[2]	AWPROT[2]	Instruction
29	ARPROT[1]	AWPROT[1]	Non-secure
28	ARPROT[0]	AWPROT[0]	Privileged

CSW.Prot[29], Non-secure, specifies a non-secure transfer. Its behavior depends on the value of **CSW.SDeviceEn**. For values in **CSW.Prot[29]**:

- 0b1 Non-secure transfer requested. **ARPROT[1]** or **AWPROT[1]** is HIGH.
- 0b0 Secure transfer requested. If **CSW.SDeviceEn** is 0b1, **ARPROT[1]** or **AWPROT[1]** is LOW. If **CSW.SDeviceEn** is 0b0, no transfer is initiated, and Arm recommends that an error response is returned to the DP if an access is made to the **DRW** or Banked Data registers.

CACHE[3:0], bits[27:24]

Drives **AxCACHE[3:0]**, where **x** is **R** for reads and **W** for writes, see [Table E1-2](#).

Table E1-2 CSW.Prot mapping to ARCACHE or AWCACHE

Bit	ARCACHE signal	AWCACHE signal
27	ARCACHE[3]	AWCACHE[3]
26	ARCACHE[2]	AWCACHE[2]
25	ARCACHE[1]	AWCACHE[1]
24	ARCACHE[0]	AWCACHE[0]

Note

AMBA AXI4 requires asymmetrical usage of **ARCACHE** and **AWCACHE**.

The reset value of **CSW.Prot** is 0b0110000.

SDeviceEn, bit[23]

The **CSW.SDeviceEn** bit reflects the state of the CoreSight authentication signal, **SPIDEN**.

Bits[22:18]

RES0.

ERRSTOP, bit[17]

See *CSW, Control/Status Word register* on page C2-216.

ERRNPASS, bit[16]

See *CSW, Control/Status Word register* on page C2-216.

Type, bits[15:12]

RES0.

Mode, bits[11:8]

RES0.

TrInProg, bit[7]

See *CSW, Control/Status Word register* on page C2-216.

DeviceEn, bit[6]

See *CSW, Control/Status Word register* on page C2-216.

AddrInc, bits[5:4]

CSW.AddrInc supports the *Increment Packed* mode of transfer. See *Packed transfers* on page C2-187.

Bit[3]

RES0.

Size, bits[2:0]

CSW.Size must support word, half-word, and byte size accesses. It is IMPLEMENTATION DEFINED whether larger access sizes are supported.

E1.3 AMBA AXI4 with ACE-Lite

This section describes the register implementation for AMBA AXI4 implementations with ACE-Lite. For more information, see the *AMBA® AXI™ and ACE™ Protocol Specification AXI3™, AXI4™, and AXI4-Lite™, ACE and ACE-Lite™*.

The following registers are covered:

- [CSW register implementation.](#)
- [MBT register implementation on page E1-365.](#)

E1.3.1 CSW register implementation

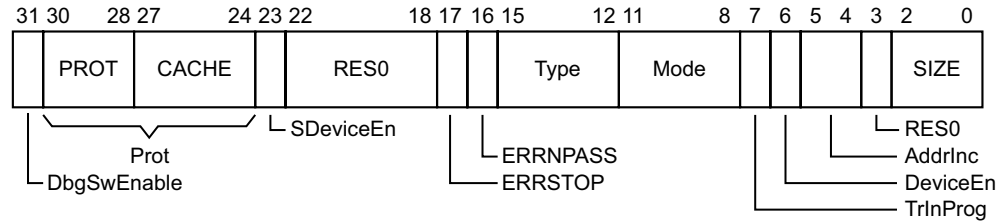

DbgSwEnable, bit[31]

See [CSW, Control/Status Word register on page C2-216](#).

Prot, bits[30:24]

For reads, the `CSW.Prot` field drives the AXI **ARCACHE** and **ARPROT** signals.
For writes, the `CSW.Prot` field drives the AXI **AWCACHE** and **AWPROT** signals.

The settings for the `CSW.Prot` field are:

PROT[2:0], bits[30:28]

Drives `AxPROT[2:0]`, where x is **R** for reads and **W** for writes, see [Table E1-3](#).

Table E1-3 CSW.Prot mapping to ARPROT or AWPROT

Bit	ARPROT signal	AWPROT signal	Description
30	ARPROT[2]	AWPROT[2]	Instruction
29	ARPROT[1]	AWPROT[1]	Non-secure
28	ARPROT[0]	AWPROT[0]	Privileged

`CSW.Prot[29]`, Non-secure, specifies a non-secure transfer. Its behavior depends on the value of `CSW.SDeviceEn`. For values in `CSW.Prot[29]`:

- 0b1 Non-secure transfer requested. **ARPROT[1]** or **AWPROT[1]** is HIGH.
- 0b0 Secure transfer requested. If `CSW.SDeviceEn` is 0b1, **ARPROT[1]** or **AWPROT[1]** is LOW. If `CSW.SDeviceEn` is 0b0, no transfer is initiated, and Arm recommends that an error response is returned to the DP if an access is made to the **DRW** or Banked Data registers.

CACHE[3:0], bits[27:24]

Drives **AxCACHE[3:0]**, where **x** is **R** for reads and **W** for writes, see [Table E1-4](#).

Table E1-4 CSW.Prot mapping to ARCACHE or AWCACHE

Bit	ARCACHE signal	AWCACHE signal
27	ARCACHE[3]	AWCACHE[3]
26	ARCACHE[2]	AWCACHE[2]
25	ARCACHE[1]	AWCACHE[1]
24	ARCACHE[0]	AWCACHE[0]

Note

AMBA AXI4 requires asymmetrical usage of **ARCACHE** and **AWCACHE**.

The reset value of **CSW.Prot** is **0b0110000**.

SDeviceEn, bit[23]

The **CSW.SDeviceEn** bit reflects the state of the CoreSight authentication signal, **SPIDEN**.

Bits[22:18]

RES0.

ERRSTOP, bit[17]

See *CSW, Control/Status Word register* on page C2-216.

ERRNPASS, bit[16]

See *CSW, Control/Status Word register* on page C2-216.

Type, bits[15:12]

The **CSW.Type** field drives the AXI **AxDOMAIN** signals, where **x** is **R** for reads and **W** for writes.

The settings for the **CSW.Type** bit field are:

bit[15] Reserved, RES0.

DOMAIN[1:0], bits[14:13]

Possible values are:

- 0b00 Non-shareable.
- 0b01 Inner shareable.
- 0b10 Outer shareable.
- 0b11 System.

The reset value of this field is **0b11**.

EnMBT, bit[12]

Enable MBT accesses.

It is IMPLEMENTATION DEFINED whether this field is RW or RAO. If it is RW, the reset value is **0b0**, and must be set to **0b1** before writing to the **MBT** register.

Mode, bits[11:8]

It is IMPLEMENTATION DEFINED whether this field is RW or RO. If it is RW, the reset value is **0b0000**, and must be set to **0b0001** before writing to the **MBT** register. If it is RO, then it has the fixed value **0b0001**.

TrInProg, bit[7]

See *CSW, Control/Status Word register* on page C2-216.

DeviceEn, bit[6]

See *CSW, Control/Status Word register* on page C2-216.

AddrInc, bits[5:4]

CSW.AddrInc supports the *Increment Packed* mode of transfer. See *Packed transfers* on page C2-187.

Bit[3]

RES0.

Size, bits[2:0]

CSW.Size must support word, half-word, and byte size accesses. It is IMPLEMENTATION DEFINED whether larger access sizes are supported.

E1.3.2 MBT register implementation

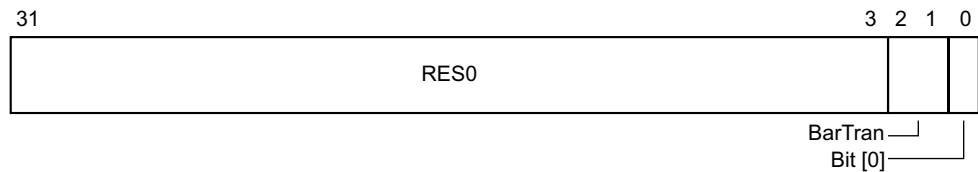

Attributes

MBT register is a read/write register.

Bits[31:3]

Reserved, RES0.

BarTran, bits[2:1]

Possible values are:

- 0b00 Reserved
- 0b01 Memory barrier
- 0b10 Reserved
- 0b11 Synchronization barrier.

Bit[0]

On reads:

- 0b0 Barrier transaction in progress.
- 0b1 No barrier transaction in progress.

SBO on writes.

E1.4 AMBA AXI5

This section describes the register implementation for AMBA AXI5 implementations. For more information, see the *AMBA® AXI™ and ACE™ Protocol Specification AXI5 and AXI5-Lite*.

The following registers are covered:

- [CSW register implementation on page E1-363](#).

Support for the Memory Tagging Extension in an AXI5 MEM-AP is optional. When the Memory Tagging Extension is implemented:

- The MEM-AP implements the Large Data Extension, supporting access sizes of up to at least 64-bits.
- The MEM-AP implements the Memory Tagging Extension, supporting 4-bit tags with a 16-byte memory tagging granule.

When memory tagging is enabled, the data size selected by [CSW.SIZE](#) must be one of:

- 64-bits.
- An integer multiple of 128-bits.

———— **Note** ————

This specification permits a MEM-AP with memory tagging to only support data value sizes up to 64 bits. However AXI5 does require a bus width of 128-bit and any AXI-AP design needs to ensure it implements the requirements of both specifications.

System memory read accesses with memory tagging enabled perform AXI *Transfer* tag operations on **ARTAGOP**.

System memory write accesses with memory tagging enabled perform AXI *Update* tag operations on **AWTAGOP**.

———— **Note** ————

AXI-AP has no need for the *Transfer* or *Match* tag operations on **AWTAGOP**.

When a 64-bit system memory read access is initiated, the AXI-AP performs a read transaction of at least 128-bits, and discards the unused data bytes.

When a 64-bit system memory write access is initiated, the AXI-AP performs a write transaction of at least 128-bits, and drives the write strobes appropriately to ensure only the correct 64-bits of data are transferred.

When the Realm Management Extension is implemented, [CSW.NSE](#) is present and is used with [CSW.PROT\[1\]](#) to select the physical address (PA) space of the memory access.

[CSW.NSE](#) and [CSW.PROT\[1\]](#) define the PA space of the memory access. [Table E1-5](#) and [Table E1-6](#) on [page E1-367](#) illustrate the PA space definitions of PA space memory access.

Table E1-5 AXI-AP PA space selection, when Realm Management Extension is not implemented

CSW.PROT[1]	Selected PA space
0b0	Secure
0b1	Non-secure

Table E1-6 AXI-AP PA space selection, when Realm Management Extension is implemented

CSW.NSE	CSW.PROT[1]	Selected PA space
0b0	0b0	Secure
0b0	0b1	Non-secure
0b1	0b0	Root
0b1	0b1	Realm

If **CSW.NSE** and **CSW.PROT[1]** select a PA space for a location where a memory access is not permitted, no memory access is performed.

Note

The NSE and PROT values in [Table E1-6](#) mean that a legacy (before Realm Management Extension) debugger attempting to access memory allocated to EL3 in a Realm Management Extension-enabled system will not access the Root PA space but instead will access Secure memory.

Support for the Memory Encryption Contexts extension (MEC Extension) in an AXI5 MEM-AP is IMPLEMENTATION DEFINED, even in systems that support FEAT_MEC. Arm recommends that a MEM-AP supports the MEC Extension if it is connected to a memory system that supports FEAT_MEC.

E1.4.1 CSW register implementation

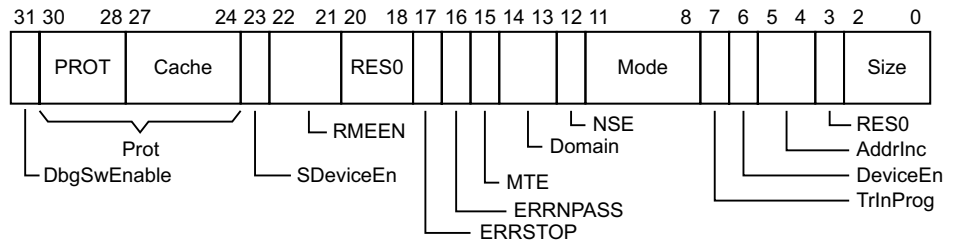

DbgSwEnable, bit[31]

See *CSW, Control/Status Word register* on page C2-216.

Prot, bits[30:24]

For reads, the **CSW.Prot** field drives the AXI **ARCACHE** and **ARPROT** signals.
For writes, the **CSW.Prot** field drives the AXI **AWCACHE** and **AWPROT** signals.

The settings for the **CSW.Prot** field are:

PROT[2:0], bits[30:28]

Drives **AxPROT[2:0]**, where x is **R** for reads and **W** for writes, see [Table E1-3](#) on page E1-363.

Table E1-7 CSW.Prot mapping to ARPROT or AWPROT

Bit	ARPROT signal	AWPROT signal	Description
30	ARPROT[2]	AWPROT[2]	Instruction
29	ARPROT[1]	AWPROT[1]	Non-secure
28	ARPROT[0]	AWPROT[0]	Privileged

CSW.Prot[29], Non-secure, specifies a non-secure transfer. Its behavior depends on the value of **CSW.SDeviceEn**. For values in **CSW.Prot[29]**:

- 0b1 Non-secure transfer requested. **ARPROT[1]** or **AWPROT[1]** is HIGH.
- 0b0 Secure transfer requested. If **CSW.SDeviceEn** is 0b1, **ARPROT[1]** or **AWPROT[1]** is LOW. If **CSW.SDeviceEn** is 0b0, no transfer is initiated, and Arm recommends that an error response is returned to the DP if an access is made to the **DRW** or Banked Data registers.

CACHE[3:0], bits[27:24]

Drives **AxCACHE[3:0]**, where **x** is **R** for reads and **W** for writes, see [Table E1-4 on page E1-364](#).

Table E1-8 CSW.Prot mapping to ARCACHE or AWCACHE

Bit	ARCACHE signal	AWCACHE signal
27	ARCACHE[3]	AWCACHE[3]
26	ARCACHE[2]	AWCACHE[2]
25	ARCACHE[1]	AWCACHE[1]
24	ARCACHE[0]	AWCACHE[0]

Note

AMBA AXI5 requires asymmetrical usage of **ARCACHE** and **AWCACHE**.

The reset value of **CSW.Prot** is 0b0110000.

SDeviceEn, bit[23]

The **CSW.SDeviceEn** bit reflects the state of the CoreSight authentication signal, **SPIDEN**.

RMEEN, bits [22:21]

Realm and Root access status.

When **CFG.RME** == 0b1

The defined values of this field are:

- 0b00 Realm and Root accesses are disabled
- 0b01 Realm access is enabled. Root access is disabled.
- 0b11 Realm access is enabled. Root access is enabled.

Otherwise

Reserved. This field is RES0.

All other values are reserved.

This field is read-only.

Bits[20:18]

RES0.

ERRSTOP, bit[17]

See *CSW, Control/Status Word register* on page C2-216.

ERRNPASS, bit[16]

See *CSW, Control/Status Word register* on page C2-216.

MTE, bit[15]

Memory Tagging control. The possible values of this bit are:

- 0b0 Memory tagging accesses disabled.
- 0b1 Memory tagging accesses enabled.

When memory tagging accesses are enabled, system read and write accesses via DRW, BDx, and DARx, use T0TR for transferring tag information.

When the Memory Tagging Extension is not implemented, this field is RES0.

Domain, bits[14:13]

The CSW.Type field drives the AXI AxDOMAIN signals, where x is **R** for reads and **W** for writes.

The settings for the CSW.Type bit field are:

DOMAIN[1:0], bits[14:13]

Possible values are:

- 0b00 Non-shareable.
- 0b01 Inner shareable.
- 0b10 Outer shareable.
- 0b11 System.

The reset value of this field is 0b11.

NSE, bit[12]

AxNSE value.

When CFG.RME == 0b1

Defines the PA space used for each memory access. Used in conjunction with PROT[1]. See *AMBA AXI5* on page E1-366.

Otherwise

Reserved. This field is RES0.

Bits[11:8]

RES0.

TrInProg, bit[7]

See *CSW, Control/Status Word register* on page C2-216.

DeviceEn, bit[6]

See *CSW, Control/Status Word register* on page C2-216.

AddrInc, bits[5:4]

CSW.AddrInc supports the *Increment Packed* mode of transfer. See *Packed transfers* on page C2-187.

Bit[3]

RES0.

Size, bits[2:0]

CSW.Size must support word, half-word, and byte size accesses. It is IMPLEMENTATION DEFINED whether larger access sizes are supported.

E1.5 AMBA AHB3

This section describes the implementation of the **CSW** register for AMBA AHB3 implementations. For more information, see the *AMBA® Specification (Rev 2.0)* and the *AMBA® 3 AHB-Lite™ Protocol Specification*.

E1.5.1 CSW register implementation

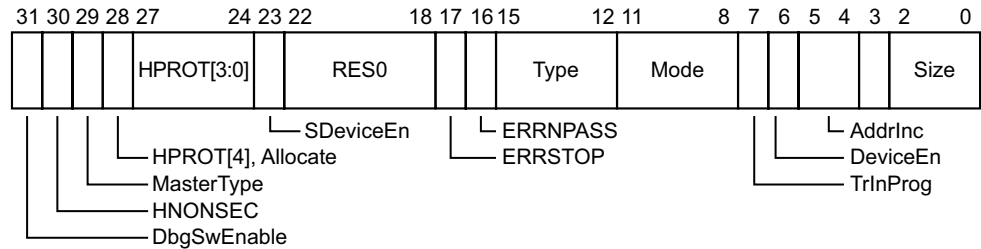

DbgSwEnable, bit[31]

See *CSW, Control/Status Word register* on page C2-216.

Prot, bits[30:24]

The **CSW.Prot** field drives the AHB **HPROT** signals. The settings for the **CSW.Prot** field are:

HNONSEC, bit[30]

Drives the value of an IMPLEMENTATION DEFINED **HNONSEC** signal.

HNONSEC is not a formally defined AHB3 signal.

If implemented, the reset value of this field is **0b1**.

If not implemented, this field is **SBO**, and if set to **0b0** the behavior of an AHB-AP transaction is UNPREDICTABLE.

MasterType, bit[29]

Master Type bit. **MasterType** permits the AHB-AP to mimic a second AHB Requester by driving a different value on **HMASTER[3:0]**. Support for this function is IMPLEMENTATION DEFINED. Valid values for this bit are:

0b1 Drive **HMASTER[3:0]** with the bus transaction Requester ID for the AHB-AP.

0b0 Drive **HMASTER[3:0]** with the bus transaction Requester ID for the second bus transaction Requester.

HPROT[4], Allocate, bit[28]

Drives **HPROT[4], Allocate**. **HPROT[4]** is an Armv5 extension to AHB. For more information, see the *Arm1136JF-S™ and Arm1136J-S™ Technical Reference Manual*.

If the AHB Requester interface does not support the Armv5 extension to AHB, this bit is **RAZ/WI**.

HPROT[3:0], bits[27:24]

Drives **HPROT[3:0]**. See [Table E1-9 on page E1-359](#). Support for each **HPROT** signal in the AHB Requester interface is IMPLEMENTATION DEFINED.

Table E1-9 CSW.Prot mapping

Bit	HPROT signal	Description	Description when not implemented at the AHB Requester interface
27	HPROT[3]	Cacheable	RAZ/WI
26	HPROT[2]	Bufferable	RAZ/WI
25	HPROT[1]	Privileged	RAO/WI
24	HPROT[0]	Data	RAO/WI

The reset value of **CSW.Prot** is 0b1000011.

SDeviceEn, bit[23]

It is IMPLEMENTATION DEFINED whether the **CSW.SDeviceEn** bit reflects the state of the CoreSight authentication signal, **SPIDEN**. Otherwise, the **CSW.SDeviceEn** bit is RAZ.

This bit is always read-only.

———— **Note** —————

AMBA AHB3 does not support Security Extensions.

Bits[22:18]

RES0.

ERRSTOP, bit[17]

See [CSW, Control/Status Word register on page C2-216](#).

ERRNPASS, bit[16]

See [CSW, Control/Status Word register on page C2-216](#).

Type, bits[15:12]

RES0.

Mode, bits[11:8]

RES0.

TrInProg, bit[7]

See [CSW, Control/Status Word register on page C2-216](#).

DeviceEn, bit[6]

See [CSW, Control/Status Word register on page C2-216](#).

AddrInc, bits[5:4]

Support for the *Increment Packed* mode of transfer is IMPLEMENTATION DEFINED. See [Packed transfers on page C2-187](#).

Bit[3]

RES0.

Size, bits[2:0]

CSW.Size must support word, half-word, and byte size accesses.

E1.6 AMBA AHB5

This section describes the implementation of the [CSW](#) register for AMBA AHB implementations. For more information, see the *AMBA® Specification (Rev 2.0)* and the *Arm® AMBA® 5 AHB Protocol Specification*.

The AHB-AP does not support the Realm Management Extension.

E1.6.1 CSW register implementation

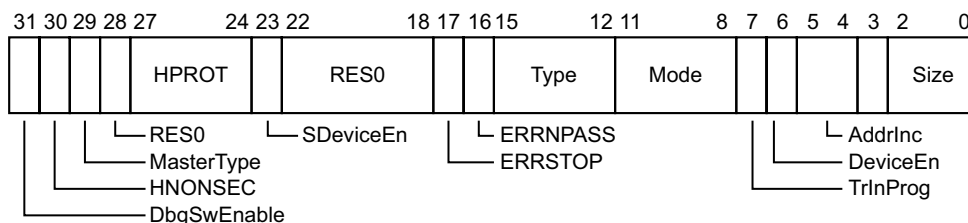

DbgSwEnable, bit[31]

See *CSW, Control/Status Word register* on page C2-216.

HNONSEC, Bit[30]

Drives the value of HNONSEC. It is IMPLEMENTATION DEFINED whether the HNONSEC field is supported.

If implemented, the reset value of this field is 0b1.

MasterType, bit[29]

Master Type field. MasterType permits the AHB-AP to mimic a second AHB Requester by driving a different value on **HMASTER[3:0]**. Support for this function is IMPLEMENTATION DEFINED. Valid values for this field are:

- 0b1 Drive **HMASTER[3:0]** with the bus transaction Requester ID for the AHB-AP.
- 0b0 Drive **HMASTER[3:0]** with the bus transaction Requester ID for the second bus transaction Requester.

If this function is not implemented, the field is RES0.

Bit[28]

RES0.

HPROT, bits[27:24]

Drives the value of **HPROT[6:0]**:

- Support for each **HPROT** signal is IMPLEMENTATION DEFINED.
- **HPROT[5]** is always driven with the value 0.
- Bit[27] drives **HPROT[6]**, **HPROT[4]**, and **HPROT[3]**.
- Bit[26] drives **HPROT[2]**.
- Bit[25] drives **HPROT[1]**.
- Bit[24] drives **HPROT[0]**.

SDeviceEn, bit[23]

It is IMPLEMENTATION DEFINED whether the SDeviceEn field reflects the state of the CoreSight authentication interface. If Secure debug is not supported, the CSW.SDeviceEn bit is RES0.

This field is always read-only.

Bits[22:18]

RES0.

ERRSTOP, bit[17]

See *CSW, Control/Status Word register* on page C2-216.

ERRNPASS, bit[16]

See *CSW, Control/Status Word register* on page C2-216.

Type, bits[15:12]

RES0.

Mode, bits[11:8]

RES0.

TrInProg, bit[7]

See *CSW, Control/Status Word register* on page C2-216.

DeviceEn, bit[6]

See *CSW, Control/Status Word register* on page C2-216.

AddrInc, bits[5:4]

Support for the Increment Packed mode of transfer is IMPLEMENTATION DEFINED. See *Packed transfers* on page C2-187.

Bit[3]

RES0.

Size, bits[2:0]

CSW.Size must support word, half-word, and byte size accesses.

E1.7 AMBA AHB5 with enhanced HPROT control

This section describes the implementation of the **CSW** register for AMBA AHB with enhanced HPROT control implementations. For more information, see the *AMBA® Specification (Rev 2.0)* and the *Arm® AMBA® 5 AHB Protocol Specification*.

E1.7.1 CSW register implementation

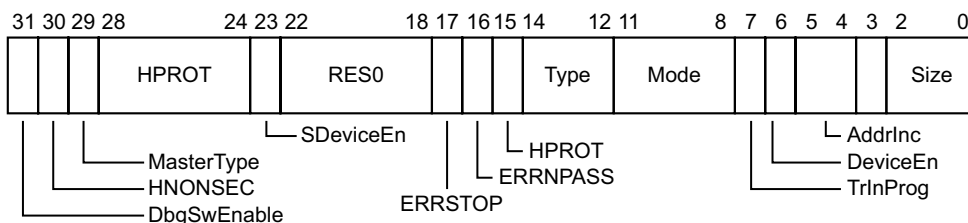

DbgSwEnable, bit[31]

See *CSW, Control/Status Word register* on page C2-216.

HNONSEC, bit[30]

Drives the value of HNONSEC. It is IMPLEMENTATION DEFINED whether the HNONSEC field is supported.

If implemented, the reset value of this field is 0b1.

MasterType, bit[29]

Master Type field. MasterType permits the AHB-AP to mimic a second AHB Requester by driving a different value on **HMASTER[3:0]**. Support for this function is IMPLEMENTATION DEFINED. Valid values for this field are:

- 0b1 Drive **HMASTER[3:0]** with the bus Requester ID for the AHB-AP.
- 0b0 Drive **HMASTER[3:0]** with the bus Requester ID for the second bus Requester.

If this function is not implemented, the field is RES0.

HPROT, bits[28:24, 15]

Bits[28:24] drive the value of **HPROT[6:0]**.

- Support for each **HPROT** signal is IMPLEMENTATION DEFINED.
- Bit[15] drives **HPROT[6]**.
- **HPROT[5]** is always driven with the value 0.
- Bits[28:24] drive **HPROT[4:0]**.

SDeviceEn, bit[23]

It is IMPLEMENTATION DEFINED whether the SDeviceEn field reflects the state of the CoreSight authentication interface. If Secure debug is not supported, the CSW.SDeviceEn bit is RES0.

This field is always read-only.

Bits[22:18]

RES0.

ERRSTOP, bit[17]

See *CSW, Control/Status Word register* on page C2-216.

ERRNPASS, bit[16]

See *CSW, Control/Status Word register* on page C2-216.

HPROT, bit[15]	Used to control HPROT , see the HPROT field.
Type, bits[14:12]	RES0.
Mode, bits[11:8]	RES0.
TrInProg, bit[7]	See <i>CSW, Control/Status Word register</i> on page C2-216.
DeviceEn, bit[6]	See <i>CSW, Control/Status Word register</i> on page C2-216.
AddrInc, bits[5:4]	Support for the Increment Packed mode of transfer is IMPLEMENTATION DEFINED. See <i>Packed transfers</i> on page C2-187.
Bit[3]	RES0.
Size, bits[2:0]	<i>CSW</i> .Size must support word, half-word, and byte size accesses.

E1.8 AMBA APB2 and APB3

This section describes the implementation of the CSW register for AMBA APB2 and APB3 implementations. For more information see the *AMBA® Specification (Rev 2.0)*, and the *AMBA® Protocol Specification Version: 2.0*.

E1.8.1 CSW register implementation

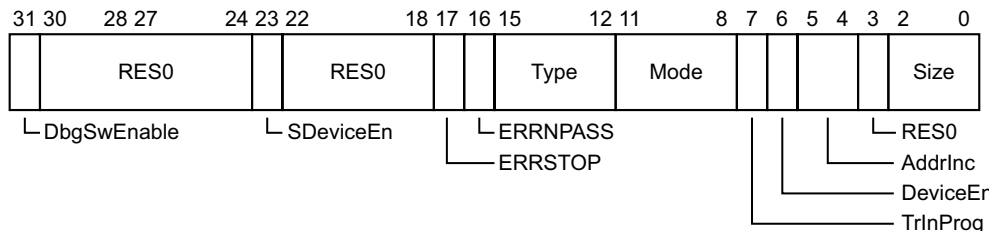

DbgSwEnable, bit[31]

See *CSW, Control/Status Word register* on page C2-216.

Prot, bits[30:24]

RES0.

SDeviceEn, bit[23]

RES0.

Bits[22:18]

RES0.

ERRSTOP, bit[17]

See *CSW, Control/Status Word register* on page C2-216

ERRNPASS, bit[16]

See *CSW, Control/Status Word register* on page C2-216

Type, bits[15:12]

RES0.

Mode, bits[11:8]

RES0.

TrInProg, bit[7]

See *CSW, Control/Status Word register* on page C2-216

DeviceEn, bit[6]

See *CSW, Control/Status Word register* on page C2-216

AddrInc, bits[5:4]

CSW.AddrInc does not support the *Increment Packed* mode of transfer, and reads as 0b00. See also *Packed transfers* on page C2-187.

Bit[3]

RES0.

Size, bits[2:0]

CSW.Size only supports word accesses, and reads as 0b010. Writes to CSW.Size are ignored.

E1.9 AMBA APB4 and APB5

This section describes the implementation of the **CSW** register for AMBA APB4 and APB5 implementations. For more information see the *AMBA® APB Protocol Specification*.

When the Realm Management Extension is implemented, **CSW.NSE** is present and is used with **CSW.PROT[1]** to select the PA space of the memory access.

CSW.NSE and **CSW.PROT[1]** define the PA space of the memory access. [Table E1-10](#) and [Table E1-11](#) on [page E1-378](#) illustrate the PA space definitions of PA space memory access.

Table E1-10 APB-AP PA space selection, when Realm Management Extension is not implemented

CSW.PROT[1]	Selected PA space
0b0	Secure
0b1	Non-secure

Table E1-11 APB-AP PA space selection, when Realm Management Extension is implemented

CSW.NSE	CSW.PROT[1]	Selected PA space
0b0	0b0	Secure
0b0	0b1	Non-secure
0b1	0b0	Root
0b1	0b1	Realm

If **CSW.NSE** and **CSW.PROT[1]** select a PA space for a location where a memory access is not permitted, no memory access is performed.

———— **Note** —————

The NSE and PROT values in [Table E1-11](#) mean that a legacy (before Realm Management Extension) debugger attempting to access memory allocated to EL3 in a Realm Management Extension-enabled system will not access the Root PA space but instead will access Secure memory.

E1.9.1 CSW register implementation

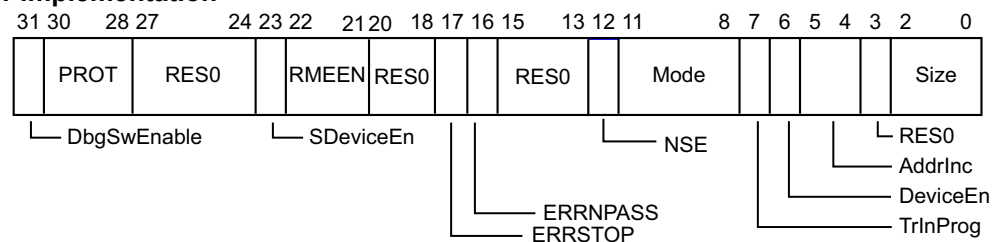

DbgSwEnable, bit[31]

See *CSW, Control/Status Word register* on [page C2-216](#).

Prot[2:0], bits[30:28]

Drives **PPROT[2:0]**.

Bit[29], Non-secure, corresponds to Prot[1], and specifies a non-secure transfer. This bit can have one of the following values:

0b1 Non-secure transfer requested. **PPROT[1]** is HIGH.

0b0 Secure transfer requested. The resulting behavior depends on the value of the [CSW.SDeviceEn](#) field:

- If [CSW.SDeviceEn](#) is 0b1, [PPROT\[1\]](#) is LOW.
- If [CSW.SDeviceEn](#) is 0b0, no transfer is initiated, and Arm recommends that, if an access is made to the [DRW](#), [DAR0-DAR255](#), or [BD0-BD3](#) registers, an error response is returned.

Bits[27:24]

RES0.

SDeviceEn, bit[23]

It is IMPLEMENTATION DEFINED whether [CSW.SDeviceEn](#) reflects the state of the CoreSight authentication interface. If Secure debug is not supported, [CSW.SDeviceEn](#) is RES0.

This field is always read-only.

RMEEN, bits [22:21]

Realm and Root access status.

When [CFG.RME](#) == 0b1

The defined values of this field are:

- 0b00 Realm and Root accesses are disabled.
- 0b01 Realm access is enabled. Root access is disabled.
- 0b11 Realm access is enabled. Root access is enabled.

Otherwise

Reserved. This field is RES0.

All other values are reserved.

This field is read-only.

Bits[20:18]

RES0.

ERRSTOP, bit[17]

See [CSW, Control/Status Word register on page C2-216](#)

ERRNPASS, bit[16]

See [CSW, Control/Status Word register on page C2-216](#)

Bits[15:13]

RES0.

NSE, bit[12]

PNSE value.

When [CFG.RME](#) == 0b1

Defines the PA space used for each memory access. Used in conjunction with [PROT\[1\]](#).

Otherwise

Reserved. This field is RES0.

Mode, bits[11:8]

RES0.

TrInProg, bit[7]

See [CSW, Control/Status Word register on page C2-216](#)

DeviceEn, bit[6]

See *CSW, Control/Status Word register* on page C2-216

AddrInc, bits[5:4]

CSW.AddrInc does not support the *Increment Packed* mode of transfer, and reads as 0b00. See also *Packed transfers* on page C2-187.

Bit[3]

RES0.

Size, bits[2:0]

CSW.Size only supports word accesses, and reads as 0b010. Writes to *CSW.Size* are ignored.

Appendix E2

Cross-over with the Arm Architecture

This appendix describes the required or recommended options for the Arm Debug Interface for the Armv6-M and all Armv7, Armv8, and Armv9 architecture profiles. It contains the following sections:

- *Introduction on page E2-382.*
- *Armv6-M, Armv7-M, and Armv8-M architecture profiles on page E2-383.*
- *PEs with a physical address up to 32 bits on page E2-384.*
- *PEs with a physical address greater than 32 bits on page E2-385.*
- *Summary of the requirements for ADIV6 implementations on page E2-386.*

E2.1 Introduction

The Arm Debug Interface v6 is the recommended external debug interface for Armv6-M, all Armv7, all Armv8, and Armv9 architecture profiles.

When designing with Arm Cortex™ processor cores and Arm CoreSight technology, the choice of *Arm Debug Interface* (ADI) features might be at the discretion of the system designer. Arm recommends that system designers choose an ADI that implements all the recommended features for each Arm architecture processing element (PE) that is contained in the design.

ADIV6 might also be used with other architecture variants. For example, an ADIV6 JTAG Access Port (JTAG-AP) might access a Debug Test Access Port (DBGTAP), as defined by Arm Debug Interface v4 (ADIV4) for Armv6 architecture processors.

E2.2 Armv6-M, Armv7-M, and Armv8-M architecture profiles

Arm recommends that an ADI that implements ADIV5 or later is used to access the debug features of the Armv6-M, Armv7-M, or Armv8-M architecture.

Arm recommends that the DP implements the SWD interface, either through an SW-DP or SWJ-DP. A JTAG-DP is permitted.

When accessing debug features of the Armv6-M architecture, or the Armv8-M architecture without the Main Extension, Arm recommends that the DP implements the MINDP model. See [MINDP, Minimal DP extension on page B1-42](#).

There must be one MEM-AP for each PE, which complies with the following rules:

- The MEM-AP must be able to address the complete memory space visible to the PE, including all debug peripherals and the NVIC.
- The MEM-AP must support byte, half-word, and word size accesses to memory.
- A MEM-AP that is used to access debug features of the Armv6-M architecture, or the Armv8-M architecture without the Main Extension, is not required to support the packed increment transfer mode.
- A MEM-AP that is used to access debug features of the Armv7-M architecture, or the Armv8-M architecture with the Main Extension, is permitted to support the packed increment transfer mode.

Other APs can be connected to the DP.

E2.3 PEs with a physical address up to 32 bits

The Armv7-A without the Large Physical Address Extension, Armv7-R, and Armv8-R AArch32 architecture profiles do not require compliance with ADIV5 or later. The Arm development tools, however, do require compliance with ADIV5 or later.

Where an ADI implementation that is compliant with ADIV5 or later is implemented, Arm recommends that the DP implements the JTAG and SWD interfaces through an SWJ-DP.

Many PEs can be connected to a single MEM-AP. The MEM-AP must only be able to address the debug peripherals of the connected PEs. If the MEM-AP can only address the debug peripherals, it is only required to support word size accesses to memory, and therefore is not required to support the packed increment transfer mode.

Arm recommends that debug implementations include a MEM-AP that can address the complete memory space visible to the PE or PEs. This MEM-AP might be a second MEM-AP that is connected to the DP. Arm recommends that a MEM-AP that can access the complete memory space supports byte, half-word, and word size accesses to memory. This MEM-AP is permitted to support the packed increment transfer mode.

Other APs can also be connected to the DP.

———— **Note** —————

Do not confuse the Armv7-A or Armv8-A Large Physical Address Extension with the MEM-AP Large Physical Address Extension.

—————

E2.4 PEs with a physical address greater than 32 bits

The requirements for Armv7-A with Large Physical Address Extension, Armv8-A, Armv8-R AArch64, and Armv9-A architecture profiles are the same as for [PEs with a physical address up to 32 bits on page E2-384](#), with the following additions for any MEM-AP with system access:

- MEM-AP Large Physical Address Extension, up to at least the size that is supported by the PE.
- For Armv7-A systems with the Large Physical Address Extension, Arm recommends that the MEM-AP implements the Large Data Extension providing at least doubleword accesses, to allow for atomic update of page table entries.
- For Armv8-A and Armv9-A systems, the MEM-AP must implement the Large Data Extension providing at least doubleword accesses.

E2.5 Summary of the requirements for ADiv6 implementations

Table E2-1 summarizes the required and recommended components of an ADI implementation for each of the Arm architecture variants for which ADiv6 is the required or recommended ADI.

Table E2-1 Recommended ADI implementations for Arm Architecture variants

Component		Armv6-M and Armv8-M without Main Extension	Armv7-M and Armv8-M with Main Extension	PEs with a physical address up to 32 bits	PEs with a physical address greater than 32 bits
DAP	ADiv5 or later	Required	Required	Recommended	Recommended
DP	JTAG-DP	Permitted	Permitted	Permitted	Permitted
	SW-DP	-	-	Permitted	Permitted
	SWJ-DP	-	-	Recommended	Recommended
	SWJ-DP or SW-DP	Recommended	Recommended	-	-
MEM-AP	One per PE	Required	Required	Permitted	Permitted
	Access to system memory	Required	Required	Permitted	Permitted
	Support for 8-bit and 16-bit accesses	Required	Required	Required only if system access is supported	Required only if system access is supported
	Support for 32-bit accesses	Required	Required	Required	Required
	Support for 64-bit accesses	Permitted	Permitted	Permitted	Required
	Support for large physical addresses	Not permitted	Not permitted	Permitted	Required if system access is supported
	Support for packed increment transfers	Permitted	Permitted	Permitted	Permitted
Support for the Memory Tagging Extension	Not permitted	Not permitted	Permitted	Required if system access is supported and system supports memory tagging.	

Appendix E3

Revisions

This appendix lists the technical changes between releases of this specification.

Table E3-1 First release of Version 6.0, Issue A

Location	Change
-	-

Table E3-2 Changes between Issues A and B

Location	Change
Chapter D3 Class 0x9 ROM Tables.	Additions to the Class 0x9 ROM table.
System and debug power control behavior on page B2-82.	Relaxed requirements for clocks to be running while CxxxPWRUPREQ is asserted, to require clocks to be available.
Parity on page B4-116.	Relaxed requirement to set CTRL/STAT.STICKYORUN if an SWD write data parity error occurs.

Table E3-3 Changes between Issues B and C

Location	Change
<i>AMBA AXI5</i> on page E1-366.	Added support for AXI5.
<i>AMBA AHB5</i> on page E1-373.	Added support for AHB5.
<i>MEM-AP Memory Tagging Extension</i> on page C2-194.	Added support for MTE.
<i>CFG1, Configuration register 1</i> on page C2-212.	
<i>T0TR, Tag 0 Transfer register</i> on page C2-239.	

Table E3-4 Changes between Issues C and D

Location	Change
Chapter C2 <i>The Memory Access Port</i> . Chapter D2 <i>Class 0x1 ROM Tables</i> . Chapter D3 <i>Class 0x9 ROM Tables</i> . <i>AMBA AXI5</i> on page E1-366. <i>AMBA APB4 and APB5</i> on page E1-378.	Added support for Realm Management Extension, affecting Generic MEM-AP, AXI-AP, and APB-AP.

Table E3-5 Changes between Issues D and E

Location	Change
Chapter C2 <i>The Memory Access Port</i> . <i>AMBA AXI5</i> on page E1-366.	Added support for the Memory Encryption Contexts (MEC) extension, affecting Generic MEM-AP and AXI-AP.

Glossary

This glossary describes some of the terms that are used in Arm documentation.

Abort

An abort occurs when an illegal memory access causes an exception. An abort can be generated by the hardware that manages memory accesses, or by the external memory system.

ADI

See [Arm Debug Interface \(ADI\)](#).

AHB

An AMBA bus protocol supporting pipelined operation, with the address and data phases occurring during different clock periods, meaning that the address phase of a transfer can occur during the data phase of the previous transfer. AHB provides a subset of the functionality of the AMBA AXI protocol.

See also [AMBA](#).

Aligned

A data item stored at an address that is exactly divisible by the number of bytes that defines its data size. Aligned doublewords, words, and halfwords have addresses that are divisible by eight, four, and two respectively. An aligned access is one where the address of the access is aligned to the size of each element of the access.

AMBA

The AMBA family of protocol specifications is the Arm open standard for on-chip buses. AMBA provides solutions for the interconnection and management of the functional blocks that make up a *System-on-Chip* (SoC). Applications include the development of embedded systems with one or more processors or signal processors and multiple peripherals.

APB

An AMBA bus protocol for ancillary or general-purpose peripherals such as timers, interrupt controllers, UARTs, and I/O ports. It connects to the main system bus through a system-to-peripheral bus bridge that helps reduce system power consumption.

Arm Debug Interface (ADI)

The ADI connects a debugger to a device. The ADI is used to access memory-mapped components in a system, such as processors and CoreSight components. The ADI protocol defines the physical wire protocols permitted, and the logical programmers model.

AXI

An AMBA bus protocol that supports:

- Separate phases for address or control and data.
- Unaligned data transfers using byte strobes.
- Burst-based transactions with only start address issued.
- Separate read and write data channels.
- Issuing multiple outstanding addresses.
- Out-of-order transaction completion.
- Optional addition of register stages to meet timing or repropagation requirements.

The AXI protocol includes optional signaling extensions for low-power operation.

Big-endian

In the context of the Arm architecture, big-endian is defined as the memory organization in which the least significant byte of a word is at a higher address than the most significant byte, for example:

- A byte or halfword at a word-aligned address is the most significant byte or halfword in the word at that address.
- A byte at a halfword-aligned address is the most significant byte in the halfword at that address.

See also [Little-endian](#) and [Endianness](#).

Boundary scan chain

A boundary scan chain is made up of serially-connected devices that implement boundary scan technology using a standard JTAG TAP interface. Each device contains at least one TAP controller containing shift registers that form the chain connected between **TDI** and **TDO**, through which test data is shifted. A core can contain several shift registers, enabling a scan to access selected parts of the device.

Burst

A group of transfers that form a single transaction. With AMBA protocols, only the first transfer of the burst includes address information, and the transfer type determines the addresses used for subsequent transfers.

Cold reset

A cold reset has the same effect as starting the processor by turning the power on. This clears main memory and many internal settings. Some program failures can lock up the core and require a cold reset to restart the system.

This is also known as power-on or powerup reset.

See also [Processing Element \(PE\)](#), [Warm reset](#).

Completer

An agent in a computing system that responds to and completes a memory transaction that was initiated by a Requester.

See also [Requester](#).

Core reset

See [Warm reset](#).

DAP

See [Debug Access Port \(DAP\)](#).

Data Link layer

The layer of an ADI implementation that provides the functional and procedural means to transfer data between the external debugger and the *Debug Port* (DP). ADIv5 and upwards define two Data Link layers, one based on the IEEE 1149.1 Standard Test Access Port and Boundary Scan Architecture, referred to as JTAG, and one based on the Arm Serial Wire Debug protocol interface, referred to as SW-DP.

DATA LINK DEFINED

Means that the behavior is not defined by the base architecture, but must be defined and documented by individual Data Link layers of the architecture.

When DATA LINK DEFINED appears in body text, it is always in SMALL CAPITALS.

DBGTAP

See [Debug Test Access Port \(DBGTAP\)](#).

Debug Access Port (DAP)

A block that acts as an AMBA, AHB, or AHB-Lite Requester on a system bus, to provide access to the debug target.

Debug Test Access Port (DBGTAP)

A debug control and data interface based on IEEE 1149.1 JTAG Test Access Port (TAP).

Debugger	A debugging system that includes a program, used to detect, locate, and correct software faults, together with custom hardware that supports software debugging.
Doubleword	A 64-bit data item. Doublewords are normally at least word-aligned in Arm systems.
Doubleword-aligned	A data item having a memory address that is divisible by eight.
Embedded Trace Macrocell (ETM)	A hardware macrocell that, when connected to a core, outputs trace information on a trace port. The ETM provides core-driven trace through a trace port compliant to the ATB protocol. An ETM always supports instruction trace, and might support data trace.
Endianness	The scheme that determines the order of the successive bytes of data in a larger data structure when that structure is stored in memory. <i>See also</i> Little-endian and Big-endian .
ETM	<i>See</i> Embedded Trace Macrocell (ETM) .
Halfword	A 16-bit data item. Halfwords are normally halfword-aligned in Arm systems.
Halfword-aligned	A data item having a memory address that is divisible by 2.
Host	A computer that provides data and other services to another computer. In the context of an Arm debugger, a computer providing debugging services to a target being debugged.
IMP DEF	<i>See</i> IMPLEMENTATION DEFINED .
IMPLEMENTATION DEFINED	Behavior that is not defined by the architecture, but must be defined and documented by individual implementations. When IMPLEMENTATION DEFINED appears in body text, it is always in SMALL CAPITALS.
Joint Test Action Group (JTAG)	An IEEE group focused on silicon chip testing methods. Many debug and programming tools use a Joint Test Action Group (JTAG) interface port to communicate with processors. <i>See</i> IEEE Std 1149.1-1990 IEEE Standard Test Access Port and Boundary-Scan Architecture specification available from the IEEE Standards Association.
JTAG	<i>See</i> Joint Test Action Group (JTAG) .
JTAG Access Port (JTAG-AP)	An optional component of the DAP that provides debugger access to on-chip scan chains.
JTAG Debug Port (JTAG-DP)	An optional external interface for the DAP that provides a standard JTAG interface for debug access.
JTAG-AP	<i>See</i> JTAG Access Port (JTAG-AP) .
JTAG-DP	<i>See</i> JTAG Debug Port (JTAG-DP) .
Little-endian	In the context of the Arm architecture, little-endian is defined as the memory organization in which the most significant byte of a word is at a higher address than the least significant byte. <i>See also</i> Big-endian and Endianness .
PE	<i>See</i> Processing Element (PE) .
Powerup reset	<i>See</i> Cold reset .
Processing Element (PE)	The abstract machine defined in the Arm architecture, as documented in an <i>Arm® Architecture Reference Manual</i> . A PE implementation that is compliant with the Arm architecture must conform with the behaviors described in the corresponding <i>Arm® Architecture Reference Manual</i> .

RAO See [Read-As-One \(RAO\)](#).

RAO/WI Read-as-One, Writes Ignored.

Hardware must implement the field as Read-as-One, and must ignore writes to the field. Software can rely on the field reading as all 1s, and on writes being ignored. This description can apply to a single bit that reads as 0b1, or to a field that reads as all 1s.

See also [Read-As-One \(RAO\)](#).

RAZ See [Read-As-Zero \(RAZ\)](#).

RAZ/WI Read-as-Zero, Writes ignored.

Hardware must implement the field as Read-as-Zero, and must ignore writes to the field. Software can rely on the field reading as all 0s, and all writes being ignored. This description can apply to a single bit that reads as 0b0, or to a field that reads as all 0s.

See also [Read-As-Zero \(RAZ\)](#).

Read-As-One (RAO)

Hardware must implement the field as reading as all 1s. Software can rely on the field reading as all 1s. This description can apply to a single bit that reads as 0b1, or to a field that reads as all 1s.

Read-As-Zero (RAZ)

Hardware must implement the field as reading as all 0s. Software can rely on the field reading as all 0s. This description can apply to a single bit that reads as 0b0, or to a field that reads as all 0s.

Requester

An agent in a computing system that is capable of initiating memory transactions.

See also [Completer](#).

RES0

A reserved bit or field with [Should-Be-Zero-or-Preserved \(SBZP\)](#) behavior. Used for fields in register descriptions, and for fields in architecturally-defined data structures that are held in memory, for example in translation table descriptors.

———— **Note** —————

RES0 is not used in descriptions of instruction encodings.

Within the architecture, there are some cases where a register bit or bitfield:

- Is RES0 in some defined architectural context.
- Has different defined behavior in a different architectural context.

This means the definition of RES0 for register fields is:

If a bit is RES0 in all contexts

It is IMPLEMENTATION DEFINED whether:

1. The bit is hardwired to 0b0. In this case:
 - Reads of the bit always return 0b0.
 - Writes to the bit are ignored.

The bit might be described as RES0, WI, to distinguish it from a bit that behaves as described in 2.

2. The bit can be written. In this case:
 - An indirect write to the register sets the bit to 0b0.
 - A read of the bit returns the last value successfully written to the bit.

———— **Note** —————

As indicated in this list, this value might be written by an indirect write to the register.

If the bit has not been successfully written since reset, then the read of the bit returns the reset value if there is one, or otherwise returns an UNKNOWN value.

- A direct write to the bit must update a storage location associated with the bit.
- The value of the bit must have no effect on the operation of the core, other than determining the value read back from the bit.

Whether RES0 bits or fields follow behavior 1 or behavior 2 is implementation defined on a field-by-field basis.

If a bit is RES0 only in some contexts

When the bit is described as RES0:

- An indirect write to the register sets the bit to 0b0.
- A read of the bit must return the value last successfully written to the bit, regardless of the use of the register when the bit was written.

———— Note ————

As indicated in this list, this value might be written by an indirect write to the register.

If the bit has not been successfully written since reset, then the read of the bit returns the reset value if there is one, or otherwise returns an unknown value.

- A direct write to the bit must update a storage location associated with the bit.
- While the use of the register is such that the bit is described as RES0, the value of the bit must have no effect on the operation of the core, other than determining the value read back from that bit.

For any RES0 bit, software:

- Must not rely on the bit reading as 0b0.
- Must use an *SBZP* policy to write to the bit.

The RES0 description can apply to bits or bitfields that are read-only, or are write-only:

- For a read-only bit, RES0 indicates that the bit reads as 0b0, but software must treat the bit as UNKNOWN.
- For a write-only bit, RES0 indicates that software must treat the bit as *SBZ*.

This RES0 description can apply to a single bit that should be written as its preserved value or as 0b0, or to a field that should be written as its preserved value or as all 0s.

In body text, the term RES0 is shown in SMALL CAPITALS.

See also *Read-As-Zero (RAZ)*, *Should-Be-Zero-or-Preserved (SBZP)*, *UNKNOWN*.

RES1

A reserved bit or field with *Should-Be-One-or-Preserved (SBOP)* behavior. Used for fields in register descriptions, and for fields in architecturally-defined data structures that are held in memory, for example in translation table descriptors.

———— Note ————

RES1 is not used in descriptions of instruction encodings.

Within the architecture, there are some cases where a register bit or bitfield:

- Is RES1 in some defined architectural context.
- Has different defined behavior in a different architectural context.

This means the definition of RES1 for register fields is:

If a bit is RES1 in all contexts

It is IMPLEMENTATION DEFINED whether:

1. The bit is hardwired to 0b1. In this case:
 - Reads of the bit always return 0b1.
 - Writes to the bit are ignored.

The bit might be described as RES1, WI, to distinguish it from a bit that behaves as described in 2.
2. The bit can be written. In this case:
 - An indirect write to the register sets the bit to 0b1.
 - A read of the bit returns the last value successfully written to the bit.

———— **Note** ————

As indicated in this list, this value might be written by an indirect write to the register.

If the bit has not been successfully written since reset, then the read of the bit returns the reset value if there is one, or otherwise returns an UNKNOWN value.

- A direct write to the bit must update a storage location associated with the bit.
- The value of the bit must have no effect on the operation of the core, other than determining the value read back from the bit.

Whether RES1 bits or fields follow behavior 1 or behavior 2 is implementation defined on a field-by-field basis.

If a bit is RES1 only in some contexts

When the bit is described as RES1:

- An indirect write to the register sets the bit to 0b1.
- A read of the bit must return the value last successfully written to the bit, regardless of the use of the register when the bit was written.

———— **Note** ————

As indicated in this list, this value might be written by an indirect write to the register.

If the bit has not been successfully written since reset, then the read of the bit returns the reset value if there is one, or otherwise returns an unknown value.

- A direct write to the bit must update a storage location associated with the bit.
- While the use of the register is such that the bit is described as RES1, the value of the bit must have no effect on the operation of the core, other than determining the value read back from that bit.

For any RES1 bit, software:

- Must not rely on the bit reading as 0b1.
- Must use an *SBOP* policy to write to the bit.

The RES1 description can apply to bits or bitfields that are read-only, or are write-only:

- For a read-only bit, RES1 indicates that the bit reads as 0b1, but software must treat the bit as UNKNOWN.
- For a write-only bit, RES1 indicates that software must treat the bit as *SBO*.

This RES1 description can apply to a single bit that should be written as its preserved value or as 0b0, or to a field that should be written as its preserved value or as all 1s.

In body text, the term RES1 is shown in SMALL CAPITALS.

See also *Read-As-One (RAO)*, *Should-Be-One-or-Preserved (SBOP)*, *UNKNOWN*.

Reserved

Unless otherwise stated in the architecture or product documentation:

- Reserved instruction and 32-bit system control register encodings are unpredictable.

- Reserved 64-bit system control register encodings are undefined.
- Reserved register bit fields are UNK/SBZP.

SBO See [Should-Be-One \(SBO\)](#).

SBOP See [Should-Be-One-or-Preserved \(SBOP\)](#).

SBZ See [Should-Be-Zero \(SBZ\)](#).

SBZP See [Should-Be-Zero-or-Preserved \(SBZP\)](#).

Scan chain A scan chain is made up of serially-connected devices that implement boundary scan technology using a standard JTAG TAP interface. Each device contains at least one TAP controller containing shift registers that form the chain connected between **TDI** and **TDO**, through which test data is shifted. Processors can contain several shift registers to enable you to access selected parts of the device.

Serial Wire debug (SWD)

A debug implementation that uses a serial connection between the SoC and a debugger. This connection normally requires a bidirectional data signal and a separate clock signal, rather than the four to six signals required for a JTAG connection.

Serial-Wire Debug Port (SW-DP)

The interface for Serial Wire Debug.

Serial Wire JTAG Debug Port (SWJ-DP)

The SWJ-DP is a combined JTAG-DP and SW-DP that you can use to connect either a Serial Wire Debug (SWD) or JTAG probe to a target.

Should-Be-One (SBO)

Hardware must ignore writes to the field.

Software should write the field as all 1s. If software writes a value that is not all 1s, it must expect an UNPREDICTABLE result.

This description can apply to a single bit that should be written as 0b1, or to a field that should be written as all 1s.

Should-Be-One-or-Preserved (SBOP)

The Armv7 Large Physical Address Extension modified the definition of SBOP to apply to register fields that are SBOP in some but not all contexts. From the introduction of Armv8 such register fields are described as RES1, see [RES1](#). The definition of SBOP given here applies only to fields that are SBOP in all contexts.

Hardware must ignore writes to the field.

If software has read the field since the core implementing the field was last reset and initialized, it should preserve the value of the field by writing the value that it previously read from the field. Otherwise, it should write the field as all 1s.

If software writes a value to the field that is not a value previously read for the field and is not all 1s, it must expect an UNPREDICTABLE result.

This description can apply to a single bit that should be written as its preserved value or as 0b1, or to a field that should be written as its preserved value or as all 1s.

See also [Should-Be-Zero-or-Preserved \(SBZP\)](#), [Should-Be-One \(SBO\)](#).

Should-Be-Zero (SBZ)

Hardware must ignore writes to the field.

Software should write the field as all 0s. If software writes a value that is not all 0s, it must expect an UNPREDICTABLE result.

This description can apply to a single bit that should be written as 0b0, or to a field that should be written as all 0s.

Should-Be-Zero-or-Preserved (SBZP)

The Armv7 Large Physical Address Extension modified the definition of SBZP to apply to register fields that are SBZP in some but not all contexts. From the introduction of Armv8 such register fields are described as res0, see [RES0](#). The definition of SBZP given here applies only to field that are SBZP in all contexts.

Hardware must ignore writes to the field.

If software has read the field since the core implementing the field was last reset and initialized, it must preserve the value of the field by writing the value that it previously read from the field. Otherwise, it must write the field as all 0s.

If software writes a value to the field that is not a value previously read for the field and is not all 0s, it must expect an UNPREDICTABLE result.

This description can apply to a single bit that should be written as its preserved value or as 0b0, or to a field that should be written as its preserved value or as all 0s.

See also [Should-Be-One-or-Preserved \(SBOP\)](#), [Should-Be-Zero \(SBZ\)](#).

SWD *See* [Serial Wire debug \(SWD\)](#).

SW-DP *See* [Serial-Wire Debug Port \(SW-DP\)](#).

SWJ-DP *See* [Serial Wire JTAG Debug Port \(SWJ-DP\)](#)

TAP *See* [Test Access Port \(TAP\)](#).

Test Access Port (TAP)

The collection of four mandatory and one optional terminals that form the input/output and control interface to a JTAG boundary-scan architecture. The mandatory terminals are **TDI**, **TDO**, **TMS**, and **TCK**. In the JTAG standard, the **nTRST** signal is optional, but this signal is mandatory in Arm processors because it is used to reset the debug logic.

See also [Joint Test Action Group \(JTAG\)](#), [Debug Test Access Port \(DBGTAP\)](#).

Trace port A port on a device, such as a processor or ASIC, to output trace information.

Unaligned An unaligned access is an access where the address of the access is not aligned to the size of the elements of the access.

See also [Aligned](#).

UNKNOWN An UNKNOWN value does not contain valid data, and can vary from moment to moment, instruction to instruction, and implementation to implementation. An UNKNOWN value must not return information that cannot be accessed at the current or a lower level of privilege using instructions that are not UNPREDICTABLE or CONSTRAINED UNPREDICTABLE and do not return UNKNOWN values.

An UNKNOWN value must not be documented or promoted as having a defined value or effect.

When UNKNOWN appears in body text, it is always in SMALL CAPITALS.

UNP *See* [UNPREDICTABLE](#).

UNPREDICTABLE

For an Arm processor, UNPREDICTABLE means the behavior cannot be relied upon. UNPREDICTABLE behavior must not perform any function that cannot be performed at the current or a lower level of privilege using instructions that are not UNPREDICTABLE.

UNPREDICTABLE behavior must not be documented or promoted as having a defined effect. An instruction that is UNPREDICTABLE can be implemented as UNDEFINED.

In an implementation that supports Virtualization, the Non-secure execution of unpredictable instructions at a lower level of privilege can be trapped to the hypervisor, provided that at least one instruction that is not unpredictable can be trapped to the hypervisor if executed at that lower level of privilege.

For an Arm trace macrocell, UNPREDICTABLE means that the behavior of the macrocell cannot be relied on. Such conditions have not been validated. When applied to the programming of an event resource, only the output of that event resource is UNPREDICTABLE. UNPREDICTABLE behavior can affect the behavior of the entire system, because the trace macrocell can cause the core to enter Debug state, and external outputs can be used for other purposes.

Note

In issue A of this document, UNPREDICTABLE also meant an UNKNOWN value.

When UNPREDICTABLE appears in body text, it is always in SMALL CAPITALS.

W1C

Hardware must implement the bit as follows:

- Writing a 0b1 to the bit clears the bit to 0b0.
- Writing a 0b0 to the bit has no effect.

Warm reset

Also known as a core reset. Initializes most of the processor functionality, excluding the debug controller and debug logic. This type of reset is useful if you are using the debugging features of a processor.

See also [Cold reset](#).

WI

Hardware must ignore writes to the field. Software can rely on writes being ignored. This description can apply to a single bit, or to a field.

Word

A 32-bit data item. Words are normally word-aligned in Arm systems.

Word-aligned

A data item having a memory address that is divisible by four.

